

**MAY  
2009**

Volume 36

Issue 5

[www.eaa43.com](http://www.eaa43.com)



**EAA MILE HIGH CHAPTER 43**

*Founded May 1958*

## **MILE HIGH FLYER**

### **Cessna Aircraft Company**



Clyde Vernon Cessna was born in Iowa in 1879 and grew up on a Kansas farm. He had a fifth grade education, worked on the family farm, became a car mechanic and later a car salesman. He became captivated with flying after learning of Louis Bieriot's flight across the English Channel. He purchased a monoplane for himself and spent the next several years traveling to air shows. He spent a month at the Queen Airplane Company, learning the fundamentals of flight and the art of plane building. He then spent his life savings of \$7,500 to buy an exact copy of the Bieriot X1 monoplane, in kit form, and shipped it west to his home in Enid, OK. After finishing the plane, he taught himself to fly. After 14 crashes, he made a successful flight. He was nicknamed the "Birdman of Enid." In 1924, Clyde partnered with fellow aviation pioneers, Lloyd C. Stearman and Walter H. Beech to form the Travel Air Manufacturing Co., a biplane manufacturing firm in Wichita Kansas. Clyde became its president. Still with a passion for monoplanes, in 1927, he left the company to form his own, the Cessna Aircraft Company. The Phantom was the first plane. During the Great Depression, Clyde and his son Eldon turned their attention to building racing aircraft. Their CR-1 made a good showing in the 1932 Air Races. But Clyde abruptly retired from aviation when his close friend, Roy Liggett, was killed in the crash of a Cessna-built racing plane. He never again participated actively in the industry.

#### **EDITOR**

**Bob Young**

**Home:**

**303-466-6902**

**Cell:**

**303-921-4423**

**E-Mail:**

**Bobapilot**

**@aol.com**

Story by pilotfriend, picture below is the Phantom from Cessna History and picture right from wings over Kansas



*Pilot Roy Liggett rests against the Cessna CR-2 racer, in which he was killed in 1933. Liggett's death sapped Clyde*

**Next Chapter 43 meeting will be our annual picnic and fly-in at Bob Wilson's hanger at Vance Brand Airport on May 9th. Eat at Noon.**



## EAA 43 BOARD MEETING April 11, 2009

Members present: *Greg Hall, Brian Cabebe, Bob Young, Steve Beach, Gene Horsman, Dave Bieseimeier, Bill & Mary Mitchell, Roxie Juul, Bruce Handley, John Reuterskiold, and Roger Standard.*

*Greg* called the meeting to order. The first on the agenda was a Long EZ project that was offered to the chapter as a donation. *Brian* brought up the issue of liability insurance for the project. Suggestions for the plane were; sell for a fund raiser, use as a learning project, raffle it or hold an auction. The board voted to accept the aircraft and decide what to do with it later.

**Snowbusters setup:** Friday would be to haul in the tables, chairs and tents. A generator would be used for the coffeepots. Foul weather date was set for the following Saturday, April 25.

**Chapter website:** *Bruce* shared about our website came about and how it was difficult making changes on it. He told us how to submit information and how long it would take to put it on the site.

It was mentioned that *Ann Cochran* had some surgery. The board and membership wishes her a speedy recovery.

Program discussion on combining our chapter and the 99's chapter for a program. The program would be *Carol Garret* on her round the world trip in her Mooney, Feb to Oct in 2003. It could be scheduled at our annual pizza party. The topic was tabled until some contacts could be made.

The chapter's picnic will be held at *Bob Wilson's* hanger at Vance Brand Airport again this year. We would need about 4 tables and 2 grills. (existing ones were lost in a wind storm). A flyer will be sent out with a map, details and directions.

A Chapter 43 patch will be sent to EAA for the Founder's Wing.

Meeting adjourned.

## Minutes of EAA Chapter 43 April 11, 2009

*Greg Hall*, President, called the meeting to order at 7:03.

Minutes of the March meeting were approved.

Guests: *Jason Gore* of Boulder, *Tony Cochran* of Broomfield (Deans' son), *Glenn and Linda Sneed* of Northglenn. Welcome.

**Treasurer's Report:** The chapter is very prosperous. Details given at meetings.

**Safety Report:** *Bill Mitchell* mentioned that there are many fly-ins going on. Be safe and enjoy them.

*Stan Specht* mentioned that the pilot and passenger of the Zenith 801 that crashed are recovering well.

*Bill* also mentioned was a Lancair that landed short of the runway at Vance Brand Airport in Longmont on 1/30/2009 with substantial damage. The unlatched canopy opened during takeoff and the plane became hard to control.



## Minutes Continued

**Trip Reports:** *Bill Mitchell* drove up to Casper in a blizzard to test fly a RV-7. After staying overnight, the next day was clear and the plane passed the test flight.

*Stan Specht* flew to Arizona and encountered some high winds on return. One nice accomplishment of *Stan* and his Kitfox is they have flown in 49 states and every public airport in Colorado.

*Progress Reports:* None given.

**Old Business:** Final preparations for the event were made.

**New Business:** *Ernest Hawkins* has offered to donate his Long EZ project to the chapter if it doesn't sell on Barnstormers.

*Bob Wilson* gave some details about the annual picnic at his hanger. Some grills, tables, 4 cooks will be needed. A flyer and directions will be sent out.

*Brian Cabebe* reported the next Young Eagles event will be at Erie Days.

*Steve Beach* asked those members that were going to AirVenture to help out at the rib building booth at KidVenture.

*Gene Horsman* read several letters about some initiatives that are being taken by the Transportation Security Administration (TSA). The issues are sketchy at best. The results would be any airport served by commercial traffic would have anyone with airport access to have a background check. Each airport would have their own security badge. Pilots without badges would be escorted by airport personal. Some discussion followed about how to voice our option about our concerns. The directive is 1542-04-08F.

Link to read the 14-page directive.

<http://www.docstoc.com/docs/5345788/US-TSA-Security-Directive-Establishing-A-New-Aviation-ID-Card-Scheme-1542-04-08F-10-Dec-2008>. Note: Congressmen links later in newsletter.

*Bill Mitchell* mentioned the spaghetti lunch at Platte Valley Airport.

*Greg Hall* announced the Ice cream social at Sun-N-Fun.

*Dean Cochran* motioned the meeting be adjourned at 7:52.

Program by Georg Grell. As an employee of N.O.A.A. as a meteorologist, Georg traveled around Alaska in a Super Cub. As a result, he presented a great program of the trip with pictures and videos. Thanks, Georg.





**EAA 43 ANNUAL PICNIC  
MAY 9 AT BOB WILSON'S HANGER  
AT VANCE BRAND AIRPORT,  
LONGMONT**

**COME AT 11:00 TO HELP SET UP,  
COOK, OR JUST VISIT. PLANES AND  
CARS WELCOME.  
EAT AT NOON.**

**POT LUCK PICNIC** - bring your favorite entrée, salad, or desert! Don't forget serving spoons & spatulas. Burgers & hot dogs furnished. If you want steak, chicken, etc., bring your own. You might want to bring along these directions so you don't get lost!

**DIRECTIONS TO THE CHAPTER 43 PICNIC.  
LONGMONT AIRPORT 2V2 SAT, MAY 9 th**

The airport is on the far WEST side of Longmont. Picnic site is HANGAR # 70, last row to the WEST, NORTH side of runway. CAR parking is west, around behind the hangar row.

AIRPLANE parking is on both sides of taxiway, smoothest is on the west. East side has one to two inch drop-off. We will have helpers for parking, bring tie-downs if you want. Overflow parking is on the ramp to the east.

DRIVING? From I-25-exit 240, HWY 119 West to Longmont. There is a new by-pass that puts you on Ken Pratt Blvd at HWY 287, the other route in, continue West on Ken Pratt Blvd for 7/10 mile, at the Railroad tracks, jog right onto NELSON ROAD, continue West 1.7 miles to AIRPORT ROAD, turn right at the light onto Airport Road. The airport is 6/10 mile on the left, lots of construction - be careful, DON'T go in the main entrance, go past a little ways to ST. VRAIN ROAD.

**Big sign says, CITY OF LONGMONT, Public Works.** Go West 2/10 mile, where road jogs to the right, **you jog to the left** into the Airport and follow the blacktop around to the last row of hangars and go around behind.

If coming from the NORTH, 17th Ave is a good through street west to Airport Rd.

**If LOST call Bob Wilson's cell phone: 303-775-9732**





### The Parrot On The Plane!

On reaching his plane seat a man is surprised to see a parrot strapped in next to him. He asks the stewardess for a coffee where upon the parrot squawks "and get me a whisky you chicken!" the stewardess, flustered, brings back a whisky for the parrot and forgets the coffee.

When this omission is pointed out to her the parrot drains its glass and bawls "and get me another whisky you turkey". Quite upset, the girl comes back shaking with another whisky but still no coffee.

Unaccustomed to such slackness the man tries the parrot's approach "I've asked you twice for a coffee, go and get it now or I'll give you a slap".

Next moment both he and the parrot have been wrenched up and thrown out of the emergency exit by two burly stewards. Plunging downwards the parrot turns to him and says "For someone who can't fly you complain too much!"

*Author Unknown*

For those in Colorado who wish to contact their Congressmen about recent TSA activity.

Senator Mark Udall	<a href="http://markudall.senate.gov">http://markudall.senate.gov</a>
Senator Michael Bennet	<a href="http://bennet.senate.gov/public/">http://bennet.senate.gov/public/</a>
Rep. Diana DeGette	<a href="http://degette.house.gov/">http://degette.house.gov/</a>
Rep. Jared Polis	<a href="http://polis.house.gov/">http://polis.house.gov/</a>
Rep. John Salazar	<a href="http://www.house.gov/salazar/">http://www.house.gov/salazar/</a>
Rep. Betsy Markley	<a href="http://betsymarkly.house.gov/">http://betsymarkly.house.gov/</a>
Rep. Doug Lamborn	<a href="http://lamborn.house.gov/">http://lamborn.house.gov/</a>
Rep. Mike Coffman	<a href="http://Coffman.house.gov/">http://Coffman.house.gov/</a>

## FOR SALE

Roger Standard is selling his 1/4 share of this RV-6A N167CS w/ O-360 hangered at Vance Brand in Longmont. Contact: [n5773a@hotmail.com](mailto:n5773a@hotmail.com)



## FOR RENT

### HANGER AVAILABLE FOR RENT

ON THE WEST SIDE OF  
ERIE AIRPORT (EIK)

\$250 PER MONTH

CONTACT

Jeff Cain

at [biplane@ix.netcom.com](mailto:biplane@ix.netcom.com)

303-722-4311

OR

Bill Mitchell

At [billyav8r@yahoo.com](mailto:billyav8r@yahoo.com)

303-722-4311



# KitTips

## Make your own tailwheel— from a hockey puck.

BY JIM LOYD

**A** hockey puck is made from very hard rubber so it can take a lot of weight and abuse. It's cheap! The puck costs about a buck and most of the other parts are hardware store items or are lying around the shop.

The drawings pretty much cover everything.

Drill the axle hole  $\frac{1}{16}$ -inch smaller in diameter than the bushing you use. Chamfer one end of the bushing (brass, copper or soft steel) a little bit and drive it through the hole. A tight fit helps keep the puck from rotating on the bushing.

Five different axle configurations are presented:

Number 1 is adequate for ultralights. The floating hub washers and necessary sideplay between wheel hub and yoke

allow more flexing of the rubber puck on the axle under sideloads.

Numbers 2 and 3 are for ARVs and single-place aircraft with light tail weights. Their hubs resist flexing at the axle and therefore help the wheel withstand side loads.

Numbers 4 and 5 are adequate for two-place planes with normal tailwheel weights. Use 8-32 bolts (or nuts and bolts) to clamp hubs on number 4.

Number 5 has more ground contact and better flotation for heavier-tailed planes. The axle is enlarged to  $\frac{1}{8}$ -inch. The hub washers are larger ( $1\frac{1}{4}$  to  $1\frac{1}{2}$ -inch) than those on number 4. Use 10-32 bolts (or nuts and bolts) to clamp hubs.

Bevel the edges of the puck to reduce nicks and gouges. □

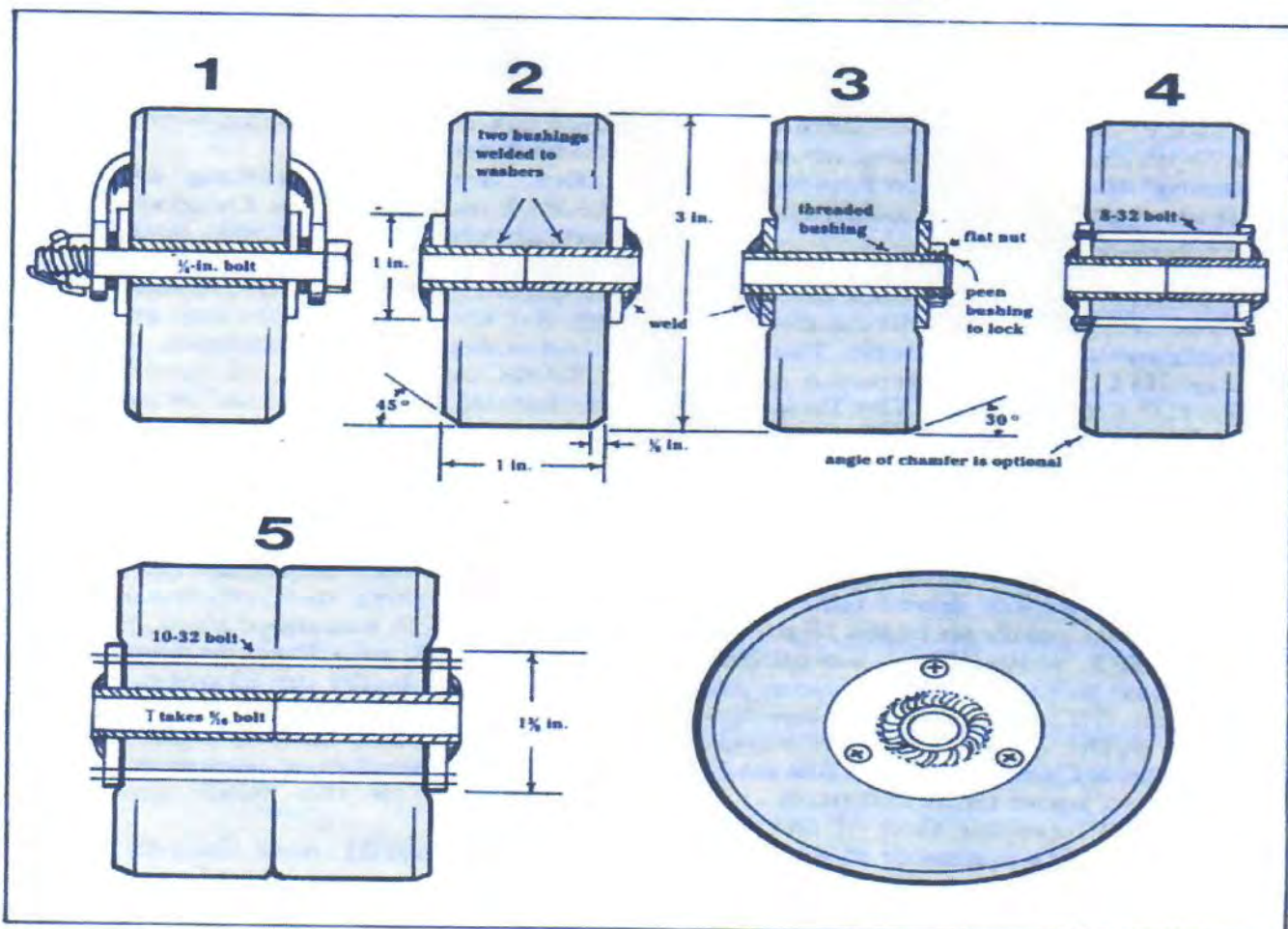



### FLY-INS, DRIVE-INS, PANCAKE BREAKFASTS, AVIAVIATION EVEN

- ◆ May 10 Mother's Day
- ◆ May 14-16 Parade of Planes Olathe KS [K1XD](#) [paradeofplanes.com](#)
- ◆ May 16 Armed Forces Day
- ◆ May 16 Erie CO Days Young Eagle Rides [EIK](#)
- ◆ May 16-17 Fly-In Platte Valley Airpark [18V](#) WW1 & WW2 planes  
[lafayettefoundation.comcast.org](#)
- ◆ May 27 USAF Thunderbirds at Air Force Academy
- ◆ May 29-31 Fly-In to Oklahoma Tinker AFB [OUN](#) 303-288-7371
- ◆ June 3-9 EAA B-17 CO Tour Stop at Centennial Airport [APA](#) Hosted by  
Wings Over the Rockies museum. [www.B17.org](#) w/Young Eagle Rides
- ◆ June 4-6 Biplane Expo Frank Phillips Field, Bartlesville, OK [biplaneexpo.com](#) [BVO](#)
- ◆ June 10 International Young Eagles Day
- ◆ June 13-14 Stearman Fly-In St. Francis KS [SYF](#) [www.stearmanflyin.org](#)
- ◆ June 13-14 Front Range Airport Air Show *Blue Angels* [FTG](#) [www.ftg-airport.com](#)
- ◆ June 14 Flag Day
- ◆ June 20 Boulder Airport Day 9-3 Young Eagle Rides [1V5](#) 303-441-3108
- ◆ June 20 JAA Rocky Mtn. Metro Airport fly-in & car show [BJC](#) [cq7014@aol.com](#)
- ◆ June 21 Father's Day
- ◆ June 21 Summer Begins
- ◆ June 23-26 99'S Air Race Classic Englewood CO [APA](#) to Atlantic IA [AIO](#) [colorado99s.org](#)
- ◆ June 27 Kelly Air Park Elbert CO fly-in breakfast 7-11 [C015](#) [kellyairpark.com](#)
- ◆ July 4 Craig CO Airfest breakfast, fly overs, [CAG](#) [rdlegal@bresnan.net](#)
- ◆ July 11 33rd Annual Denver to Jackpot NV [BJC](#) to [06U](#) 528sm [eriehaglin@aol.com](#)
- ◆ July 11 EAA 1267 fly-In breakfast in Kremmling CO [20V](#) [www.eaa1267.org](#)
- ◆ July 27/Aug2 Airventure Oshkosh somewhere in Wisconsin [OSH](#) [eaa.org](#)
- ◆ Aug 22-23 Rocky Mountain Regional Fly-In and Air Show [BJC](#) [rmrfi.org](#)
- ◆ Aug 29 Vance Brand Airport Open House Longmont [LMO](#) [wwwci,longmont.co.us/airport](#)
- ◆ Sept 12 Radial Engine Expo at Akron Co [AKO](#) [admin@nationalradialengineexhibition.com](#)
- ◆ Sept 19 EAA 43 Builders Forum Location TBA

#### INCREASE YOUR BUSINESS

#### ADVERTISE IN OUR NEWSLETTER

**RATES ARE \$10 PER MONTH OR \$100 PER YEAR FOR A BUSINESS CARD SIZE.**

**WE REACH 50 AIRPORTS IN 7 STATES**

**E-MAIL THE EDITOR FOR DETAILS**

### TheNPlace.com Custom Aviation Embroidery



Send us a picture of your plane, we'll digitize it & embroider on caps, shirts, etc.

*Your airplane, not a generic image!*  
[www.TheNPlace.com](#)

#### Support Your Local FBO

Vector FBO and Flight Training. Jason Hurd runs a first class business at Erie Airport.  
Contact him at 303-664-0633 or [www.vectorair.net](#)



# EAA Mile High Chapter 43

## Chapter Officers

President	Greg Hall	303-424-4216
Vice President	Brian Cabebe	303-748-5570
Vice President	Kyle Heckman	303-666-6485
Secretary	Bob Young	303-466-6902
Treasurer	Lynn Miller	303-666-8233

## Volunteer Officers

Technical Counselor	Bob Green	303-659-5829
Technical Counselor	Dave Biese-meier	720-480-5826
Technical Counselor	Pat Claar	303-940-3530
Technical Counselor	Art Schwarz	303-421-2930
Flight Advisor	Bill Mitchell	303-427-4025
Newsletter Editor	Bob Young	303-466-6902
Young Eagles Coord	Brian Cabebe	303-748-5570
Member Data Base Ed.	John Reuterskiold	303-659-2773
Web Master	Bruce Handley	303-494-5412
Safety Officer	Bill Mitchell	303-427-4025
Refreshments	John & Roxie Juul	303-466-2600
Audio / Visual	Herrill Davenport	303-460-7789

Disclaimer: Be aware that as always, in past, present, and future, any communications issued by Experimental Aircraft Association Chapter 43, regardless of format, and/or media used, which includes, but is not limited to, this newsletter and audio/visual recordings, is presented only in the context of a clearing house of ideas, opinion, and personal experience accounts. Anyone using ideas, opinions, information, etc., does so at their own risk. Therefore, no liability is expressed or implied by the Experimental Aircraft Association Chapter 43, or any of its members. Any event announced and/or listed herein, except as noted, is done as a matter of information and does not constitute approval, sponsorship, control, or endorsement of said event.

This newsletter is published by Chapter 43 of the Experimental Aircraft Association for the use, education, and enjoyment of the members and others to whom it is provided. No claim is made for technical accuracy of material presented. Editorial content is the opinion of the contributor and does not reflect the position of Chapter 43 or the Experimental Aircraft Association. Submission of articles, comments, or inquiries for publication in the newsletter are encouraged. Meetings are normally held on the second Saturday of each month at 7:00 P.M. The place is determined each month.

## Mile High Flyer

EAA Mile High Chapter 43

John Reuterskiold

Data Base Editor

32651 E. 149th. Avenue

Brighton, CO 80603

FIRST CLASS



Next Chapter 43 meeting will be our annual picnic and fly-in at Bob Wilson's hanger at Vance Brand Airport on May 9th. Eat at Noon.