



THE LIPPISCH LETTER

Experimental Aviation Association Chapter 33

January 2020

Iowa's Doug Rozendaal and "That's All...Brother"

by Minnetta Gardinier

Doug Rozendaal of Clear Lake IA joined us for our Fall social gathering and shared his story of piloting the C-47 *THAT'S ALL...BROTHER* to the commemorative events memorializing the 75th anniversary of D-Day. He learned to fly while at Iowa State University and has over 40 years of experience. Rozendaal is currently Chief of Staff for the Commemorative Air Force (CAF).

That's All...Brother flew in not only the D-Day operation but also Operation Market Garden in WWII and the Berlin Airlift (1948-49). Nearly 70 years later, this historical plane was found badly weathered and deteriorated in an aircraft graveyard in Oshkosh WI. Over the last three years, the CAF spent \$3 million over 22,000 hrs to restore this C-47 Skytrain to its original airworthiness and luster at Basler Turbo Conversions at OSH.

Following her first post-restoration flights in Wisconsin, *That's All...Brother* was flown to her new home in San Marcos TX with the Central TX Wing of the CAF. Final work details were completed restoring the plane to its June 1944 state.



In the boneyard...pre-restoration...

(Continued on page 3)



In This Issue

- Rozendaal & That's All Brother
- Upcoming EAA Webinars
- Justin's Favorite Podcasts
- Young Eagles
- Build - Sailer's RV-9A Flies!
- Long Cross-Country: Greenland
- EAA 33 Leadership
- EAA 33 Calendar
- Contact Us

www.eaa33.org

Upcoming EAA Webinars (Central time)			
1/29/20	7:00 pm	Compression Testing Aircraft Engines and Maximizing Cylinder Life <i>(qualifies for FAA WINGS & AMT credit)</i>	Bill Ross
2/5/20	7:00 pm	Bolted Joints in Tension <i>(qualifies for FAA WINGS & AMT credit)</i>	Mike Busch
2/11/20	7:00 pm	Tips & Tricks for Recording In-Flight Videos	Martin Pauly – Chapter 33
2/12/20	7:00 pm	Removing Winter Rust and Spin Avoidance <i>(qualifies for FAA WINGS credit)</i>	Gordon Penner
2/18/20	7:00 pm	EAA Flying Start: A Great Way to Grow Your Chapter	Serena Kamps (EAA HQ)
2/19/20	7:00 pm	Vans RV Maintenance Common Questions <i>(qualifies for FAA WINGS & AMT credit)</i>	Vic Syracuse
2/25/20	7:00 pm	Chapter Chat: Tax Exempt Basics	Patti Arthur (EAA HQ)
2/26/20	7:00 pm	Bang for the Buck: Affordable Aircraft Building	Tim Hoversten
3/4/20	7:00 pm	Bolted Joints in Shear <i>(qualifies for FAA WINGS & AMT credit)</i>	Mike Busch
3/11/20	7:00 pm	Stabilized Approaches and Go-Arounds <i>(qualifies for FAA WINGS credit)</i>	Prof. H. Paul Shuch
3/18/20	7:00 pm	ATC and You: Communicating With Confidence & Clarity <i>(qualifies for FAA WINGS credit)</i>	Richard Kennington & Bob Obma
4/22/20	7:00 pm	Flying Clubs - Growing Participation in Aviation	David Leiting (EAA HQ)
Registration is required, and space is limited.			
<i>EAA gratefully acknowledges the support of Aircraft Spruce & Specialty Co. for their generous sponsorship of EAA webinars.</i>			
https://www.eaa.org/eea/news-and-publications/eea-webinars			

Editor's Corner

by Minnetta Gardinier

We are now one month past the winter equinox. Our days are getting longer. Hooray!

As you are chilling this winter in the comfort of your home (or hangar), I hope that you enjoy the stories in this issue of your Lippisch Newsletter. You will find articles and photos submitted by your friends in our EAA Chapter.

Remember that this is YOUR newsletter with YOUR stories - new and old. Please share your aviation-related tales. Share your photos too. The more news that I receive from members, the richer your newsletter becomes, and the more we learn about each other.

Flight experiences (new and old)...build stories (past, present, and future)...flight instruction...flight lessons...airplane purchases/sales...aviation technology...hangar flying...flight safety. The sky is the limit! Please share!

And don't forget - a picture IS worth 1,000 words...plus or minus...simply share a photo and brief caption.

A few guidelines:

- **Copyright:** I cannot simply reprint non-EAA material from other publications. Provide the author's (or editor's) permission to republish their material. Or identify your source material for citation.
- **Photographs:** high resolution, print-quality files required. JPG files preferred - at least 300 dpi (dots per inch) resolution. E.g. - a 4x6 inch photo at 300 dpi is ~1 Mb file size. Use the HIGH quality setting on your camera or phone.
- **Articles:** submit text as DOC files for ease of transferring to the newsletter. Avoid PDF files due to extra time required to convert these files, and to avoid the artifacts that may get dragged along.

NEXT SUBMISSION DEADLINE - FEBRUARY 29, 2020

(Continued from page 1)

The flight crew made a shakedown flight from San Marcos TX to Dayton OH followed by positioning the plane in Goose Bay, Newfoundland (Canada) for final preparations for the flight to Europe. The en route stops included Narsarsauq (Greenland), Reykjavik (Iceland), Prestwick (Scotland), and Duxford (England). Of course, they made the flight using current navigation technology, but he emphasized the admiration that was due all of the WWII pilots when they made this crossing with no GPS - using the navigation technology of the 1940s.

Doug led the C-47 pilots at Duxford training them for a formation flight involving 800 planes in the U.K. He was quoted as saying "Flying formation is hard enough. Learning to do in a DC-3 is a whole other experience." Imagine a formation of 800 C-47s/DC-3s. A few days later on June 5th, about 25 C-47s crossed the English Channel with dozens of parachutists dropping from the planes as they crossed into Normandy.

He is passionate about that CAF's mission to keep this aviation history and the stories of these patriots alive. In his words, "We use these airplanes to tell the story and the lessons of World War II. Our mission is to honor educate and inspire."

Our Chapter much enjoyed the evening with Doug Rozendaal.

- Sources:
- Thomas Haines, AOPA, "That's All Brother" Leads the Pack Once Again (6/3/2019)
 - Jared McNett, Globe Gazette, Clear Lake Resident Piloting C-47 Into Normandy on D-Day (6/2/2019)
 - Richard Mallory Allnut, Warbird Digest, "That's All, Brother" Takes to the Skies!!! (1/31/2018)



Pilots Doug Rozendaal and Andy Maag at the controls.



Rozendaal & crew (photo credit: Jared McNett, Globe Gazette)



My Favorite Podcasts

by Justin Cook

What's a podcast? A podcast is a free, downloadable "talk show" with a defined topic. Each podcast also has a website, and you can "stream" (play) them from, if downloading them is not your cup of tea. "Smart" phones come with an application specifically for downloading and playing podcasts automatically.

There are countless different podcasts that cover various aviation topics – news, training, history, and just good old hangar talk. Podcasts vary in length and how often they are released. I have listed the ones that I listen to below with a short description:



The Green Dot (EAA): Released roughly every two weeks and is usually around one hour; features include AirVenture previews, guests from the museum speaker series, and Jack Pelton.



Uncontrolled Airspace: Releases are infrequent; features aviation news and hangar talk from various aviation writers.



Simple Flight: "A show about aviation which connects our listeners with the people and things that bring aviation to life!"



Aviation News Talk: "Podcast focuses on GA news, general tips for pilots, technical details on glass cockpits and flying GPS approaches, and an occasional interview. We also answer listener questions." 1-2 hrs, weekly



Opposing Bases: Two FAA Air Traffic Controllers answer questions and discuss ATC scenarios. Exceptionally produced with great content. 1-2 hrs, weekly



Airplane Geeks: "The weekly audio podcast that explores and expands your passion for aviation. Aviation news and interviews." Approx. 2 hrs



Never Again (AOPA): Pilots share first-person accounts of frightening experiences in the cockpit so that others can learn from their mistakes. Released infrequently.

There I was (AOPA): AOPA's Air Safety Institute invites you into the cockpit with pilots as they encounter unpredictable scenarios and fly safely out of them. Approx. 1 hr; released infrequently.

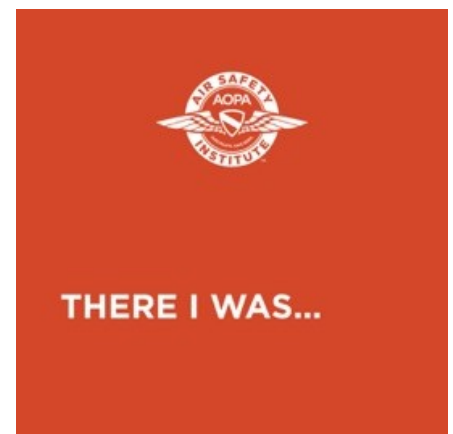

Pilot Requirements



People volunteer in EAA's Young Eagles program for a variety of reasons. Some see it as a chance to payback the kindness of those who inspired them to pursue flying. Others enjoy the opportunity to share their interest in aviation with young people. Many simply enjoy flying.

The most visible volunteers in the Young Eagles program are the pilots. More than 40,000 men and women worldwide have freely given of their time and talents to share the joy and excitement of aviation with young people.

Young Eagles Report

Total Young Eagles flown (since 1992): 2,199,356

Stats current as of 01/20/2020.

As we prepare for a new season of Young Eagle rallies and look for new YE pilots to participate in our events, let's review the EAA requirements.

You may already meet several of the requirements to fly a Young Eagle just by holding a current pilot certificate. Here are the requirements in full, which are designed to ensure your and your passenger's safety.

To fly passengers in the EAA Young Eagles program, you must:

- Be an EAA member.
- Complete the EAA Youth Protection Program, which includes a short training session and background check.
- Have a valid airman's certificate (sport pilot or greater).
- Possess a current medical certificate or BasicMed (if applicable).
- Be current to carry passengers in the aircraft you plan to use.
- Have a current biennial flight review.
- Conduct flights in an aircraft that is in airworthy condition.
- Have Aircraft Passenger Liability Insurance for the aircraft used (owned, rented, or borrowed).
- Adhere to all applicable Federal Aviation Regulations.
- Complete a Young Eagles registration form before the flight, signed by you and a parent or legal guardian.

Chapter 33 YE Coordinators - Connie White and John Anderson

2019 policy change: The pilot requirement of achieving 10 Young Eagle Flight before earning any Young Eagles credits was eliminated. ALL YE flights earn credits for their chapter of record. This may provide significant additional funding to a chapter to support its YE rallies.

2020 YOUNG EAGLE DATES

(details pending)

April	TBA	8:30 am - noon
Sat May 16	AWG	8:30 am - noon
Sat Jun 13*	CID?	8:30 am - noon
July	IOW	8:30 am - noon
August	TBA	8:30 am - noon
September	TBA	8:30 am - noon
October	TBA	8:30 am - noon

*** International Young Eagles Day**

Airports pending: C17, MXO, TZT, VTI, 8C4

It's a Bird! It's Denis' RV9A!

by Denis Sailer

I started building my RV9A from Vans Aircraft in July 2010 with the empennage kit, which was finished the following February. That kit consists of the horizontal stabilizer, vertical stabilizer, elevators, and rudder.

The wing kit was next and that was finished in December 2013. The wing kit also includes the flaps and ailerons.

I ordered a quick-build fuselage, which means it was mostly assembled with a lot of the final finish work to be done. That was completed around November 2014.

Then it gets a bit blurry as many things started to go together at the same time, including the avionics, finish kit, and firewall forward (engine and accessories).

I started to lease a hangar at CID in the fall of 2018 and many of the finished components, such as the wings were moved there then. The fuselage was moved to the hangar the following March (waiting for warmer weather) and the final assembly began. This included reattaching the empennage and the wings for the final time. Work was also done on the wing tips and lighting, installing the interior seats and belts.

The final DAR (Designated Airworthiness Representative) inspection was on October 15, 2019. But there was a lot of scrambling prior to that date to get

the first engine start done. There were a couple squawks to track down. The first was having the flywheel orientation wrong causing the magneto timing to be off. The second issue was harder to track down, but the electronic ignition was working sporadically. It turned out to be a bad connector in the wiring harness for the crank sensor.

I spent three days in Minneapolis at Crystal airport (MIC) for transition training with Tom Berge. My insurance required just one hour of dual instruction, which seemed very low. Tom and I flew almost 5 hours going over all the characteristics of flying a Vans Aircraft model airplane.

Tom's plane is an RV7A with a constant speed propeller, but the constant speed was not an issue as we pretty much left it alone. I was also lucky enough to get almost an hour of time in an RV9A that was just brought to MIC and is owned by a friend of Tom's there. The owner was gracious enough to let Tom and I fly for the cost of some fuel. The RV9A time was nice, because the aileron roll rate / response is much different (slower) than the RV7A.

First flight was November 9, 2019. I used the Additional Pilot Program outlined in advisory circular AC 90-116 and had Dave Lammers sit in the right seat as the qualified safety pilot. I felt his experience and additional eyes inside the cockpit watching engine instruments

(Continued on page 7)



(Continued from page 6)

would be very helpful. Out of this flight came a few squawks, including a heavy right wing, slight brake line leak, missing panel indicators for the trim system, and aileron trim wired backwards. Additionally, I was experiencing fairly high CHT temps on the climb out, which was mitigated by increasing the climb speed and reducing the power a bit.

Overall it's been a great experience, and the plane now has nine hours of flight time. During the first 40 hours, the plane is in "Phase 1" which limits my travel distance to 35 nautical miles around the CID airport.

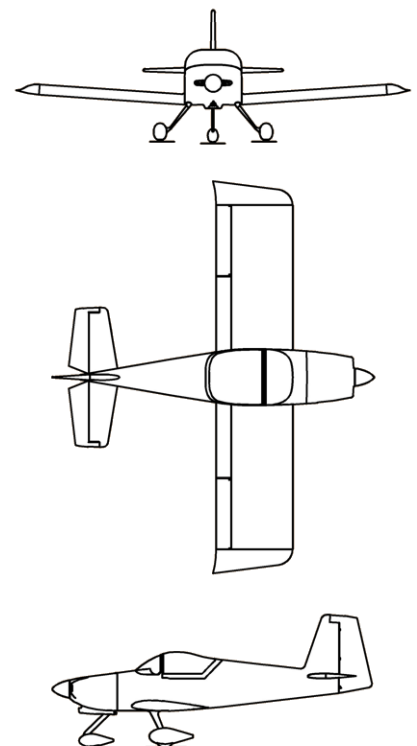

A Long Cross-Country: Flight to Greenland!

by Minnetta Gardinier

A funny thing happened on the way home from AirVenture last year. On Friday, July 26th, I was in my car heading home to Iowa City. On Tuesday, July 30th, I had a one-way ticket to St. John's, Newfoundland (CYYT).

I was going to fly with someone whom I'd never met, in a plane I'd never flown before, to a place I've never been. It was the adventure of a lifetime - flying in a Beech Bonanza to Kangerlussuaq, Greenland (BGSF) and then across Canada to her home base in Bellingham WA (KBLI).

Maureen Griggs is a member of the Washington Pilots Association, has logged 5,000+ hours, and is currently flying her 1968 Beech Bonanza. We had discussed this trip over a year ago, but the timing wasn't going to work out for me. Unexpectedly, her co-pilot was dropping out in St. John's, and Mo was faced with flying home to B'ham. Erin, a mutual friend, re-connected us, and after several conversations with Erin, Mo, and a few of my pilot buddies, I decided to jump in.

Mo had meticulously planned the trip with all the safety considerations - e.g., emergency kit, life raft, sat phone, cold-water immersion suits. She had been in touch with all of the airports and confirmed fuel supplies. So I only needed to collect my gear, pack some clothes, and go.

Wednesday morning (Jul 31), we launched for a short

hop to Gander, Newfoundland (CYQX). Given that I was not previously checked out in the high performance Bonanza, I signed on as a right seat co-pilot in charge of radios, flight planning, traffic, and weather. On this short leg, I discovered one critical item that I had neglected - seat elevation. My Cardinal (C177) seat is height adjustable, but the Bonanza is not. So for leg #2 to Goose Bay, Labrador (CYYR), I was sitting on a sleeping bag.

Thursday morning (Aug 1), we left Goose Bay for Schefferville, Quebec (CYKL) with me sitting on my 2 new kitchen chair seat cushions). For 100LL, you are required to supply your own hand transfer pump for fueling from the 55-gal drum of fuel that was purchased. Mo talked them into saving the left-over fuel for our return flight. Our next 2 stops - Kuujuaq (Quebec; CYVP) and Iqaluit (Nunavut; CYFB) - required the same for fueling - purchasing a 55-gal drum, hand pumping.

We were now in more remote territory; lots of lakes, rivers. It was not uncommon to hear French being spoken on the radios in Quebec province. Weather was IFR, although we were often between layers or in broken clouds. Weather radar was no longer available up here. For search & rescue purposes, we were meticulous with filing flight plans, making position announcements, and sticking to published air routes.

Kuujuaq line service offered little assistance with the fueling, and were nowhere to be found when our hand pump broke. Fortunately, a *Transport Canada* shop was on the field, and the staff were immensely helpful - 1st trying to fix the pump, and 2nd bringing in a small pump from home on the next morning. Our next stop also required a hand pump; however, they had one for customers to use. The other concern was assurance that 100LL supplies were sufficient to refuel for the jump to Greenland AND to refuel on the return. They were down to only 4 barrels, but then the ship came in for us, literally...1200 barrels. So we were good to proceed.

Friday morning (Aug 2), we launched out of Kuujuaq for

(Continued on page 9)



Mo and I at fuel stop #1 - Gander, Newfoundland

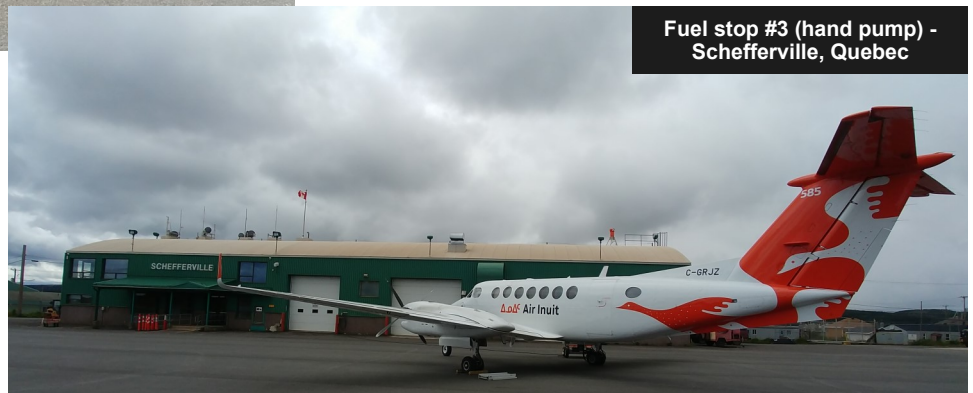

Fuel stop #3 (hand pump) - Schefferville, Quebec

(Continued from page 8)

Iqaluit (formerly Frobisher Bay), which lies about 200 nm from the Arctic Circle. We would cross the Hudson Strait, which is about 100 nm wide at our crossing point. We decided that this would be the time to don the cold-water immersion suits for safety and to acclimate to flying in them for the upcoming crossing to Greenland. In the plane, we wore them half-on with the upper body half tucked behind us. The heavy neoprene rubber suit is rated to maintain body temp for several hours, if we went down and had to abandon the plane for the life raft. They were surprisingly "comfortable" to fly in.

Because Mo needed to ensure that all the paperwork for the trip to Greenland was in order, we decided to spend the weekend in Iqaluit. Time to explore a very remote area accessible only by boat and plane (pop. 7,740). People were very friendly and helpful. It is the capital city of the Nunavut Territory, which is only 20 years old after having split off from the Northwest Territories. A mix of rustic and modern.

On Monday morning (Aug 5), weather was good. We would make the crossing at 10,000 ft, above a cloud layer with sun and blue sky above us. After leaving Iqaluit, we'd fly across Baffin Island and then make the hop across the Davis Strait to Kangerlussuaq, on the west coast of Greenland. We flew up a deep fjord to land at its eastern end. BGSF was previously Sondrestrom USAFB (1941-1992), and the city is effectively the airport (pop. 499), accessible by boat and plane.

We planned to stay until Wednesday and to enjoy a day trip around the Russell Glacier, above the Arctic Circle. The "bus" trip to the glacier was on Greenland's longest highway - 32 miles long - and then along a deeply rutted sand road. The area is a desert tundra. Musk ox and reindeer are prevalent. As we approached the glacier, the driver pointed out the mountain behind it - a year ago, the mountain would have been hidden behind the glacier. The rate of glacier melt is unprecedented. It was great to be out stretching our legs after a week in the plane, but after a day-long hike, we looked forward to a quiet evening of flight planning for our return.

Wednesday morning (Aug 7), we held for awhile waiting for ceilings to come up. Shortly before noon, we launched for the flight back to Frobisher Bay. Again at 10,000 ft, we were above a cloud layer with blue sky overhead. Flying along in our "Muppet" suits. The flight back was smooth, and it was late enough in the day, we spent the night again at our little B&B, and at dinner, we celebrated achieving Mo's mission of flying to Greenland.

Chapter 2 of the adventure was now crossing Canada going west and then to Mo's home base KBLI. For her, it



En route to the Russell Glacier - crash site of a U.S. training jet from the 1960s - undisturbed! The pilots ejected safely.



Frobisher Bay with little icebergs floating; at low tide, it empties out, stranding the 'bergs.



Mo and I after landing in Iqaluit (Frobisher Bay) - we tested the cold-water immersion suits crossing the Hudson Strait (100 nm).



Broken ice below as we are flying into the Frobisher Bay area.

was a “re-run”; for me, it was new territory - across Quebec, Ontario, Manitoba, Saskatchewan, and Alberta - before dropping back into the U.S.

Thursday morning (Aug 8), we took off on retracing our flight to Kuujuaq and to reclaim our remaining fuel drum. Yes, Transport Canada was ready and waiting for us with the fuel pump they had previously let us use. But after topping off, the Wx forecast was not in our favor (low IFR, possible convective activity). So we laid over at the Kuujuaq Inn for 2 nights waiting for better Wx.

On Saturday (Aug 10), we decided that we could launch IFR with higher ceilings and no thunderstorms on our route. We would start our flight west with a fuel stop at La Grande Riviere (CYGL; Quebec) and our next overnight in Moosonee (CYMO; Ontario) - both along the southeastern shores of the Hudson Bay. As the clouds pulled back, we were treated to an emerald green land with many trees - a welcome sight after several days in the tundra north.

Moosonee (pop. 1481) lies along the Moose River and is “the Gateway to the Arctic,” and yes, back in the land of the killer mosquitos. It was a pleasant evening at a small family-run B&B with a burger night at the workers’ lodging house down the road. Sunday, we explored the area and took a water taxi over to hike around Moose Factory Island, a small Cree First Nation community.

Monday morning (Aug 12), we were now heading west across Canada with the goal of landing in Bellingham by Friday. After a quick fuel stop in Geraldton (CYGQ; Ontario) and an overnight in Dryden (CYHD; Ontario),

Tuesday morning (Aug 13), we flew across Canada’s Midwest prairies. The land below us began looking more like “home” for me - roads, a divided highway, big and small farms with checkerboard fields. Overflying Winnipeg, a big city sprawled out below us. Deviating a bit north, we enjoyed the view of Lake Winnipeg below us. We made a fuel stop in Brandon (Manitoba) and an overnight stop in Regina (Saskatchewan), It was time for the Bonanza to get an oil change, and AeroCentre FBO provided top-notch service.

Wednesday morning (Aug 14), we are now looking forward to our return to the U.S. We landed in Lethbridge (CYQL; Alberta) to file our documents for landing in Cut Bank MT (KCTB). Clearing customs was quick, and we made a short hop over Glacier National Park to Kalispell (KGPI) enjoying the next day in Whitefish MT.

On Friday (Aug 16), we enjoyed a great flight to

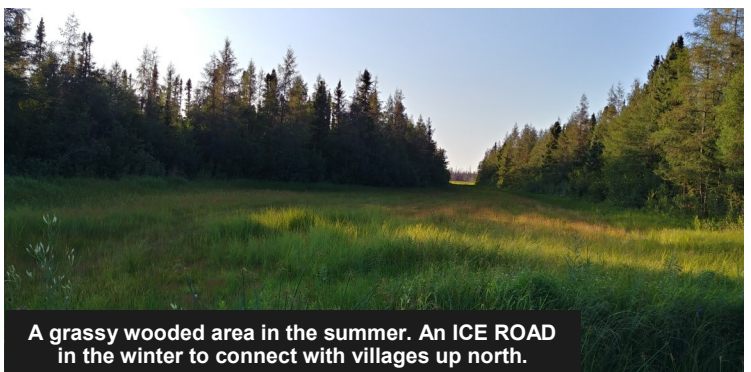

EAA 33 Leadership 2020

President	Justin Cook	president@eaa33.org
Vice President	Minnetta Gardinier	vice-president@eaa33.org
Secretary	Jeremy Williams	secretary@eaa33.org
Treasurer	Brad Cook	treasurer@eaa33.org
Directors	Tom Caruthers Casey Hansen Dave Lammers Dave Miles Eric Smyth	board@eaa33.org
Education	Tim Busch	education@eaa33.org
Flight Advisor	Dave Lammers	flight-advisor@eaa33.org
Membership	Dan Meyer	membership@eaa33.org
Newsletter	Minnetta Gardinier	newsletter@eaa33.org
Program	John Chargo	program@eaa33.org
Scholarship	Jeremy Williams	scholarship@eaa.org
Social Events	OPEN	social@eaa33.org
Tech Counselor	Tom Olson	tech-counselor@eaa33.org
Web	Minnetta Gardinier	web@eaa33.org
Young Eagles	Justin Cook Connie White	young-eagles@eaa33.org

Bellingham WA, the end of our grand adventure. We climb to 14,000 ft and use oxygen as we fly over the Rockies. We pass over the Grand Coulee Dam and then see the snow-capped mountains ahead. A stunning Mt. Shasta peak rises through the clouds. We descend and are vectored into the Sea-Tac traffic flow and up north to BLI. Before us, Bellingham Bay opens up. The BLI tower welcomes Mo back. Mo's BLI buddies are all gathered to welcome her home and to meet her "mystery" co-pilot. After lunch with the gang, I take off to meet up and spend the weekend with my friend Erin and her partner Shanna, who teamed me up with Mo and made it all possible.

Fly by Mount Shasta



As we crossed the mountains between Cut Bank and Kalispell, we passed south of a heavy shower and caught a full rainbow.

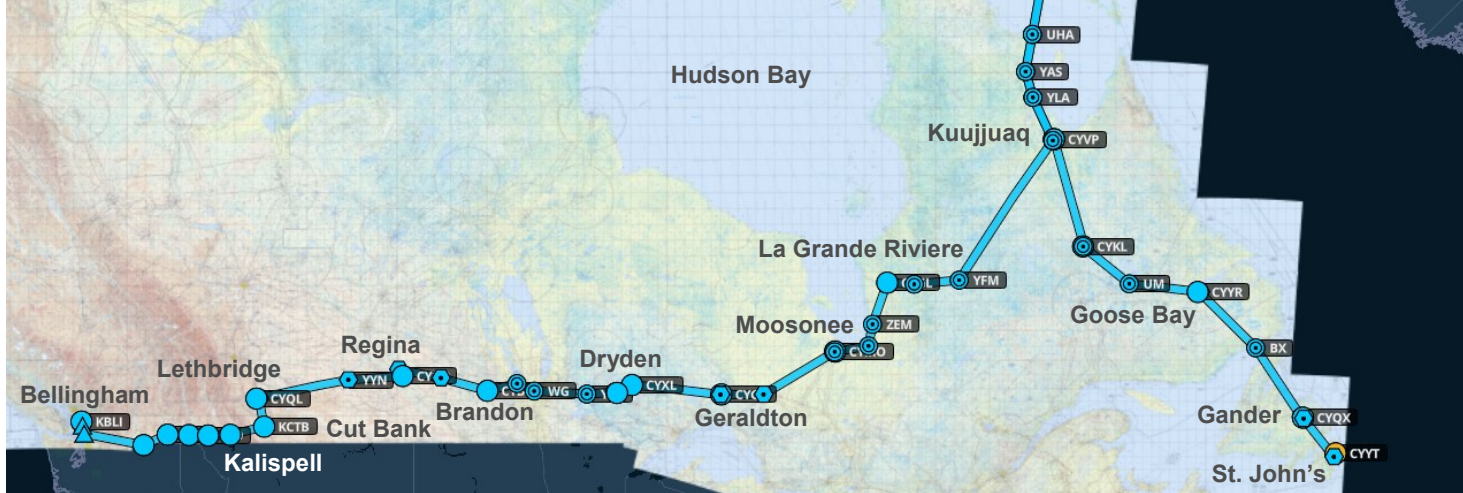

2020 Calendar

Our meetings are scheduled for the **4th week of each month**

Thursdays - Board meeting, 6 pm; General meeting, 7 pm

OR Saturdays - General meeting, 10 am

Thu January 23 – Board & Chapter meeting (CID Public Safety Center)

Sat February 22 – Chapter meeting

Thu March 26 – Board & Chapter meeting

March 31 - April 5 – SUN n FUN Aerospace Expo (LAL, Lakeland FL)

Thu April 23 – Spring Social?

Thu May 28 – Board & Chapter meeting (C17, Marion)

Sat June 27 – Chapter Fly-Out (OSH)

July 20-26 – EAA AirVenture (OSH, Oshkosh WI)

Thu August 27 – Board & Chapter meeting (IOW Conference Rm, 2nd flr)

Sat September 26 – Chapter meeting

Thu October 22 – Board & Chapter meeting

Thu November 12 – Fall Social?

December – No meeting

Check the EAA 33 web calendar for most current details ~ <http://www.eaa33.org>

Aviation enthusiasts promoting and supporting recreational flying

Contact Us

EAA Chapter 33

3435 Beech Way SW
Cedar Rapids, IA 52404

(319) 373-3971

EAAChapter33@yahoo.com

Visit us

Web - www.eaa33.org

Facebook -

[https://www.facebook.com/](https://www.facebook.com/EAA-Chapter-33-155000567861749/)

EAA-Chapter-33-
155000567861749/

PLACE
STAMP
HERE

EAA Chapter 33

3435 Beech Way SW
Cedar Rapids, IA 52404

