



## NEWSLETTER

# Carb Heat

Hot Air and Flying Rumours

Published by EAA Chapter 245 (Ottawa) P.O. Box 8412 Main Terminal, Ottawa, Ontario, Canada, K1G 3H8

## JULY-AUGUST 1992

**NEXT MEETING: SATURDAY 18th JULY 1000 HRS**

**PLACE: EAA 245 Chapter Lounge  
Carp Airport**

### TOPICS:

- ANNOUNCEMENTS
- OSHKOSH BRIEFING
- VIDEO
- CONSTRUCTION OF PIC NIC TABLES
- REFRESHMENTS

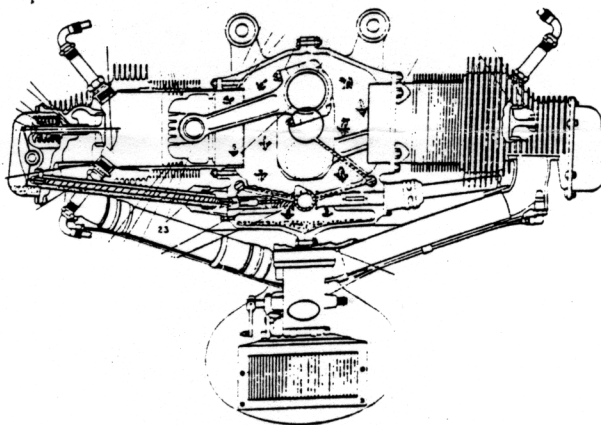

Continental models C75, C85, C90 and O-200 Aircraft Engines

President: Lars Eif	837-6680	Aircraft Operations: Dick Moore	836-5554
Vice-president: Gary Palmer	596-2172	Membership: Manfred Ficker	839-2292
Secretary: Luc Martin	744-5347	Tool Crib: Andy Douma	591-7622
Treasurer: George Elliott	592-8327	Classifieds: Andy Douma	591-7622
Editor: James Oliff	724-6123	Publishing: Dick Moore	836-5554
Assistant Editor: Andy Douma	591-7622		

# President's Corner

## June Meeting

'Sorry about the confusion on the location for the June meeting, but all's well that ends well. We had a good crowd out anyway. In an effort to cheat the mosquitoes at the airport out of yet another free meal, we were going to meet at the Museum. As luck would have it, the Museum is in the process of renovating the theatre, so it was back to Carp again. John Bradley says that the theatre will be better than ever in the fall when we are ready to begin meeting there again. It will also be able to accommodate a bigger group in more comfortable seats, so the wait will be well worth it.

## Work Schedule

As announced at the June meeting, all current members have been assigned a "work day". What this means is that each of us is asked to contribute a few hours of our time this summer to improve our facilities at Carp. For most, this will mean cutting grass, but if you arrive at the airport and find the mowers already in use, don't hesitate to take on other housekeeping chores such as sweeping, painting, cleaning windows, emptying the trash cans or just plain tidying up. If you discover to your horror that your assigned day has passed and you didn't or couldn't make it out, just pick another day to come out and pitch in.

## Oshkosh Bound?

At the July meeting, we will show the 1992 FAA Oshkosh arrivals procedure video. It is essentially the same as last year, but if you are flying to Oshkosh this year, a refresher can't hurt. I will also have copies of the FAA NOTAM available for anyone who is flying down.

Also, each year we receive letters from EAA chapters who offer enroute facilities for weary Oshkosh-bound and homeward-bound pilots. This year, EAA Chapter 104 wants you to stop in. EAA

104 is located at Valparaiso, Indiana Porter County Municipal Airport and offer food, fuel and rest during the period July 28-Aug 6, 1992. Copies of their instruction sheet will be available at the July meeting.

## Terra Field Bed and Breakfast

We also received a letter from Bill and Carol Terra who operate an aviation B&B in West Levant, Maine. They have very comfortable guest quarters and a 2600 foot grass strip available for all pilots who would like to visit them. Rates are reasonable and vary with the size of room. Call (207) 884-8805 for information or see me for a photocopy of their flyer.

## EAA Young Eagles Program

This is a program which you will hear about a lot over the next 11 years. In an effort to foster a favourable awareness of aviation in the next generation of adults, EAA has established the ambitious goal of taking 1,000,000 youngsters for an airplane ride between now and the year 2003, the 100th anniversary of powered flight. We will have a video available at the July meeting which gives all the details. This is a very worthy program which pilots can participate in as individuals or support through organized chapters events. Incidentally, EAA can provide liability insurance for its members to give familiarization rides to youngsters, so there is no reason why we can't support this worthy cause as a Chapter in the coming years.

Well, that's it for this month. Make sure you come out to the July meeting. I know you will enjoy seeing John Richards' beautiful Zenair CH300 in its resplendent new paint job. John is waiting for his paperwork and final inspection so that he can have that special first flight done on the Zenith. There's something magical about a brand new aircraft that hasn't flown yet. Come out and enjoy!

MINUTES OF MEETING JUNE 18th - CARP INTERNATIONAL AIRPORT

Subjects Discussed:

The Raqwing Air Command Fly-In/Drive-In:

Attendance was poor but from the reaction of those who were there, the idea was a good one. We should think about getting more involved in this event next year. According to Greg Reynolds, this event should take place over one day instead of two.

The chapter now has a group dedicated to the electricity issue. This group will be producing an overview and cost projection in the near future. Stay tuned.

Our sub-lease for five years is about to be signed, Lars will have more news on this at the next meeting.

Lars and I received certificates of appreciation for serving the chapter.

Our intrepid friend, Stan Kewituk, was presented with an award for offering his test pilot skills to several members of the chapter on completion of their amateur built aircrafts. Thank you for the implied confidence in the quality of our aircraft.

Gary fancy received his fourth first flight award for his Husky Cuby. Gary Palmer received a first flight award for his Lancair.

Laurent Ruel who works constantly to make sure that the facility at Carp stays in good shape was presented with a five year membership to the club. Thank you Laurent for all those hours spent in the generator shed.

Our next meeting will be held on August 15<sup>th</sup> at the hanger. We will be building new picnic tables afterwards so bring your toolbox along.

Display at the National Aviation Museum - Canada Day:

We got to the museum bright and early to set up our display board - a nice piece of work built by Richard Jones. Assorted literature was displayed on available tables. Barney de Sneider and his son helped with setting things up. Soon after we had 8 aircrafts on display and a nice display it was!

The fly-in breakfast at Rockcliff was underway and a few of us attended, the food was good and the place was busy, the renovated hanger looks very nice.

Later in the day we saw an RV-6 and a Lancair fly by over the runway at somewhere around 140. Oddly enough they were being followed by a Zodiac and a very shiny Geeny's Teenie, who also flew by at well over the double nickel speed. Thus, proving again the superior performance capability of the Amateur Built aircraft I think we made a good impression on the museum and the people who came to look at our display. Thank you to all of the members who made this event a success whether it was by bringing an airplane or by manning the kiosk.

Hope you "commit" aviation.

Luc Martin (S L S)

(Semi-literate secretary)

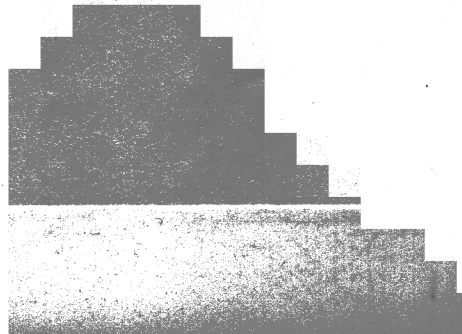

### Construction of new pic-nic tables

For part of our July Meeting we will be constructing five new pic-nic tables (see below). The lumber, hardware and plans will be provided along with the construction formen (Dick and Andy). Please bring your hammer and hand saw if you are able to help out. Thanks, Andy

### Picnic Table

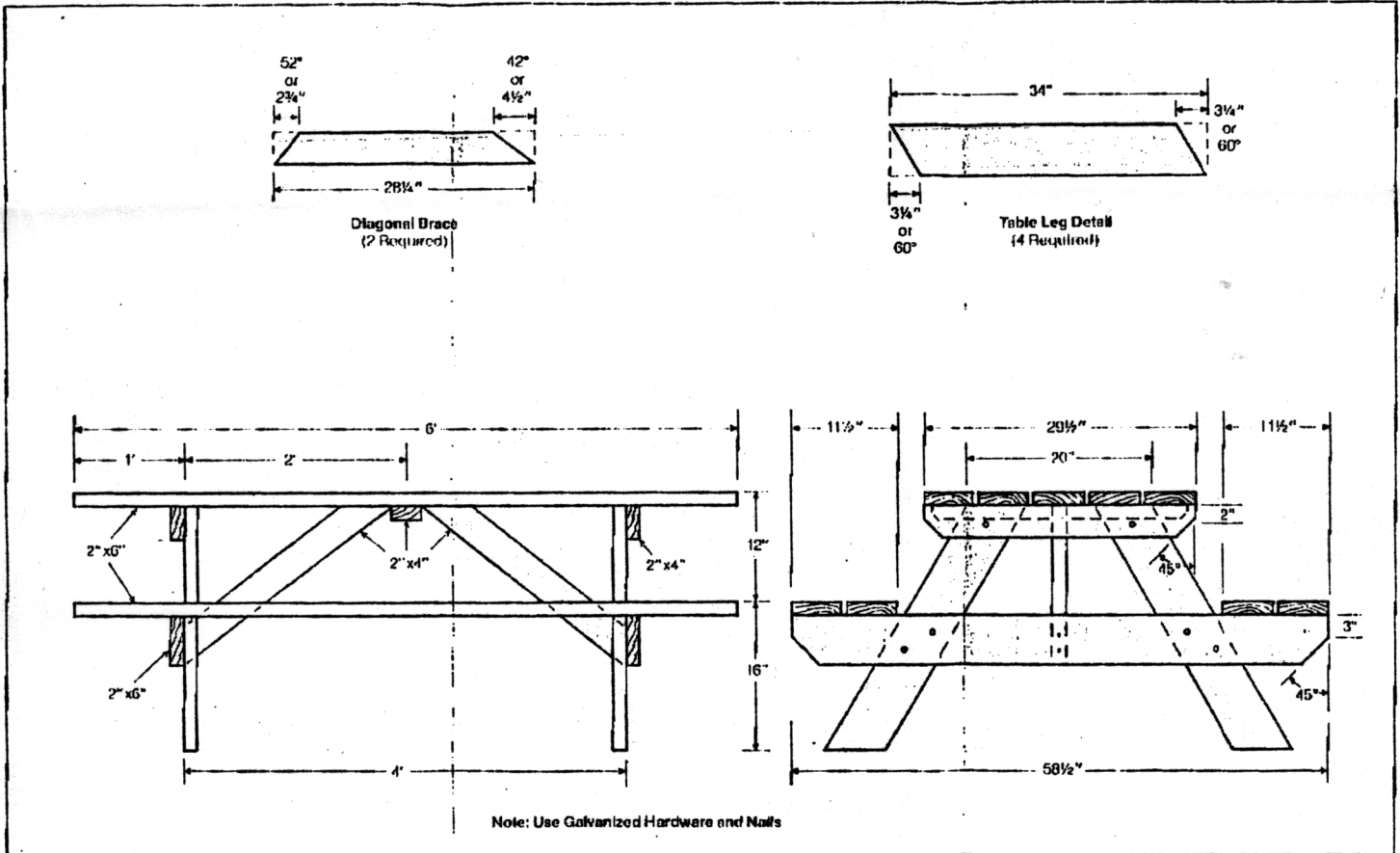

#### What to Buy

##### Lumber

1. Seat, Top, Legs: 6 Pcs. 2" x 6" x 12'
2. Seat Supports: 1 Pcs. 2" x 6" x 10'
3. Table Supports, Braces: 2 Pcs. 2" x 4" x 10'

##### Hardware

1. 12 Galvanized Carriage Bolts: 3/8" x 3 1/2"
2. 12 3/8" Flat Washers
3. Galvanized Nails as Required

# CLASSIFIEDS

08 July 1992

## AIRCRAFT FOR SALE:

Piper PA-25 Pawnee - no engine.  
Piper PA-22 Colt 108hp.  
Stinson 108-3 165hp, 108-1 150hp.  
Cessna 172, 1956 straight tail.

Homebuilt Super CUBy. Completed 1988. 100 TTAF. Lycoming O-320, 100 hrs SMOH; set up for auto fuel. Full gyro panel; 2-20 gallon wing tanks. Excellent condition. Contact Henri Beaudoin at (613) 749-9720.

## PROJECTS FOR SALE:

**!!! NEWCOMERS !!!** Looking to start or finish a project? These partial to nearly completed projects **will save you years of building time and barrels of money.**

Aeronca 15AC (Sedan) Project.  
Mike Sacoutis 729-3774

Baby Great Lakes Project: Fuselage 90% complete; all ribs and spars; Some instruments \$1500. Mike Sacoutis (613) 729-3774.

## PLANS:

PLANS for Davis DA2A. Call Russ Robinson 831-4317.

PLANS and work book for single place midgit Mustang. \$10.00 Phone George Reid at 749-0792.

## PARTS FOR SALE:

Bellanca Scout for parts.

### Engines:

Lycoming O-300C, 1365 hrs; O-300A, 1750hrs; O-300, 1200hrs; O-320E2A, 600hrs.

**Engine Parts:** for Lycoming, Continental, Franklin. Starters, generators, vacuum pumps, oil cooler and cylinder for a 165hp Franklin.

### Engine Mounts:

Piper PA-12, Mooney M-20, Champion 7AC 90hp, Cessna 175 O-300.

### Wheel Pants:

Cessna 172, Stinson 108, Aeronca Sedan.

### Propellers:

**Sensenich** - M74DM-61; M74DM6-0-62 cut to 71"; M74DM6-0-48; M76A-M-2-52

**Harzell** - HC82VL-1D1.

**McCauley** - 1C172-7653; 1C172-EM7653; 1A175-FC8467, -DM7651, -DM7655; 1B90-CM7448

**Gypsy Major** suitable or a clock.

**Pusher Prop**, 76", suitable or a VJ-22

### EDO Float Rigging:

- 89-2000 (deck fittings)  
- C-172 (modern)  
- C-140

Assorted struts.

### Radios:

Narco 122A VOR G/slope, Narco 810 COM, Terra TX720, Genave Alpha 600 N/C, Bendix ADF-F-12C

For all of the above items phone  
**Mike Sacoutis 729-3774**

**INSTRUMENTS:**

Altimeter, VSI, Tachs, DG, Horizon, Compass, Accelerometer, Turn and Bank (electric), CHT-EGT, Airspeed, Manifold Pressure.

Call Mike Sacoutis 729-3774.

Compass, Airpath C2400 L4P, pedestal mount, new & unused still in the box. \$75.00, call Gord Standing 224-2879.

Vari Eze landing gear legs. New. Call Peter Plaunt (613) 839-2283.

Randolph butyrate dope in unopened gallon containers; 1 gallons clear; 1 gallon Juneau white; 1 gallon Piper Lockhaven yellow (Maule yellow); 1 gallon insignia blue.

- 2 large oil coolers (~8x9")
- 1 hydraulic pump
- 1 vacuum pump
- 1 Lycoming dual accessory case adapter for above pumps.
- Spinner, pointed, 11" base.
- piston rings for Continental E-185-3.

Cylinders, four, Lycoming IO-360, wide deck, fresh chrome. Garry Fancy 836-2829.

Propeller, Hartzell HC82XL-2C constant speed plus governor for 320 - 360 Lycoming engines. Garry Fancy 836-2829.

For the above items contact **Garry Fancy (613) 836-2829**

Propeller, three bladed, ground adjustable, wooden blades, metal hub with spinner. Fits VW hub \$250.00.

Guages, Westach 2 1/2 " square manifold pressure/ turbo boost. Brand new in the box \$50.00.

Autopilot, Federal, new, 2-axis, STC included for installation in C-172 A.B.C., \$250.00.

For the above items contact **Tim Robinson at (613) 824-5044** evenings.

**WANTED:**

Two fuel tank caps, large Piper type. Phone Garry Fancy 836-2829.

**OTHER:**

The "Canadian Amateur Built Aircraft Registry" is now available from CASTC. Call Ted Slack at 226-8373.

PLACE YOUR ADS BY PHONING  
ANDY AT 591-7622  
Classifieds Editor

**CALENDAR OF EVENTS**

**JULY 1992**

1 Rockcliffe, Fly-n Breakfast and National Air Museum Displays. EAA Chapter 245 participation.

12 Arnprior, COPA Flight 33 Fly-in Breakfast.

18 EAA 245 Monthly meeting Carp Airport 1000hrs.

19 Iroquois, 26th annual Fly-in Breakfast.

31- Oshkosh Wisconsin, EAA Annual Fly-in Convention.

**AUGUST 1992**

- 6 Oshkosh Wisconsin, EAA Annual Fly-in Convention.

6 Alexandria Fly-In Breakfast.

15 EAA 245 Monthly meeting Carp Airport 1000hrs.

23 EAA 245 Annual Fly-In Breakfast Carp Airport.