



GMA 340 AUDIO PANEL INSTALLATION MANUAL

(GMA 340, GMA 340H,
GMA 340 DUAL ADF)



(GMA 340 and GMA 340 Dual ADF Shown)



Garmin International, Inc.
1200 E. 151st Street
Olathe, KS 66062 USA

190-00149-01 Revision L
June 2003

Except as expressly provided herein, no part of this manual may be reproduced, copied, transmitted, disseminated, downloaded or stored in any storage medium, for any purpose without the express prior written consent of Garmin. Garmin hereby grants permission to download a single copy of this manual and of any revision to this manual onto a hard drive or other electronic storage medium to be viewed and to print one copy of this manual or of any revision hereto, provided that such electronic or printed copy of this manual or revision must contain the complete text of this copyright notice and provided further that any unauthorized commercial distribution of this manual or any revision hereto is strictly prohibited.

Information in this document is subject to change without notice. Visit the Garmin web site (www.garmin.com) for current updates and supplemental information concerning the operation of this and other Garmin products.

Garmin International, Inc.
1200 E. 151st Street
Olathe, KS 66062 USA
Telephone: 913-397-8200
Aviation Panel-Mount Technical Support Line (Toll Free) 1-888-606-5482
Dealer Line: 1-800-800-1420
Web Site Address: www.garmin.com

Garmin (Europe) Ltd.
Unit 5, Quadrangle, Abbey Park Industrial Estate
Romsey, SO51 9DL, U.K.
Telephone: 44/1794.519944

INFORMATION SUBJECT TO EXPORT CONTROL LAWS

This document may contain information which is subject to the Export Administration Regulations (“EAR”) issued by the United States Department of Commerce (15 CFR, Chapter VII, Subchapter C) and which may not be exported, released, or disclosed to foreign nationals inside or outside of the United States without first obtaining an export license. A violation of the EAR may be subject to a penalty of up to 10 years imprisonment and a fine of up to US\$1,000,000 under Section 2410 of the Export Administration Act of 1979. Include this notice with any reproduced portion of this document.

RECORD OF REVISIONS

Revision	Revision Date	Description	ECO #
A	01/27/98	Preliminary Release	-
B	03/05/98	Add Music Trip Level Adjustment	8512
C	02/03/99	Add Marker Sens Adjustment and Crimp Tool P/N	10404
D	02/15/99	Add JTSO's	10487
E	05/28/99	Updated Document	11122
F	05/26/00	Redraw	13446
G	04/27/01	Add 340H P/N, STC, Mod 1 Normal/Split Com Mode Connections, Helicopter PTT Switch	15687
H	05/18/01	Added Dual ADF Version	15847
J	12/18/01	Add mono/stereo failsafe note	17123
K	06/24/02	Add 20 dB Music Volume Control and mod history	18443
L	06/30/03	Add SB0213 and SB0221	21559

TABLE OF CONTENTS

SECTION 1 GENERAL INFORMATION

PARAGRAPH	PAGE
1.1 INTRODUCTION.....	1-1
1.2 GENERAL DESCRIPTION	1-1
1.3 SPECIFICATIONS	1-2
1.4 EQUIPMENT.....	1-3
1.5 INSTALLATION ACCESSORIES	1-3
1.6 ADDITIONAL EQUIPMENT REQUIRED.....	1-4
1.7 LIMITED WARRANTY	1-5

SECTION 2 INSTALLATION

2.1 INTRODUCTION.....	2-1
2.2 UNPACKING AND INSPECTING EQUIPMENT.....	2-1
2.3 ANTENNA INSTALLATION.....	2-1
2.3.1 Location Considerations.....	2-1
2.3.2 Antenna Installation.....	2-1
2.3.3 Antenna Cable Installation.....	2-1
2.3.4 Installation Approval Considerations for Pressurized Aircraft	2-2
2.4 GMA 340 INSTALLATION.....	2-2
2.5 REAR CONNECTIONS	2-3
2.5.1 Location.....	2-3
2.5.2 Audio Shield Termination.....	2-5
2.5.3 Noise.....	2-6
2.6 POST INSTALLATION CHECKOUT	2-6
2.6.1 Lamp Test.....	2-6
2.6.2 Failsafe Operation Check	2-7
2.6.3 Transceiver Operational Check	2-7
2.6.4 Intercom System (ICS) Check.....	2-7
2.6.5 Aircraft Receivers Check.....	2-8
2.6.6 Music System Check	2-8
2.7 ADJUSTMENTS	2-9

**SECTION 3
OPERATION**

PARAGRAPH	PAGE
3.1 OPERATION	3-1
3.1.1 Front Panel Controls.....	3-1
3.1.2 On, Off, and Failsafe Operation	3-2
3.1.3 Lighting	3-2
3.1.4 Transceivers	3-2
3.1.5 Split Com.....	3-3
3.1.6 Com Swap Function	3-3
3.1.7 Aircraft Radios & Navigation	3-3
3.1.8 Speaker Output.....	3-3
3.1.9 PA Function.....	3-4
3.1.10 Auxiliary Entertainment Inputs	3-4
3.1.11 Intercom System (ICS)	3-4
3.1.12 Mono/Stereo Headset	3-5
3.1.13 Marker Beacon Receiver	3-6

**APPENDIX A
CERTIFICATION DOCUMENTS**

A.1 CONTINUED AIRWORTHINESS	A-1
A.2 ENVIRONMENTAL QUALIFICATION FORM	A-4

**APPENDIX B
INSTALLATION DRAWINGS**

B.1 GENERAL	B-1
-------------------	-----

**APPENDIX C
STC PERMISSION**

C.1 GENERAL	C-1
-------------------	-----

LIST OF ILLUSTRATIONS

FIGURE	PAGE
2-1 REAR CONNECTORS.....	2-3
2-2 AUDIO SHIELD TERMINATION	2-5
2-3 ACCESS HOLE LOCATION.....	2-9
3-1 GMA 340 FRONT PANEL.....	3-1
B1 GMA 340 OUTLINE DRAWING	B-3
B2 CONNECTOR/RACK KIT DRAWING	B-5
B3 GMA 340 RECOMMENDED PANEL CUTOUT DIMENSIONS	B-7
B4 J1 INTERCONNECT WIRING DIAGRAM	B-9
B5 J2 INTERCONNECT WIRING DIAGRAM.....	B-11
B6 J1 INTERCONNECT WIRING DIAGRAM.....	B-13
B7 J2 INTERCONNECT WIRING DIAGRAM.....	B-15

LIST OF TABLES

Table	PAGE
2-1. J1 and J2 Pin Assignments.....	2-4
2-2. Recommended Crimp tools.....	2-5

GMA 340 HARDWARE MOD LEVEL HISTORY

The following table identifies hardware modification (Mod) Levels for the GMA 340 audio panel. Mod Levels are listed with the associated service bulletin number, service bulletin date, and the purpose of the modification. The table is current at the time of publication of this manual (see date on front cover) and is subject to change without notice. Authorized Garmin Sales and Service Centers are encouraged to access the most up-to-date bulletin and advisory information on the Garmin Dealer Resource web site at www.garmin.com using their Garmin-provided user name and password.

MOD LEVEL	SERVICE BULLETIN NUMBER	SERVICE BULLETIN DATE	PURPOSE OF MODIFICATION
1	0103	2-2-01	Configurable option to mute other com audios when transmitting.
2	0113	6-13-01	Provides times ten gain (20 dB) for entertainment music system.
3	0208B	5-17-02	Provides correct marker beacon output loading for interface with a Sandel SN3308 EHSI.
4	0209	5-2-02	Provides failsafe operation when monophonic headsets are used in a stereo installation.
5	0210	5-2-02	Provides switchable On/OFF times ten gain (20 dB) for entertainment music system.
6	0212	7-16-02	Filter capacitors added to prevent power supply noise from interfering with a GDL 49.
7	0213	8-26-02	Prevents current limiting resistors from becoming shorted to the chassis.
8	0221	*	Adds a failsafe warning audio to the GMA 340.

* Not released at time of publication.

SECTION 1

GENERAL INFORMATION

1.1 INTRODUCTION

This manual provides the installation and operating instructions for the Garmin GMA 340, GMA 340H and GMA 340 Dual ADF Audio Panel. Reference to GMA 340 throughout this manual refers to all versions of the unit. Information pertaining to the maintenance of the unit can be found in the GMA 340 Maintenance Manual, P/N 190-00149-02. After installation of the GMA 340, FAA Form 337 must be completed by an appropriately certificated agency to return the aircraft to service.

1.2 GENERAL DESCRIPTION

The Garmin GMA 340 Audio Panel meets the needs of aircraft owners and operators who require reliability and versatility in the essential audio switching function. LED-illuminated push-button simplicity and intuitive panel layout allow audio selection of both NAV and COM audio. Large, single-button activation of the COM microphone and audio for up to three COM transceivers simplifies cockpit workload. Photocell dimming circuitry automatically adjusts the brightness of the LEDs to a level appropriate for ambient cockpit light. A fail-safe circuit connects the pilot's headset and microphone directly to COM1 in the event that power is interrupted or the unit is turned off. In the event of power loss a fail-safe warning audio will be heard.

Additionally, the GMA 340 includes a six-position intercom (ICS) with electronic cabin noise de-emphasis, two stereo music inputs, and independent pilot, copilot, and passenger volume controls. To further simplify the cockpit workload, the intercom provides three selectable modes of isolation. One hundred percent solid state circuitry and extensive use of surface mount technology are employed. A pilot-selectable cabin speaker output can be used to listen to the selected aircraft radios or to broadcast PA announcements. The PA function is pilot selectable.

The GMA 340 is FAA TSO approved to C50c and C35d and JTSA approved to C50c and 2C35d. Also standard is the marker beacon receiver with dual sensitivity and audio muting with automatic re-arming. 14V or 28V operation, including the full rated range of headphone and speaker output power, is available without the requirement for external voltage converters or dropping resistors. The GMA 340 is the standard version audio panel as pictured on the cover of this manual. The GMA 340H is the helicopter version in which the pilot and copilot control knobs on the front panel are reversed. The GMA 340 Dual ADF version, also pictured on the cover, accepts two ADF audio inputs.

Features Summary:

- User-friendly, intuitive front panel layout
- LEDs indicate selected function
- Six position intercom: pilot, copilot, four passengers
- Three stereo headset amplifiers: one for pilot, one for copilot, and one for the passengers
- Two stereo music source inputs (one in Dual ADF version)
- Three selectable intercom operational modes
- Selectable aural pushbutton annunciation (beep) for the crew.

- Independent pilot, copilot, and passenger volume controls
- Individual VOX circuits for each of six (6) mic inputs
- Automatic selection of radio audio source when corresponding mic is selected
- **MASQ™** Processing
- Split COM transceiver function. Copilot may transmit and receive on COM2 while pilot transmits and receives on COM1
- COM swap function
- TX indication
- **SmartMute™** marker audio muting
- Speaker output for radios or PA function
- Power-off fail-safe to connect Pilot PTT, mic, and Headset to COM 1 if unit is turned off
- Power loss fail-safe warning audio

1.3 SPECIFICATIONS

SPECIFICATION	CHARACTERISTIC
TSO Compliance	TSO-C50c, C35d, JTSO-C50c, and JTSO-2C35d using DO-160C, DO-170, and DO-143
Temperature Range	-20°C to +55°C
Weight	(Unit Only) 1.2 lbs. (0.6 kg) (Installed with rack and connectors) 1.7 lbs. (0.8 kg)
Physical Dimensions:	Bezel Height: 1.30 inches (33 mm) Bezel Width: 6.29 inches (160 mm) Rack Height (Dimple to Dimple): 1.33 inches (34 mm) Rack Width: 6.30 inches (160 mm)
Depth Behind Panel with Connectors (measured from face of aircraft panel to rear of connector backshells)	7.12 inches (181 mm)
Power Requirements	Supply Voltage: 11.0 to 33.0 VDC; Operating Current: 2.2 A (normal operation, 13.8 V, speaker on)
Altitude	50,000 Feet
Audio Panel	Transceiver inputs: 3 Receiver inputs: 5 (6 in Dual ADF version) Unswitched inputs: 2 Input impedance: 500Ω (800Ω DME input in Dual ADF) Input isolation: 60 dB minimum Special functions: Fail-safe operation MASQ™ processing

SPECIFICATION	CHARACTERISTIC
Intercom	Positions: 6 (pilot, copilot, 4 passengers) Volume controls: 3 (pilot, copilot, passengers) VOX level controls: 2 (pilot, copilot/passengers) VOX circuits: 6 (one per mic input) Music inputs (stereo): 2 (1 in Dual ADF version) (one input mutable) Music input impedance: 460 ohms minimum Music input level: Less than 500 mVac RMS for full output (typical). 1 Vac RMS MAX (3 Vac p-p) Microphone signal processing: 9 pole characteristic and special cabin noise band de-emphasis Intercom isolation modes: 3 Special functions: Configurable aural push-button annunciation for the crew
Headphone Outputs	Output amplifiers: 3, stereo (pilot, copilot, passengers) Fidelity: <u>Power into 150Ω</u> <u>Distortion</u> 50 mW <0.5% 100 mW <5% Frequency response: music; 100 Hz to 15 kHz nominal Aircraft radio: 100 Hz to 6 kHz nominal ICS mic: (Special cabin noise band de-emphasis)
Speaker Outputs	Outputs selectable: 1, pilot selectable Output power: 10 Watts into 4 or 8Ω, @ any normal supply voltage. Frequency response: 350 Hz to 6 kHz nominal Special functions: PA Mode, pilot selectable, including split operation
Marker Beacon Receiver	Frequency: Crystal controlled at 75 MHz Sensitivity: LO 1000 μV hard; HI 200 μV hard Selectivity: 6 dB @ ±10 kHz min, 40 dB @ ±200 kHz max. Input impedance: 50Ω External lamp drive: 125 mA max each output Other outputs: Middle MKR sense Special functions: SmartMute™ marker audio muting

1.4 EQUIPMENT

GMA 340 Audio Panel, Ship Level Assembly, P/N 010-00152-() includes the following, depending on part number:

- 011-00401-()— GMA 340 Unit Assembly (011-00401-10 replaces 011-00401-00)
- 011-00652-00—Connector Kit, GMA 340
- 011-00678-00—Rack Backplate, GMA 340
- 115-00262-00—SMP, Install Rack, GMA 340

(The installation kit is the same for the GMA 340, GMA 340H and GMA 340 Dual ADF)

1.5 INSTALLATION ACCESSORIES

- Marker beacon antenna kit (P/N 010-10175-00). [Note: A marker beacon antenna approved to TSO C35() that has been installed to meet the requirements of this manual may be approved for use with the GMA 340].

1.6 ADDITIONAL EQUIPMENT REQUIRED

- Antenna sealant (use manufacturer's instructions, install according to FAA AC 43.13-2A).
- Cables: The installer will fabricate and supply all system cables. Interconnect wiring diagrams are detailed in Appendix B.
- Hardware: #6-32 100° flat head screw (6 ea.) and #6-32 self-locking nut (6 ea.). Hardware required to mount the installation rack is not provided.
- Stereo headphone jacks (up to 6), microphone jacks (up to 6), 3.5mm stereo jacks (up to 2), and insulating washers for all.

1.7 LIMITED WARRANTY

This Garmin product is warranted to be free from defects in materials or workmanship for one year from the date of purchase. Within this period, Garmin will at its sole option, repair or replace any components that fail in normal use. Such repairs or replacement will be made at no charge to the customer for parts or labor, provided that the customer shall be responsible for any transportation cost. This warranty does not cover failures due to abuse, misuse, accident or unauthorized alteration or repairs.

THE WARRANTIES AND REMEDIES CONTAINED HEREIN ARE EXCLUSIVE AND IN LIEU OF ALL OTHER WARRANTIES EXPRESS OR IMPLIED OR STATUTORY, INCLUDING ANY LIABILITY ARISING UNDER ANY WARRANTY OF MERCHANTABILITY OR FITNESS FOR A PARTICULAR PURPOSE, STATUTORY OR OTHERWISE. THIS WARRANTY GIVES YOU SPECIFIC LEGAL RIGHTS, WHICH MAY VARY FROM STATE TO STATE.

IN NO EVENT SHALL GARMIN BE LIABLE FOR ANY INCIDENTAL, SPECIAL, INDIRECT OR CONSEQUENTIAL DAMAGES, WHETHER RESULTING FROM THE USE, MISUSE, OR INABILITY TO USE THIS PRODUCT OR FROM DEFECTS IN THE PRODUCT. Some states do not allow the exclusion of incidental or consequential damages, so the above limitations may not apply to you.

Garmin retains the exclusive right to repair or replace the unit or software or offer a full refund of the purchase price at its sole discretion. SUCH REMEDY SHALL BE YOUR SOLE AND EXCLUSIVE REMEDY FOR ANY BREACH OF WARRANTY.

To obtain warranty service, contact your local Garmin Authorized Service Center. For assistance in locating a Service Center near you, call Garmin Customer Service at one of the numbers shown below.

Products sold through online auctions are not eligible for rebates or other special offers from Garmin. Online auction confirmations are not accepted for warranty verification. To obtain warranty service, an original or copy of the sales receipt from the original retailer is required. Garmin will not replace missing components from any package purchased through an online auction.

Garmin International, Inc.
1200 East 151st Street
Olathe, Kansas 66062, U.S.A.
Phone: 913/397.8200
FAX: 913/397.0836

Garmin (Europe) Ltd.
Unit 5, The Quadrangle, Abbey Park Industrial Estate
Romsey, SO51 9DL, U.K.
Phone: 44/1794.519944
FAX: 44/1794.519222

This page intentionally left blank.

SECTION 2

INSTALLATION

2.1 INTRODUCTION

This section provides the necessary information for the installation and checkout of the GMA 340 Audio Panel. Installation of the GMA 340 will differ according to equipment location and other factors. Cabling will be fabricated by the installing agency to fit these various requirements. Appendix B contains interconnect wiring diagrams, mounting dimensions, and information pertaining to installation. Each installation shall be accomplished to meet the requirements of FAA AC 43.13-2A.

2.2 UNPACKING AND INSPECTING EQUIPMENT

Carefully unpack the equipment and make a visual inspection of the unit for evidence of damage incurred during shipment. If the unit is damaged, notify the carrier and file a claim. To justify a claim, save the original shipping container and all packing materials. Do not return the unit to Garmin until the carrier has authorized the claim. Retain the original shipping containers for storage. If the original containers are not available, a separate cardboard container should be prepared that is large enough to accommodate sufficient packing material to prevent movement.

2.3 ANTENNA INSTALLATION

2.3.1 Location Considerations

The marker beacon antenna should be mounted on a flat surface on the underside of the aircraft. Mount the antenna so that there is a minimum of structure between it and the ground radio stations. Locate as far away as possible from transmitter antennas.

Best results with split COM mode will be obtained when the COM 1 and COM 2 antennas are mounted on opposite sides of the aircraft (top/bottom).

2.3.2 Antenna Installation

Install the antenna according to the antenna manufacturer's instructions and FAA AC 43.13-2A.

2.3.3 Antenna Cable Installation

Use coax meeting the applicable aviation regulation for the marker beacon antenna cable. When routing the cable, avoid sharp corners and route away from high current wiring, fluorescent lighting, and any transmitter antenna cables. Follow accepted industry practices when installing the BNC connector at the antenna end of the cable. Use a BNC connector suitable for the type of cable used.

2.3.4 Installation Approval Considerations for Pressurized Aircraft

Antenna and cable installations on pressurized cabin aircraft require FAA approved installation design and engineering substantiation data whenever such installations incorporate alteration (penetration) of the cabin pressure vessel by connector holes and/or mounting arrangements.

For needed engineering support pertaining to the design and approval of such pressurized aircraft antenna installations, it is recommended that the installer proceed according to any of the following listed alternatives:

1. Obtain approved antenna installation design data from the aircraft manufacturer.
2. Obtain an FAA approved Supplemental Type Certificate (STC) pertaining to and valid for the subject antenna installation.
3. Contact the FAA Aircraft Certification Office in the appropriate Region and request identification of FAA Designated Engineering Representatives (DERs) who are authorized to prepare and approve the required antenna installation engineering data.
4. Obtain FAA Advisory Circular AC-183C and select (and contact) a DER from the roster of individuals identified there under.

Contact an aviation industry organization such as the Aircraft Electronics Association and request their assistance.

2.4 GMA 340 INSTALLATION

NOTE

Avoid installing the unit near heat sources. If this is not possible, insure that additional cooling is provided. Allow adequate space for installation of cables and connectors. The installer will supply and fabricate all of the cables. All wiring must be in accordance with FAA AC 43.13-2A.

1. Assemble the connector/rack kit according to table 2-1 and figures B4 through B7. Install the rack assembly according to the dimensions given in figures B1 and B3. Mounting brackets are not supplied due to the wide range of mounting configurations available. Suitable mounting brackets may be fabricated from sheet metal or angle stock. To insure a sturdy mount, rear support for the unit should be provided.
2. Slide the unit into the rack until the jack screw makes contact with the receptacle located in the back plate.
3. Insert a 3/32" Allen wrench into the jackscrew access hole on the faceplate.
4. Turn the Allen wrench clockwise until the unit is secured in the rack. Continue turning until tight, but do not over-tighten.
5. To remove the unit from the rack, turn the Allen wrench counterclockwise until it disengages from the rack.

2.5 REAR CONNECTIONS

2.5.1 Location

The GMA 340 has two 44 pin connectors located at the rear of the unit, designated J1 and J2. J1 and J2 pin assignments are given in table 2-1. When viewed from the back of the rack, J1 and J2 look like the following:

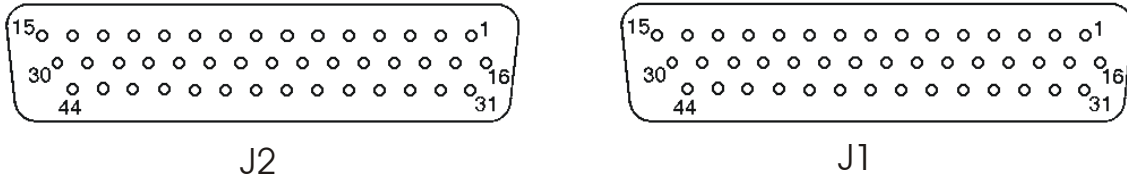

Figure 2-1. Rear Connectors

NOTES

These notes apply to the following table:

* Denotes Active Low. (Ground to activate). Refer to Figures B4 through B7 for GMA 340 interconnect wiring diagrams.

** The GMA 340 provides inputs for an unswitched aircraft radio (TEL RINGER) and an un-muted, unswitched aircraft radio (ALT WRN).

Pin #	Connector J1	Connector J2
1	Mkr Ant	Pilot Headset Return
2	Mkr Ant Return	Co-Pilot Headset Return
3	Com 3 In	Co-Pilot Headset L
4	Com 3 Return	Co-Pilot Headset R
5	Com 3 Mic	14V Lgt Lo/28V Lgt Lo
6	Com 3 Key*	14V Lgt/28V Lgt Lo
7	ADF In (ADF 2 In)	14V Lgt/28V Lgt
8	ADF Return (ADF 2 Return)	Aircraft Power
9	Com 1 In	Aircraft Power
10	Com 1 Return	Aircraft Ground
11	Com 1 Mic	Aircraft Ground
12	Com 1 Key*	PA Mute*
13	Com 2 In	ICS Mute Inhibit*
14	Com 2 Return	ICS Mute Inhibit Return
15	Com 2 Mic	High Music Gain Select*
16	MASQ Inh*	Pilot Headset L
17	Nav 1 In	8 Ohm Select*
18	Nav 1 Return	Reserved
19	Nav 2 In	Tone Enable*
20	Nav 2 Return	Swap*
21	DME In (ADF 1 In)	Swap Return
22	DME Return (ADF 1 Return)	NC
23	Com 3 Spkr Load	Music 1 L In
24	Com 3 Spkr Load Return	Music 1 R In
25	Com 1 Spkr Load	Music 1 Return
26	Com 1 Spkr Load Return	Music 2 L In (NC)
27	Com 2 Spkr Load	Music 2 R In (DME In)
28	Com 2 Spkr Load Return	Music 2 Return (DME Return)
29	NC	FAILSAFE_WARN
30	Com 2 Key*	Com TX Mute*
31**	Alt Wrn In	Pilot Headset R
32**	Alt Wrn Return	Co-Pilot Mic In
33	Pilot Mic In	Co-Pilot Mic Key*
34	Pilot Mic Key*	Co-Pilot Mic Return
35	Pilot Mic Return	Pass 1 Mic
36	Ext White Lamp; A	Pass 1 Mic Return
37	Ext Blue Lamp; O	Pass 2 Mic
38	Ext Amber Lamp; M	Pass 2 Mic Return
39	Middle Mkr Sens	Pass 3 Mic
40	Pass Headset L	Pass 3 Mic Return

41	Pass Headset R	Pass 4 Mic
42	Pass Headset Return	Pass 4 Mic Return
43**	Tel Ringer Return	Spkr Return
44**	Tel Ringer In	Spkr Out

Table 2-1. J1 and J2 Pin Assignments (Dual ADF in Parentheses)

Connector Type		High Density	
Wire Gauge		22-28 AWG	
	Hand Crimping Tool	Positioner	Insertion/ Extraction Tool
Military P/N	M22520/2-01	M22520/2-09	M81969/1-04
Positronic	9507	9502-3	M81969/1-04
ITT Cannon	995-0001-584	995-0001-739	N/A
AMP	601966-1	601966-6	91067-1
Daniels	AFM8	K42	M24308/18-1
Astro	615717	615725	M81969/1-04

Table 2-2. Recommended Crimp Tools

NOTE

Non-Garmin part numbers shown are not maintained by Garmin and consequently are subject to change without notice.

2.5.2 Audio Shield Termination

The audio shield wires should be terminated at the rear of the unit to the screws between J1 and J2 as shown in figure 2-2.

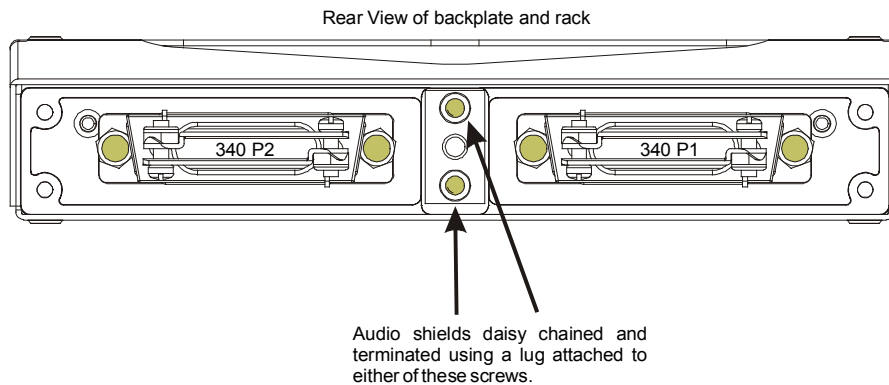

Figure 2-2. Audio Shield Termination

2.5.3 Noise

Because the audio panel is a point in the aircraft where signals from many pieces of equipment are brought together, care must be taken to minimize effects from coupled interference and ground loops.

Coupled interference can sneak into audio system interconnecting cables when they are routed near large AC electric fields, AC voltage sources, and pulse equipment (strobes, spark plugs, magnetos, EL displays, CRTs, etc). Interference can also couple into audio system interconnecting cables by magnetic induction when they are routed near large AC current-carrying conductors or switched DC equipment (heaters, solenoids, fans, autopilot servos, etc).

Ground loops are created when there is more than one path in which return currents can flow, or when signal returns share the same path as large currents from other equipment. These large currents create differences in ground potential between the various equipment operating in the aircraft. These differences in potential can produce an additive effect at an audio panel signal input.

The audio panel may “see” the desired input signal plus an unwanted component injected by ground differentials, a common cause of alternator-related noise. This is the main reason why all audio jacks should be isolated from ground. Terminating audio shields just at one end eliminates another potential ground loop injection point.

Single-point grounding cannot be overstressed for the various avionics producing and processing audio signals. Single-point, in this context, means that the various pieces of equipment share a single common ground connection back to the airframe. Good aircraft electrical/charging system ground bonding is also important.

The wiring diagrams and accompanying notes in this manual should be followed closely to minimize noise effects.

2.6 POST INSTALLATION CHECKOUT

CAUTION

Check wiring connections for errors before inserting the GMA 340 into the tray.
Incorrect wiring could cause internal component damage.

Except for marker beacon operation, an in-aircraft checkout may be performed in the aircraft on the ramp with known good microphone, headset, speaker and avionics receivers. Item numbers in parentheses refer to front panel controls shown in figure 3-1, page 3-1.

2.6.1 Lamp Test

Apply power to the unit by rotating the pilot intercom knob (5) clockwise.

The GMA 340 test button (17) checks the internal LED annunciators and marker beacon LEDs (1). Press TEST to confirm operation of the LEDs. Cover the photocell (19) with a finger and observe that the LED annunciators dim automatically. Check the front panel backlighting and dimming function. Each annunciation is illuminated.

2.6.2 Failsafe Operation Check

1. Turn the unit off by rotating the pilot intercom knob (5) counter clockwise.
2. Check the failsafe operation by exercising the COM 1 microphone, microphone key and audio over the headphones.

NOTE

For units without Mod 4 incorporated, if a monaural headset is plugged into a stereo jack the ring conductor will be shorted to the barrel conductor when the headset is plugged in preventing proper failsafe operation. No audio will be heard. In this type of installation, either a stereo/mono switch must be installed for proper operation or Mod 4 must be incorporated. If Mod 4 is incorporated, the audio will be heard only in the left channel of a stereo installation. See note 13 in figures B5 and B7 and refer to Garmin Service Bulletin 0209.

3. Turn the unit back on to continue testing.

2.6.3 Transceiver Operational Check

1. Perform a ramp test radio check by exercising the installed transceivers, microphone, microphone key and audio over the headphones and speaker.
2. Verify that communications are loud and clear and PTT operation is correct.

2.6.4 Intercom System (ICS) Check

NOTE

If a monaural headset is used in one position, no damage will occur if plugging into a stereo jack. In the case of passenger positions, any stereo listener will lose one channel when another passenger plugs in a mono headset.

1. Set the intercom to the ALL mode [Crew (9) and Pilot (10) LEDs off.]
2. Plug in headsets at each ICS position.

NOTE

For helicopter operation using a two-stage Intercom/PTT switch, prior to using the keyed-intercom mode, the VOX level should be set by adjusting the VOX knob while the first detent is actuated and held.

3. Adjust squelch (8) and volume (7) for each position and verify that the ICS is working properly.
4. Check Pilot and Copilot ICS positions for isolation and proper operation of volume and squelch controls (5, 6, 7 and 8).
5. Press the PA button (11). Verify that microphone audio is heard over the speaker.

2.6.5 Aircraft Receivers Check

1. Select the audio source corresponding to each installed avionics unit and check for audio over the headsets.
2. Check for Pilot/Copilot audio isolation when pressing the COM 1/2 button (15). (Not applicable to Dual ADF)
3. Press the SPKR button (12) and verify that any selected audio is heard over the speaker.

2.6.6 Music System Check

NOTE

Unit Mods 2 and 5 provide times ten gain for volume control of the entertainment music system. Unit Mod 5 provides either switching this function between unity gain (0 dB) and times ten gain (20 dB) or hard wiring J2 pin 15 to ground for times ten gain. When audio levels applied to Music 1 and Music 2 inputs are increased by 20 dB, the amplification may also increase unwanted audio noise. See note 17 in figures B5 and B7 and refer to Garmin Service Bulletins 0113 and 0210.

1. Set the intercom to the ALL mode [Crew (9) and Pilot (10) LEDs off.]
2. Connect a stereo audio source to MUSIC 1. Verify that stereo audio is heard over all headset positions.
3. Select an audio source to COM 1 (13) and verify that the sound is muted by active Com 1 audio (break squelch if necessary).
4. Connect a stereo music source to MUSIC 2. (NA to Dual ADF). Press the CREW button (9) to set the ICS to the crew mode. Verify that stereo audio is heard in the passenger headsets only.

CAUTION

Be sure to check all aircraft control movements before flight is attempted to insure that the wiring harness does not touch any moving part. Verify proper operation of the marker beacon during a flight test under VFR conditions.

This completes the in-aircraft post installation checkout. Perform a flight test after installing the unit to ensure satisfactory performance of the audio and marker beacon receiver functions. Verify proper operation of the marker lamps and marker audio, including the marker audio mute function. Check proper operation of the sensitivity selection [using the SENS button (4)] by flying towards the outer marker position initially using HI sensitivity. When the COM audio is just barely audible in the headset, switching to LO sensitivity should reduce or eliminate the audio.

2.7 ADJUSTMENTS

The following adjustments can be made through access holes in the top cover of the GMA 340:

1. Marker beacon audio level (Refer to Garmin Service Bulletin 0208 if connecting to a Sandel SN3308 EHSI.
2. Marker beacon sensitivity
3. Aircraft radio speaker output level
4. Pilot PA microphone speaker output level
5. Copilot PA microphone speaker output level
6. MUSIC 1 mute trip level

Refer to figure 2-3 for the location of the access holes.

CAUTION

Exercise care when inserting adjustment tools through the top cover. Damage to the unit may occur if an adjustment tool is accidentally forced against unintended components or circuit board paths. Use a 2 mm (max blade width) flat-blade non-conductive screw driver or adjustment tool.

CCW adjustment increases the marker audio level. CW adjustment increases the levels for the speaker outputs and MUSIC 1 mute.

For the marker beacon sensitivity adjustments, CW increases the sensitivity. The LOW sensitivity can be adjusted without affecting the HIGH sensitivity setting. However, adjusting the HIGH sensitivity setting will affect the LOW sensitivity setting also. If the HIGH sensitivity setting is adjusted, then the LOW sensitivity setting should be checked and adjusted afterwards, if needed. If your GMA 340 top cover does not have the marker beacon sensitivity adjustment access holes as indicated in figure 2-3, and you need to adjust the sensitivity, contact Garmin for instructions.

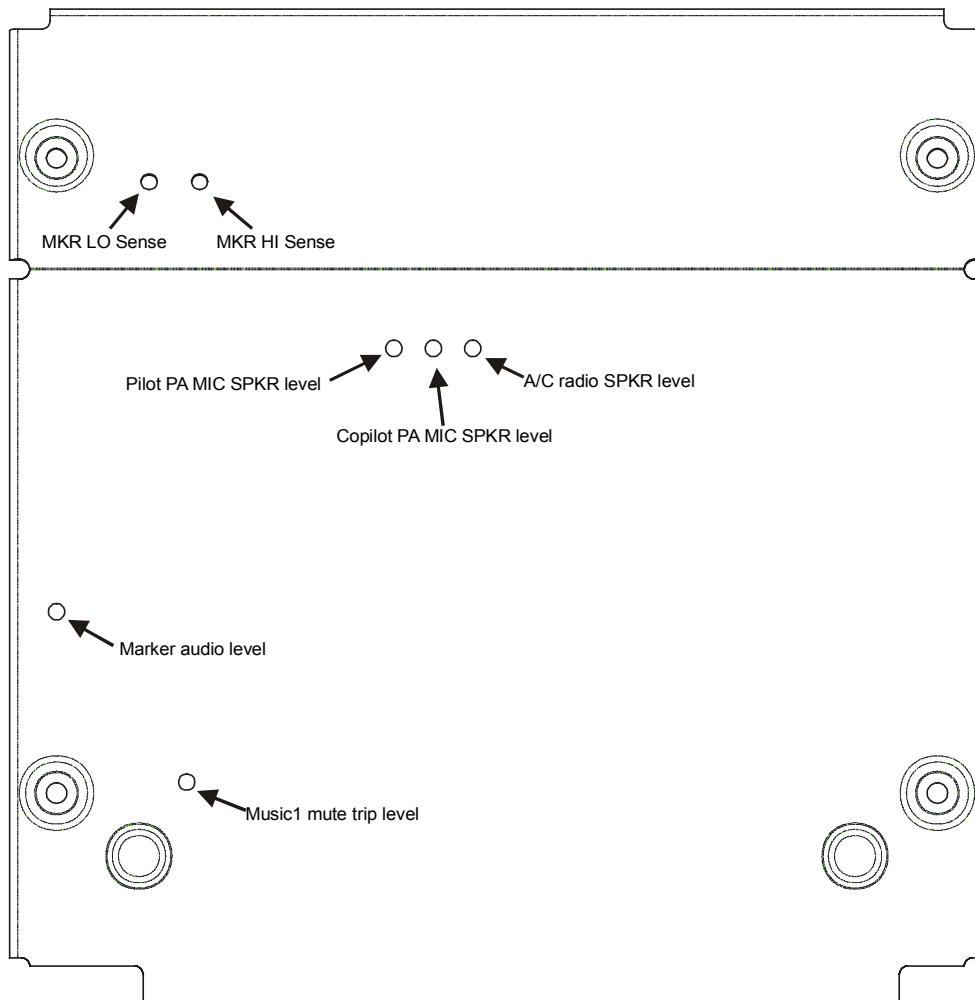

Figure 2-3. Access Hole Location (Top View)

SECTION 3

OPERATION

3.1 OPERATION

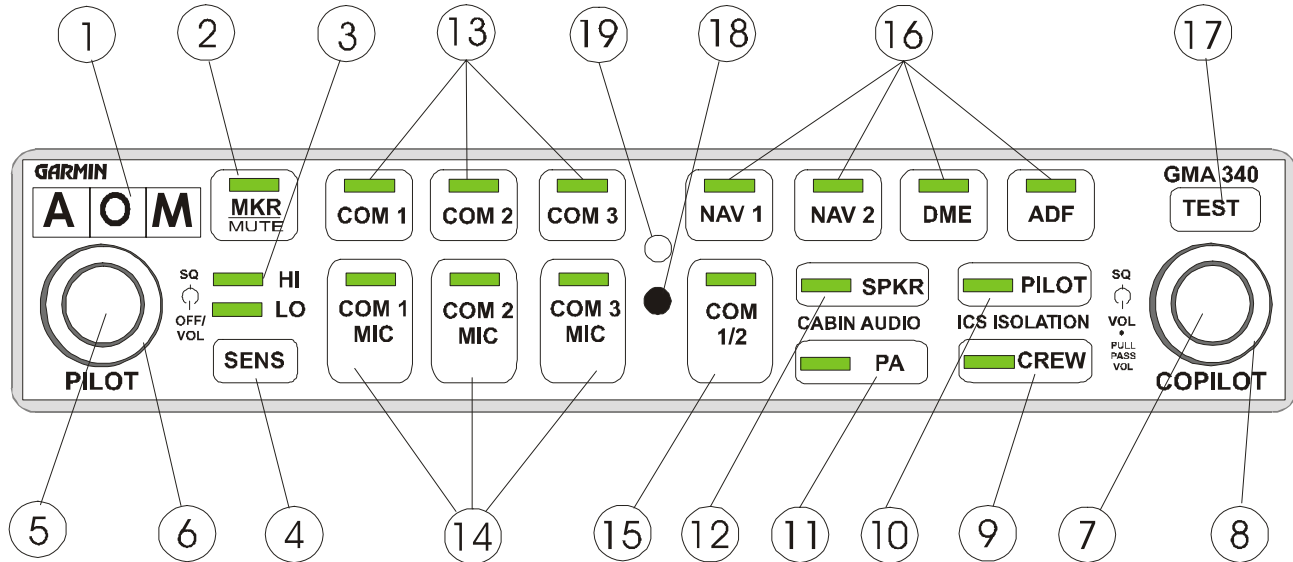

Figure 3-1. GMA 340 Front Panel

3.1.1 Front Panel Controls

1. Marker Beacon Lights
 2. Marker Beacon Receiver Audio Select/Mute Button
 3. Marker Beacon Receiver Sensitivity Indicator LEDs
 4. Marker Beacon Receiver Sensitivity Selection Button
-
5. Unit On/Off, Pilot Intercom System (ICS) Volume
 6. Pilot ICS Voice Activated (VOX) Intercom Squelch Level
 7. Copilot and Passenger ICS Volume Control (Pull out for Passenger Volume)
 8. Copilot and Passenger VOX Intercom Squelch Level
 9. Crew Isolation Intercom Mode Button
 10. Pilot Isolation Intercom Mode Button
-
11. Passenger Address (PA) Function Button
 12. Speaker Function Button (DME in Dual ADF)
-

-
13. Transceiver Audio Selector Buttons (COM 1, COM 2, COM 3)
 14. Transmitter (Audio/Mic) Selection Buttons
 15. Split COM Button (SPKR in Dual ADF)
 16. Aircraft Radio Audio Selection Buttons (NAV1, NAV2, DME, ADF)
-

17. Annunciator Test Button
18. Locking Screw Access
19. Photocell – Automatic Annunciator Dimming

3.1.2 On, Off, and Failsafe Operation

The GMA 340 is powered off when the left small knob (figure 3-1, item 5) is rotated fully CCW into the detent. To turn the unit on rotate the knob clockwise past the click. The knob then functions as the pilot's ICS volume control. A failsafe circuit connects the pilot's headset and microphone directly to COM 1 in case the power is interrupted or the unit is turned off. Refer to the note in paragraph 2.6.2.

3.1.3 Lighting

The intensity of the button annunciators and marker beacon LEDs are controlled automatically by a built-in photocell (19) on the front panel. Nomenclature backlighting is controlled by the aircraft dimmer bus. See installation wiring diagrams in Appendix B for guidance on connecting the dimmer bus to the GMA 340.

3.1.4 Transceivers

NOTE

Audio level is controlled by the selected com radio volume control.

Selection of either COM 1, COM 2, or COM 3 (13) for both MIC and audio source is accomplished by pressing either COM 1 MIC, COM 2 MIC, or COM 3 MIC (14). The active com audio is always heard on the headphones.

Each audio source can be selected independently by pressing COM 1, COM 2, or COM 3 (13). When selected in this way, they remain active as audio sources independently of which transceiver has been selected as the active microphone source.

When a microphone is keyed, the active transceiver's MIC button LED blinks approximately once per second to indicate the transmitter is active.

When no aircraft radio activity is detected by the GMA 340, the amount of ambient background noise from the radios is further reduced by the **MASQ**TM circuit. This processing is also applied to the Nav radios (described in 3.1.7). If this feature is not desired, then J1 pin 16 (MASQ INH*) should be tied to ground.

3.1.5 Split Com (Not Applicable to Dual ADF)

Pressing the COM 1/2 button (15) activates the split com function. While this mode is active, COM 2 is dedicated solely to the copilot as a MIC/audio source while COM 1 is dedicated to the pilot as a MIC/audio source. The pilot can still listen to COM 3, NAV 1, NAV 2, DME, ADF, and MKR. The pilot and copilot can simultaneously transmit in this mode, the pilot transmitting over COM 1 and the copilot transmitting over COM 2. The SPLIT COM mode is cancelled by pressing the COM 1/2 button a second time.

While in the split com mode the copilot may make PA announcements while the pilot continues using COM 1 independently. When the PA button is pressed after the split com mode is activated, the copilot's mic is output over the cabin speaker when keyed. A second press of the PA button returns the copilot to normal split com operation.

NOTE

If the com radios in the installation utilize a “transmit interlock” system, the split com function may require that this feature is enabled. Refer to the radio's installation manual for guidance. Garmin makes no expressed or implied guarantees regarding the suitability of the split com feature in a given installation.

3.1.6 Com Swap Function

The GMA 340 allows the use of a remote mounted switch (typically on the yoke) to alternately transfer the active microphone back and forth between COM 1 and COM 2. The remote switch should be a momentary type, connected between J2 pin 20 (SWAP*) and J2 pin 21 (SWAP return). Pressing the remote switch will have no affect if COM 3 is the active transceiver or when split com is in use.

3.1.7 Aircraft Radios & Navigation

NOTE

Audio level is controlled by the selected nav radio volume control.

Pressing NAV 1, NAV 2, DME, ADF (16), or MKR (2) (see MKR beacon operation) selects that audio source. A second button press deselects the audio source.

In addition, the GMA 340 provides inputs for an unswitched aircraft radio (TEL RINGER) and an unmuted, unswitched aircraft radio (ALT WRN).

3.1.8 Speaker Output

Pressing the SPKR button (12) selects Aircraft radios over the cabin speaker. The speaker output is muted when a COM microphone is keyed. Speaker level is adjustable through an access hole in the top of the unit (see figure 2-3).

3.1.9 PA Function

The PA mode is activated by pressing the PA button (11). Then, when either the pilot's or copilot's microphone is keyed, the corresponding mic audio is heard over the cabin speaker. If the SPKR button (12) is also active, then any selected speaker audio is muted while the microphone is keyed. The SPKR button does not have to be previously active in order to use the PA function. Pilot and copilot PA microphone speaker levels are adjustable through an access hole in the top of the unit (see figure 2-3).

3.1.10 Auxiliary Entertainment Inputs

The GMA 340 and 340H provide two stereo entertainment inputs: MUSIC 1 and MUSIC 2. The 340 Dual ADF has only MUSIC 1. MUSIC 1 is soft-muted during all aircraft radio activity and normally during ICS activity. MUSIC 2 is a non-muted input. These inputs are compatible with popular portable entertainment devices such as cassette tape or CD players. The headphone outputs of these devices are used and plugged into MUSIC 1 or MUSIC 2. Two 3.5 mm stereo phone jacks should be installed in a convenient location for this purpose. MUSIC 1 and MUSIC 2 have characteristics that are affected by the active intercom mode (see paragraph 3.1.11). Refer to the notes in paragraphs 2.6.2 and 2.6.6 for mono/stereo connections and music amplification.

3.1.11 Intercom System (ICS) (Pilot and Copilot functions are reversed on the 340H)

Intercom volume and squelch (VOX) are adjusted using the following front panel knobs (note that knobs are reversed in the 340H version):

- **LEFT SMALL KNOB**— Unit on/off power control and Pilot ICS volume (5). Full CCW DETENT position is OFF.
- **LEFT LARGE KNOB**— Pilot ICS mic VOX squelch level (6). CW rotation increases the amount of mic audio (VOX level) required to break squelch. Full CCW is the “hot mic” position.
- **RIGHT SMALL KNOB**— IN position: Copilot ICS volume. OUT position: Passenger ICS volume (7).
- **RIGHT LARGE KNOB**— Copilot and passenger mic VOX squelch level (8). CW rotation increases the amount of mic audio (VOX level) required to break squelch. Fully CCW is the “hot mic” position.

Each microphone input (six total) has a dedicated VOX circuit to ensure that only the active microphone(s) is/are heard when squelch is broken. This represents a vast improvement over single-gate systems and reduces the amount of background noise in the headphones during cockpit communications. After the operator has stopped talking, the intercom channel remains momentarily open to avoid closure between words or normal pauses.

The GMA 340 provides three intercom modes: PILOT, CREW and ALL. The mode selection is accomplished using the PILOT (10) and CREW (9) buttons.

Pressing a button activates the corresponding ICS mode. Pressing again deactivates the mode. The operator can switch directly from PILOT to CREW or from CREW to PILOT by pressing the other mode button. ALL mode is active when neither PILOT or CREW mode is selected. These modes allow different degrees of interaction between the crew and passengers:

- PILOT mode isolates the pilot from everyone else and dedicates the aircraft radios to the pilot exclusively. The copilot and passengers share communication between themselves but cannot communicate with the pilot or hear the aircraft radios.
- CREW mode places the pilot and copilot on a common ICS communication channel. The passengers are on their own intercom channel and can communicate with each other, but cannot communicate with the crew or hear the aircraft radios.
- ALL mode allows full intercom communication between everyone plugged in to the GMA 340. Aircraft radios are heard by all.
- MUSIC 1 and MUSIC 2 stereo entertainment inputs are affected by the intercom mode selected.

The following table summarizes the ICS operation for the different modes supported by the GMA 340.

MODE	PILOT HEARS	COPILOT HEARS	PASSENGER HEARS	MUSIC 1 MUTING TRIGGERED BY
PILOT (LED LIT)	Selected Radios. Pilot.	Copilot. Passengers. MUSIC 1.	Passengers. Copilot. MUSIC 1.	Copilot or passenger ICS activity.
CREW (LED LIT)	Selected Radios. Pilot. Copilot. MUSIC 1.	Selected Radios. Copilot. Pilot. MUSIC 1.	Passengers. MUSIC 2. (MUSIC 1 in Dual ADF)	Aircraft radio activity. MKR activity. Pilot or Copilot ICS activity.
ALL (LEDs OFF)	Selected Radios. Pilot. Copilot. Passengers. MUSIC 1.	Selected Radios. Pilot. Copilot. Passengers. MUSIC 1.	Selected Radios. Pilot. Copilot. Passengers. MUSIC 1.	Aircraft radio activity. MKR activity. ICS activity.

MUSIC 1 is normally muted during ICS activity. However an installation option is available to disable ICS MUTE. When ICS MUTE INHIBIT* (J2 pin 13) is connected to ICS MUTE INHIBIT RETURN (J2 pin 14), muting of MUSIC 1 will not occur due to ICS activity. The MUSIC 1 mute trip level is adjustable through an access hole in the top of the unit (see figure 2-3).

3.1.12 Mono/Stereo Headset

The use of stereo headsets is highly recommended. If monaural headsets are plugged into stereo jacks that do not have a switch installed the unit will not be damaged.



Use of a monaural headset in a stereo jack shorts the right headset channel output to ground. A person listening on a monaural headset will hear only the left channel from the GMA 340 in both ears. If a monaural headset is used at one of the passenger positions, any other passenger listening on a stereo headset will hear audio in their left ear only, unless their headset has a stereo/mono switch and it is set for mono.

In units without Mod 4 incorporated, if the pilot uses a monaural headset in a stereo jack, no audio will be heard during failsafe operation. When using a monaural headset the pilot's jack must be equipped with a stereo/mono switch and it must be set to the 'mono' position for proper failsafe operation. If Mod 4 is incorporated, and the pilot uses a stereo headset in a stereo jack, audio will be heard in the left channel only during failsafe operation.

3.1.13 Marker Beacon Receiver

The marker beacon is part of an ILS system, and in certain instances, used to identify an airway. In addition to the normal marker beacon functions, the GMA 340 provides an audio muting function. The LEDs illuminate, and an associated keyed-tone is heard (when MKR audio is selected), when the aircraft passes over a 75 MHz marker beacon transmitter.

The lights and audio keying for ILS approach operation are summarized below.

Audio Frequency	Audio Keying	LED Actuated
400 Hz		Blue (Outer)
1300 Hz		Amber (Middle)
3000 Hz		White (Airway/Inner)

The marker beacon audio level is aligned at the factory to produce its rated audio output. However, the output level is adjustable through an access hole in the top cover of the unit (see figure 2-3).

The GMA 340's marker beacon receiver controls are located on the left side of the front panel [(1) through (4)]. The SENS button (4) selects either high or low sensitivity as indicated by the HI or LO LED being lit. Low sensitivity is used on ILS approaches while high sensitivity allows operation over airway markers or to get an earlier indication of nearing the outer marker during an approach.

The marker audio is selected initially by pressing the MKR/mute button (2). If no marker beacon signal is received, then pressing again will deselect the marker audio. This operation is similar to selecting any other audio source on the GMA 340. However, if the second button press occurs while a marker beacon signal is received, then the marker audio is muted but not deselected. The button's LED will remain lit to indicate that the source is still selected.

The GMA 340's **SmartMute**TM function then monitors the marker signal and automatically unmutes the audio when the current marker signal is no longer being received.

In all cases, the marker beacon LEDs operate independently of any audio selection and cannot be turned off. The GMA 340 can drive external marker lamps if required. Maximum source current is 125 mA (8 Vdc max).

APPENDIX A

CERTIFICATION DOCUMENTS

A.1 CONTINUED AIRWORTHINESS

This section provides assistance to the installing agency in preparing Instructions for Continued Airworthiness (ICA) in response to Bulletin Number HBAW 98-18, "Checklist for Instructions for Continued Airworthiness for Major Alterations Approved Under the Field Approval Process", effective 10/7/98.

Aviation Authority approved installers are hereby granted permission to reference appropriate service instructions and excerpts from this Installation Manual to accomplish the Instructions for Continued Airworthiness. This permission does not construe suitability of the documents. It is the applicant's responsibility to determine the suitability of the documents for the ICA.

Following is suggested ICA for a Garmin GMA 340 Audio Panel installation. Some of the checklist items do not apply, in which case they should be marked "N/A" (Not Applicable). In this sample, square braces are used to indicate instances where explicit words should be substituted.

INSTRUCTIONS FOR CONTINUED AIRWORTHINESS, GARMIN GMA 340 AUDIO PANEL

1. Introduction

[Aircraft that has been altered: Registration (N-) number, Make, Model and Serial Number]

Content, Scope,

Purpose and Arrangement: This document identifies the Instructions for Continued Airworthiness for the modification of the above aircraft by installation of a Garmin GMA 340 Audio Panel.

Applicability: Applies to aircraft altered by installation of the Garmin GMA 340 Audio Panel.

Definitions/Abbreviations: None, N/A.

Precautions: None, N/A.

Units of Measurement: None, N/A.

Referenced Publications: Garmin GMA 340 Audio Panel Installation Manual,
P/N 190-00149-01
Garmin GMA 340 Audio Panel Maintenance Manual,
P/N 190-00149-02
Garmin GMA 340 Audio Panel Pilot's Guide,
P/N 190-00149-00.
Garmin GMA 340 STC #SA00710WI

Distribution: This document should be a permanent aircraft record.

2. Description of the Alteration

Installation of the Garmin GMA 340 Audio Panel, with interface to external transceivers and [include other equipment/systems as appropriate]. Refer to section 2 and interconnect wiring diagrams figures B3 through B6 of this manual for interconnect information. Antenna installation, removal and replacement should be in accordance with applicable provisions of AC43.13-1B and 43.13-2A.

3. Control, Operation Information

Refer to the GMA 340 Audio Panel Pilot's Guide.

4. Servicing Information

N/A

5. Maintenance Instructions

Maintenance of the GMA 340 Audio Panel is 'on condition' only. Periodic maintenance is not required. Refer to the GMA 340 Audio Panel Maintenance Manual.

6. Troubleshooting Information

Refer to the GMA 340 Audio Panel Maintenance Manual.

7. Removal and Replacement Information

Refer to section 2.4 of this manual. If the unit is removed and reinstalled, a functional check of the equipment should be conducted in accordance with section 3 of this manual.

8. Diagrams

Refer to Appendix B of this manual.

9. Special Inspection Requirements

N/A

10. Application of Protective Treatments

N/A

11. Data: Relative to Structural Fasteners

Antenna installation, removal and replacement should be in accordance with applicable provisions of AC43.13-1A and 43.13-2A.

12. Special Tools

N/A

13. This Section is for Commuter Category Aircraft Only

A. Electrical loads: Refer to section 1.3 of this manual.

B. Methods of balancing flight controls: N/A.

C. Identification of primary and secondary structures: N/A.

D. Special repair methods applicable to the airplane: Antenna installation, removal, and replacement should be in

accordance with applicable provisions of AC43.13-1B and 43.13-2A.

14. Overhaul Period

No additional overhaul time limitations.

15. Airworthiness Limitation Section

N/A

16. Revision

To revise this ICA, a letter must be submitted to the local FSDO with a copy of the revised FAA Form 337, and revised ICA. The FAA inspector accepts the change by signing Block 3 and including the following statement:

“The attached revised/new Instructions for Continued Airworthiness (date _____) for the above aircraft or component major alteration have been accepted by the FAA, superseding the Instructions for Continued Airworthiness (date _____).”

17. Assistance

Flight Standards Inspectors have the resources to respond to questions regarding the ICA.

18. Implementation and Record Keeping

For major alterations performed in accordance with FAA field approval policy, the owner/operator operating under Part 91 is responsible for ensuring that the ICA is made part of the applicable section 91.409 inspection program for their aircraft. This is accomplished when a maintenance entry is made in the aircraft’s maintenance record in accordance with section 43.9. This entry records the major alteration and identifies the original ICA location (e.g., Block 8 of FAA Form 337, dated _____) along with a statement that the ICA is now part of the aircraft’s inspection/maintenance requirements.

A.2 ENVIRONMENTAL QUALIFICATION FORM

NOMENCLATURE: GMA 340 Audio Panel

TYPE/MODEL/ PART NO.: 010-00152-(), which includes all 011-00401-(); 340H is -01; Dual ADF is-20.
TSO-C50c, TSO-C35d Class A, JTSO-C50c, JTSO-2C35d

MANUFACTURER'S SPECIFICATION AND/OR OTHER APPLICABLE SPECIFICATION: 004-00054-00

MANUFACTURER: Garmin International

ADDRESS: 1200 E. 151st St., Olathe, Kansas 66062

CONDITIONS	SECTION	DESCRIPTION OF CONDUCTED TESTS
Temperature and Altitude	4.0	Equipment tested to Category A1D1 except as noted
Low Temperature	4.5.1	
High Temperature	4.5.2, 4.5.3	
In-flight Loss of Cooling	4.5.4	Cooling air not required
Altitude	4.6.1	
Decompression	4.6.2	
Overpressure	4.6.3	
Temperature variation	5.0	Equipment tested to Category C
Humidity	6.0	Equipment tested to Category A
Shock	7.0	Equipment tested per DO-160C, Par. 7.2.1
Operational	7.2	Equipment tested per DO-160C, Par. 7.2.1
Crash Safety	7.3	Equipment tested per DO-160C, Par. 7.2.1
Vibration	8.0	Equipment tested without shock mounts to Categories B, M, and N
Explosion	9.0	Equipment identified as Category X, no test required
Waterproofness	10.0	Equipment identified as Category X, no test required
Fluids Susceptibility	11.0	Equipment identified as Category X, no test required
Sand and Dust	12.0	Equipment identified as Category X, no test required
Fungus	13.0	Equipment identified as Category X, no test required
Salt Spray	14.0	Equipment identified as Category X, no test required
Magnetic Effect	15.0	Equipment tested is class Z
Power Input	16.0	Equipment tested to Category B
Voltage Spike	17.0	Equipment tested to Category A
Audio Frequency Susceptibility	18.0	Equipment tested to Category B
Induced Signal Susceptibility	19.0	Equipment tested to Category A
Radio Frequency Susceptibility	20.0	Equipment tested to Category T *
Radio Frequency Emission	21.0	Equipment tested to Category B
Lightning Induced Transient Susceptibility	22.0	Equipment identified as Category XXXX, no test required
Lightning Direct Effects Test	23.0	Equipment identified as Category X, no test required
Icing	24.0	Equipment identified as Category X, no test required
Other Tests:		
Remarks:	* Using 2V/m	

APPENDIX B

INSTALLATION DRAWINGS

B.1 GENERAL

This section contains the following installation drawings:

- B1, GMA 340 Outline Drawing
- B2, Connector/Rack Kit Drawing
- B3, GMA 340 Recommended Panel Cutout Dimensions
- B4, J1 Interconnect Wiring Diagram
- B5, J2 Interconnect Wiring Diagram
- B6, J1 Interconnect Wiring Diagram
- B7, J2 Interconnect Wiring Diagram

This page intentionally left blank

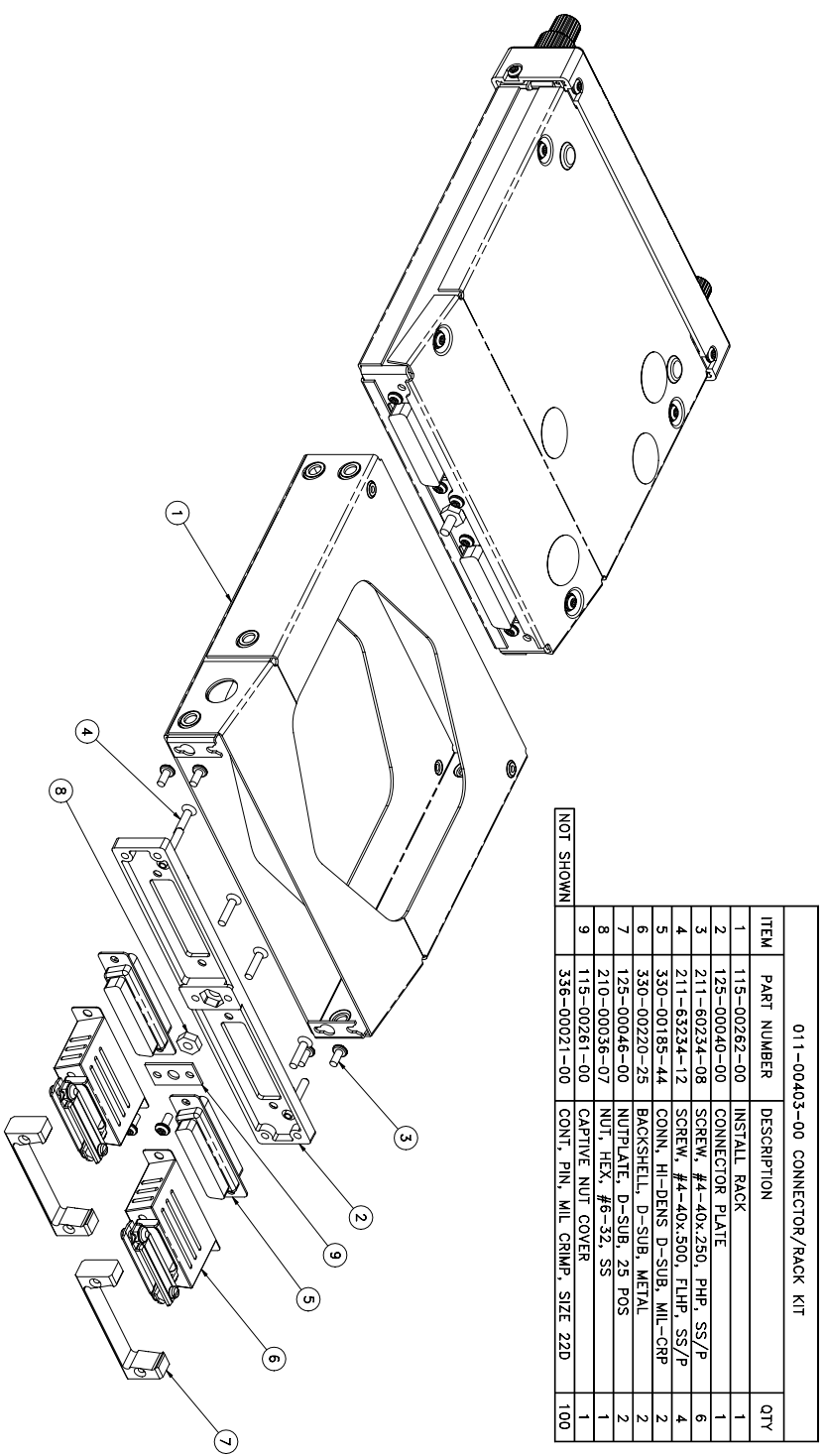

011-00403-00 CONNECTOR/RACK KIT			
ITEM	PART NUMBER	DESCRIPTION	QTY
1	115-00262-00	INSTALL RACK	1
2	125-00040-00	CONNECTOR PLATE	1
3	211-60234-08	SCREW, #4-40X.250, PHP, SS/P	6
4	211-63234-12	SCREW, #4-40X.500, FLHP, SS/P	4
5	330-00185-44	CONN, HI-DENS D-SUB, MIL-CRP	2
6	330-00220-25	BACKSHELL, D-SUB, METAL	2
7	125-00046-00	NUPLATE, D-SUB, 25 POS	2
8	210-00036-07	NUIT, HEX, #6-32, SS	1
9	115-00261-00	CAPTIVE NUT COVER	1
NOT SHOWN			100
	336-00021-00	CONT, PIN, MIL CRIMP, SIZE 22D	1

Figure B2. CONNECTOR/RACK KIT DRAWING

OPTION 1:
 STACK CUTOUT (RACK INSTALLED
 FROM FRONT OF AIRCRAFT PANEL)

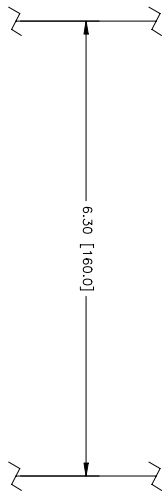

OPTION 2:
 RADIO CUTOUT (RACK INSTALLED
 FROM FRONT OF AIRCRAFT PANEL)

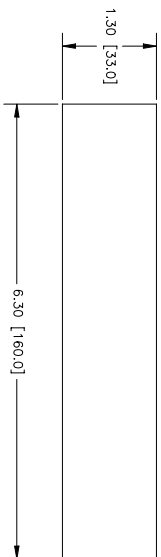

OPTION 3:
 RADIO CUTOUT (RACK INSTALLED
 FROM BACK OF AIRCRAFT PANEL ONLY)
 MAXIMUM AIRCRAFT PANEL THICKNESS
 IS .125 INCH [3.2 mm]

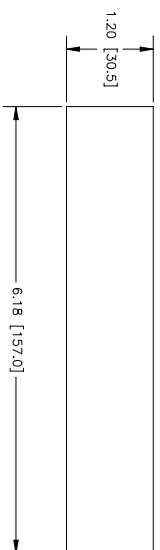

- NOTES:
1. DIMENSIONS: INCH [mm].
 2. IF THE FRONT LIP OF THE MOUNTING RACK IS BEHIND THE SURFACE OF THE AIRCRAFT PANEL, THE UNIT CONNECTORS MAY NOT FULLY ENGAGE.

Figure B3. GMA 340 RECOMMENDED PANEL CUTOUT DIMENSIONS

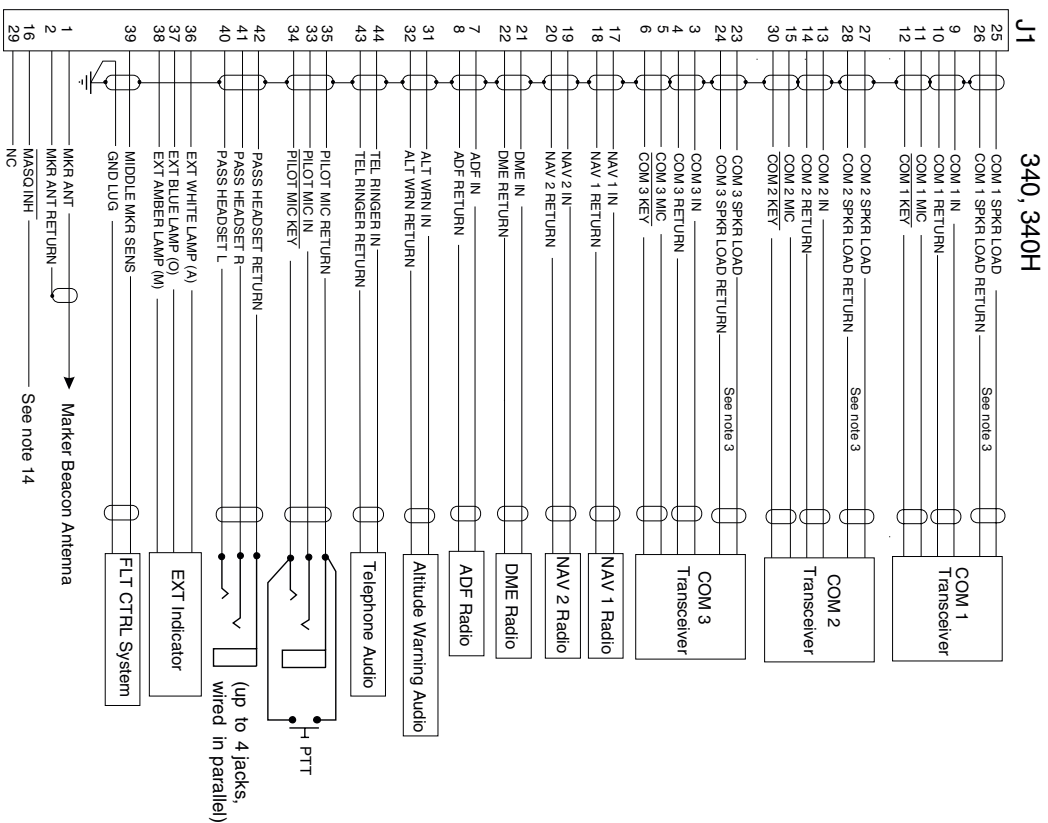

Figure B4. J1 INTERCONNECT WIRING DIAGRAM

NOTES PERTAINING TO J1 AND J2

- UNLESS OTHERWISE INDICATED, ALL SHIELDS MUST BE TERMINATED AT THE GMA 340 END ONLY.
- ALL WIRE SIZE SHOULD BE AWG 24 OR LARGER, TEFLON INSULATED, EXCEPT FOR THE FOLLOWING:
J2 PINS 8, 9, 10, 11 (AWG 22, TEFLON INSULATED)
J2 PINS 43, 44 (AWG 22, TEFLON INSULATED)
- SOME COMMUNICATION TRANSCIEVERS REQUIRE THEIR SPEAKER OUTPUT TO BE LOADED FOR PROPER OPERATION. THE GMA 340 PROVIDES INTERNAL DUMMY LOADS FOR THIS PURPOSE. CONNECT ONLY IF REQUIRED. REFER TO TRANSCIEVER DOCUMENTATION.
- CONNECT LIGHTING BUS AS SHOWN IN THE FOLLOWING TABLE:

VOLTAGE	HIGH SIDE OF BUS	LOW SIDE OF BUS
28V LIGHTING	J2 PIN 7	J2 PINS 5 AND 6
14V LIGHTING	J2 PINS 6 AND 7	J2 PIN 5

- ALL HEADSET, MICROPHONE, AND MUSIC PHONE PLUGS MUST BE ELECTRICALLY ISOLATED FROM GROUND. THIS MAY REQUIRE THE USE OF INSULATING WASHERS WHEN MOUNTING THE PHONE PLUGS. ADDITIONALLY, THE SPEAKER RETURN MUST BE ISOLATED FROM GROUND.
- PA MUTE IS AN OUTPUT FROM THE GMA 340 THAT IS PULLED LOW WHEN ACTIVE. IT IS USED TO TRIGGER THE MUTE FUNCTION ON AN EXTERNAL PA SYSTEM.
- NORMALLY, ANY ICS (INTERCOM) ACTIVITY WILL CAUSE THE MUSIC 1 SOURCE TO BE MUTED. IF THIS IS NOT DESIRED, THEN J2 PIN 13 MUST BE CONNECTED TO J2 PIN 14, EITHER PERMANENTLY, OR VIA A SWITCH.
- J2 PIN 17 (8 OHM SELECT*) IS ONLY FOR USE IN INSTALLATIONS WHERE AN 8 OHM CABIN SPEAKER IS INSTALLED. THE FUNCTION ALLOWS THE SAME POWER TO BE DELIVERED TO AN 8 OHM SPEAKER AS WOULD NORMALLY BE DELIVERED TO A 4 OHM SPEAKER. IF AN 8 OHM SPEAKER IS USED AND THE SPEAKER VOLUME IS ACCEPTABLE, THEN THIS PIN SHOULD BE LEFT OPEN. IF AN 8 OHM CABIN SPEAKER IS USED, BUT MORE SPEAKER VOLUME IS DESIRED, THEN J2 PIN 17 MUST BE TIED TO GROUND AND THE SPEAKER VOLUME SHOULD BE READJUSTED. DO NOT GROUND J2 PIN 17 IN A 4 OHM CABIN SPEAKER INSTALLATION.
- J2 PIN 19 (TONE ENABLE*) CAN BE LEFT OPEN OR TIED TO GROUND. IF TIED TO GROUND, THEN A SHORT AUDIBLE TONE WILL BE HEARD IN THE PILOT AND COPILOT HEADSETS EACH TIME A BUTTON IS PRESSED. IF LEFT OPEN, NO TONE IS HEARD.
- USE COAX MEETING THE APPLICABLE AVIATION REGULATION FOR THE MARKER BEACON ANTENNA CABLE. WHEN ROUTING THE MARKER BEACON ANTENNA CABLE, AVOID SHARP CORNERS AND ROUTE AWAY FROM HIGH CURRENT WIRING AND ANY TRANSMITTER ANTENNA CABLES.
- PINS 31 AND 32 OF J1 ARE UNSWITCHED, UNMUTED INPUTS. PINS 43 AND 44 OF J1 ARE UNSWITCHED INPUTS.
- J2 PINS 10 AND 11 SHOULD BE CONNECTED DIRECTLY TO THE AIRFRAME USING MINIMUM WIRE LENGTH.

340, 340H

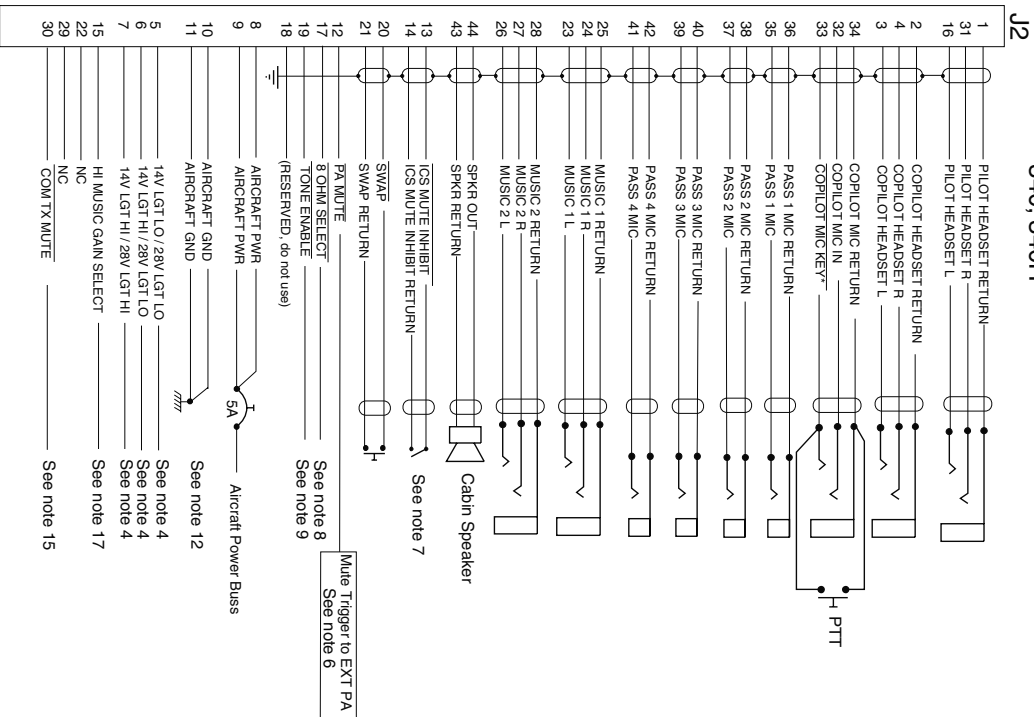

NOTES PERTAINING TO J1 AND J2 (Cont'd)
 NOTE 13A APPLIES TO GMA 340 UNITS WITHOUT MOD 4.

- 13A. IF GENERAL AVIATION MONOPHONIC HEADSETS HAVING TRUE MONOPHONIC PLUGS ARE USED IN AN INSTALLATION HAVING STEREO HEADPHONE JACKS, THE RING CONDUCTOR WILL BE SHORTED TO THE BARREL CONDUCTOR WHEN THE HEADSET IS PLUGGED IN. THIS WILL NOT DAMAGE THE GMA 340. HOWEVER, THIS WILL PREVENT PROPER FAILSAFE OPERATION. ADDITIONALLY, SINCE THE PASSENGER HEADSETS ARE CONNECTED IN PARALLEL, ALL PASSENGERS WILL LOSE ONE CHANNEL IF A MONO HEADSET IS PLUGGED INTO A PASSENGER POSITION. TO AVOID THIS, STEREO/MONO SWITCHES MAY BE INSTALLED AS SHOWN BELOW. WHEN A MONO HEADSET IS USED, THE SWITCH MUST BE SET TO THE OPEN POSITION.

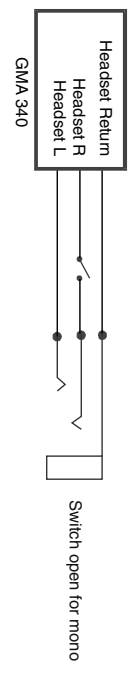

NOTE 13B APPLIES TO GMA 340 UNITS WITH MOD 4.

- 13B. IF UNIT MOD 4 IS INCORPORATED, THE ABOVE CONDITIONS STILL REMAIN EXCEPT THAT MOD 4 ENSURES PROPER FAILSAFE OPERATION FOR BOTH STEREO AND MONO HEADSETS WITHOUT REQUIRING A STEREO/MONO SWITCH.
- 14. WHEN NO AIRCRAFT RADIO ACTIVITY IS DETECTED BY THE GMA 340, THE AMOUNT OF AMBIENT BACKGROUND NOISE FROM THE RADIOS IS FURTHER REDUCED BY THE MASQ CIRCUIT. IF THIS FUNCTION IS NOT DESIRED, THEN J1 PIN 16, MASQ INH SHOULD BE TIED TO GROUND. THIS NOTE DOES NOT APPLY TO THE FOLLOWING GMA 340 SERIAL NUMBERS: 94900000 TO 94900499 AND 96250000 TO 96250399.
- 15. THIS NOTE APPLIES ONLY TO UNITS CONFORMING TO MOD LEVEL 1. NORMAL MODE: WHEN THIS PIN IS TIED TO GROUND, TRANSMITTING (KEYING) ON ANY COM WILL CAUSE THE OTHER TWO COM AUDIOS TO BE MUTED DURING THE TRANSMIT. SPLIT COM MODE: WHEN THIS PIN IS TIED TO GROUND, NEITHER COM 1 AUDIO NOR COM 2 AUDIO WILL BE MUTED DURING ANY TRANSMIT. COM 3 AUDIO WILL ONLY BE MUTED WHEN THE PILOT TRANSMITS.
- 16. 2 STAGE MOMENTARY SWITCH. FIRST DETENT: KEYED INTERCOM. SECOND DETENT: MICROPHONE AUDIO AND PTT ACTIVE. PROVIDES KEYED INTERCOM IN HIGH NOISE ENVIRONMENTS.



- 17. CONNECT TO GROUND FOR TIMES TEN (20 DB) GAIN, OR INSTALL SWITCH TO SELECT BETWEEN UNITY GAIN (0 DB) AND TIMES TEN GAIN (20 DB) FOR MUSIC1 AND MUSIC2. THIS FUNCTION APPLIES ONLY TO UNITS WITH MOD 5 INCORPORATED.

Figure B5. J2 INTERCONNECT WIRING DIAGRAM

340 DUAL ADF

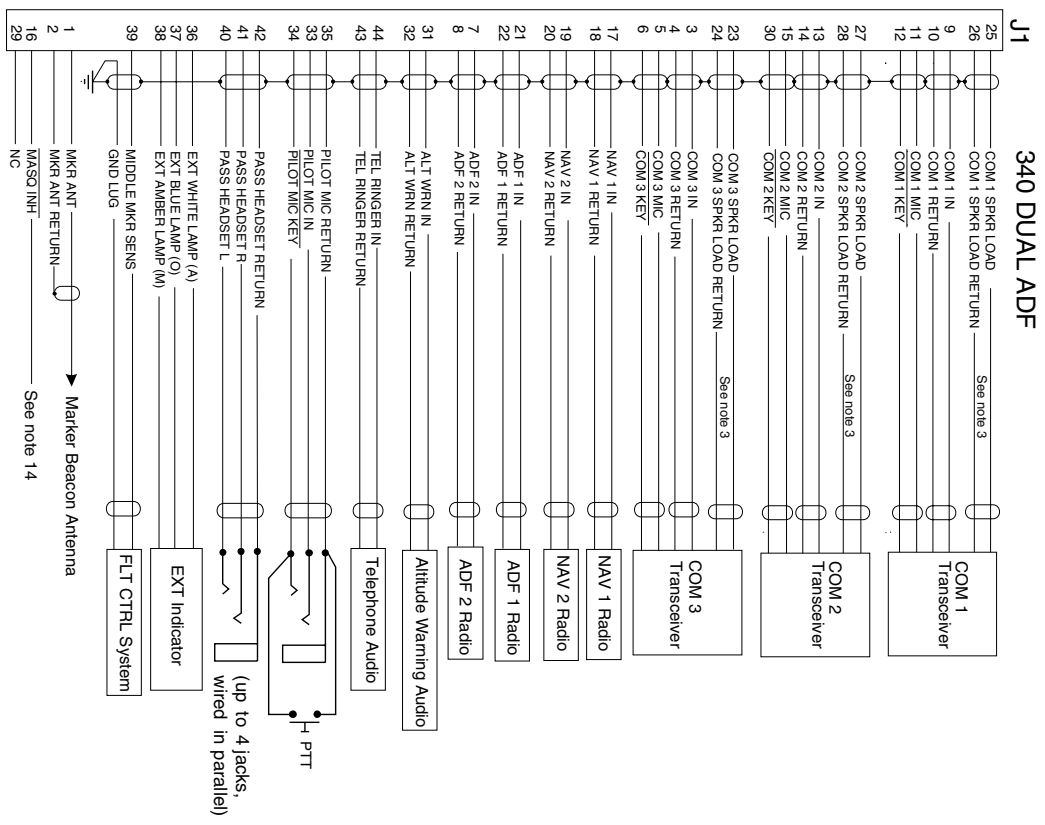

NOTES PERTAINING TO J1 AND J2

- UNLESS OTHERWISE INDICATED, ALL SHIELDS MUST BE TERMINATED AT THE GMA 340 END ONLY.
- ALL WIRE SIZE SHOULD BE AWG 24 OR LARGER, TEFLON INSULATED, EXCEPT FOR THE FOLLOWING:
 J2 PINS 8, 9, 10, 11 (AWG 22, TEFLON INSULATED)
 J2 PINS 43, 44 (AWG 22, TEFLON INSULATED)
- SOME COMMUNICATION TRANSCIEVERS REQUIRE THEIR SPEAKER OUTPUT TO BE LOADED FOR PROPER OPERATION. THE GMA 340 PROVIDES INTERNAL DUMMY LOADS FOR THIS PURPOSE. CONNECT ONLY IF REQUIRED. REFER TO TRANSCIEVER DOCUMENTATION.
- CONNECT LIGHTING BUS AS SHOWN IN THE FOLLOWING TABLE:

VOLTAGE	HIGH SIDE OF BUS	LOW SIDE OF BUS
28V LIGHTING	J2 PIN 7	J2 PINS 5 AND 6
14V LIGHTING	J2 PINS 6 AND 7	J2 PIN 5

- ALL HEADSET, MICROPHONE, AND MUSIC PHONE PLUGS MUST BE ELECTRICALLY ISOLATED FROM GROUND. THIS MAY REQUIRE THE USE OF INSULATING WASHERS WHEN MOUNTING THE PHONE PLUGS. ADDITIONALLY, THE SPEAKER RETURN MUST BE ISOLATED FROM GROUND.
- PA MUTE IS AN OUTPUT FROM THE GMA 340 THAT IS PULLED LOW WHEN ACTIVE. IT IS USED TO TRIGGER THE MUTE FUNCTION ON AN EXTERNAL PA SYSTEM.
- NORMALLY, ANY ICS (INTERCOM) ACTIVITY WILL CAUSE THE MUSIC SOURCE TO BE MUTED. IF THIS IS NOT DESIRED, THEN J2 PIN 13 MUST BE CONNECTED TO J2 PIN 14, EITHER PERMANENTLY, OR VIA A SWITCH.
- J2 PIN 17 (8 OHM SELECT*) IS ONLY FOR USE IN INSTALLATIONS WHERE AN 8 OHM CABIN SPEAKER IS INSTALLED. THE FUNCTION ALLOWS THE SAME POWER TO BE DELIVERED TO AN 8 OHM SPEAKER AS WOULD NORMALLY BE DELIVERED TO A 4 OHM SPEAKER. IF AN 8 OHM SPEAKER IS USED AND THE SPEAKER VOLUME IS ACCEPTABLE, THEN THIS PIN SHOULD BE LEFT OPEN. IF AN 8 OHM CABIN SPEAKER IS USED, BUT MORE SPEAKER VOLUME IS DESIRED, THEN J2 PIN 17 MUST BE TIED TO GROUND AND THE SPEAKER VOLUME SHOULD BE READJUSTED. DO NOT GROUND J2 PIN 17 IN A 4 OHM CABIN SPEAKER INSTALLATION.
- J2 PIN 19 (TONE ENABLE*) CAN BE LEFT OPEN OR TIED TO GROUND. IF TIED TO GROUND, THEN A SHORT AUDIBLE TONE WILL BE HEARD IN THE PILOT AND COPLOT HEADSETS EACH TIME A BUTTON IS PRESSED. IF LEFT OPEN, NO TONE IS HEARD.
- USE COAX MEETING THE APPLICABLE AVIATION REGULATION FOR THE MARKER BEACON ANTENNA CABLE. WHEN ROUTING THE MARKER BEACON ANTENNA CABLE, AVOID SHARP CORNERS AND ROUTE AWAY FROM HIGH CURRENT WIRING AND ANY TRANSMITTER ANTENNA CABLES.
- PINS 31 AND 32 OF J1 ARE UNSWITCHED. UNMUTED INPUTS. PINS 43 AND 44 OF J1 ARE UNSWITCHED INPUTS.
- J2 PINS 10 AND 11 SHOULD BE CONNECTED DIRECTLY TO THE AIRFRAME USING MINIMUM WIRE LENGTH.

Figure B6. J1 INTERCONNECT WIRING DIAGRAM

340 DUAL ADF

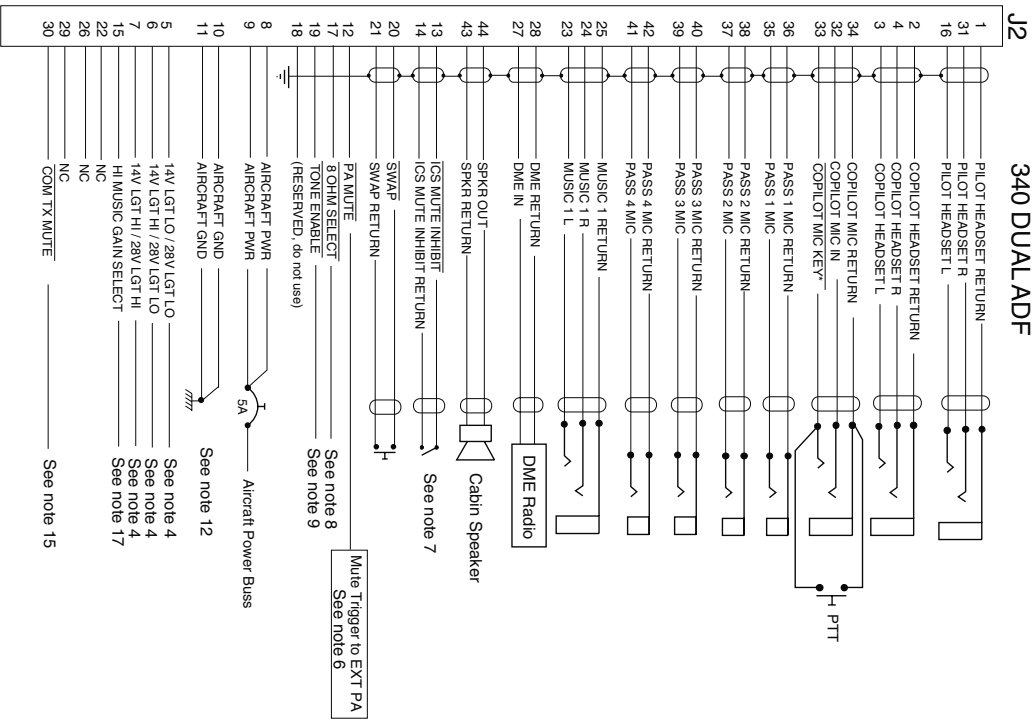

NOTES PERTAINING TO J1 AND J2 (Cont'd)
NOTE 13A APPLIES TO GMA 340 UNITS WITHOUT MOD 4.

- 13A. IF GENERAL AVIATION MONOPHONIC HEADSETS HAVING TRUE MONOPHONIC PLUGS ARE USED IN AN INSTALLATION HAVING STEREO HEADPHONE JACKS, THE RING CONDUCTOR WILL BE SHORTED TO THE BARREL CONDUCTOR WHEN THE HEADSET IS PLUGGED IN. THIS WILL NOT DAMAGE THE GMA 340. HOWEVER, THIS WILL PREVENT PROPER FALLSAFE OPERATION. ADDITIONALLY, SINCE THE PASSENGER HEADSETS ARE CONNECTED IN PARALLEL, ALL PASSENGERS WILL LOSE ONE CHANNEL IF A MONO HEADSET IS PLUGGED INTO A PASSENGER POSITION. TO AVOID THIS, STEREO/MONO SWITCHES MAY BE INSTALLED AS SHOWN BELOW. WHEN A MONO HEADSET IS USED, THE SWITCH MUST BE SET TO THE OPEN POSITION.

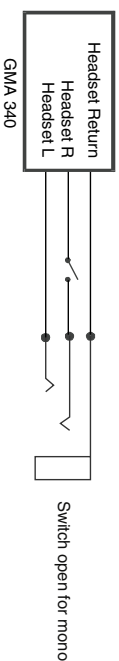

NOTE 13B APPLIES TO GMA 340 UNITS WITH MOD 4.

- 13B. IF UNIT MOD 4 IS INCORPORATED, THE ABOVE CONDITIONS STILL REMAIN EXCEPT THAT MOD 4 ENSURES PROPER FALLSAFE OPERATION FOR BOTH STEREO AND MONO HEADSETS WITHOUT REQUIRING A STEREO/MONO SWITCH.
14. WHEN NO AIRCRAFT RADIO ACTIVITY IS DETECTED BY THE GMA 340, THE AMOUNT OF AMBIENT BACKGROUND NOISE FROM THE RADIOS IS FURTHER REDUCED BY THE MASQ CIRCUIT. IF THIS FUNCTION IS NOT DESIRED, THEN J1 PIN 16, MASQ INH SHOULD BE TIED TO GROUND. THIS NOTE DOES NOT APPLY TO THE FOLLOWING GMA 340 SERIAL NUMBERS: 94900000 TO 94900499 AND 96250000 TO 96250399.
15. THIS NOTE APPLIES ONLY TO UNITS CONFORMING TO MOD LEVEL 1. NORMAL MODE: WHEN THIS PIN IS TIED TO GROUND, TRANSMITTING (KEYING) ON ANY COM WILL CAUSE THE OTHER TWO COM AUDIOS TO BE MUTED DURING THE TRANSMIT. SPLIT COM MODE: WHEN THIS PIN IS TIED TO GROUND, NEITHER COM 1 AUDIO NOR COM 2 AUDIO WILL BE MUTED DURING ANY TRANSMIT. COM 3 AUDIO WILL ONLY BE MUTED WHEN THE PILOT TRANSMITS.
16. 2 STAGE MOMENTARY SWITCH. FIRST DETENT: KEYED INTERCOM. SECOND DETENT: MICROPHONE AUDIO AND PTT ACTIVE. PROVIDES KEYED INTERCOM IN HIGH NOISE ENVIRONMENTS.
17. CONNECT TO GROUND FOR TIMES TEN (20 DB) GAIN, OR INSTALL SWITCH TO SELECT BETWEEN UNITY GAIN (0 DB) AND TIMES TEN GAIN (20 DB) FOR MUSIC. THIS FUNCTION APPLIES ONLY TO UNITS WITH MOD 5 INCORPORATED.

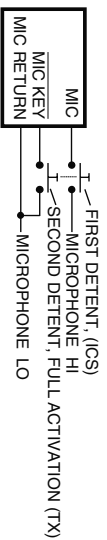

Figure B7. J2 INTERCONNECT WIRING DIAGRAM

APPENDIX C

STC PERMISSION

C.1 GENERAL

Consistent with N8110.69 or Order 8110.4, Aviation Authority approved installers are hereby granted permission to use STC #SA00710WI data to modify aircraft.

United States of America
Department of Transportation -- Federal Aviation Administration

Supplemental Type Certificate

[RL1] *Number* SA00710WI

This certificate issued to Garmin International
1200 E 51st St.
Olathe, KS 66062

certifies that the change in the type design for the following product with the limitations and conditions therefor as specified herein meets the airworthiness requirements of Part 3 of the Civil Air Regulations.

Original Product - Type Certificate Number : A350
Make : Piper
Model : PA-32

Description of Type Design Change:

Installation of GARMIN GMA 340 Audio Panel in accordance with GARMIN Corporation Master Drawing List, Drawing No. 005-00083-00, Revision A, dated May 13, 1998, or later FAA approved revision.

Limitations and Conditions: Compatibility of this design change with previously approved modifications must be determined by the installer

If the holder agrees to permit another person to use this certificate to alter the product, the holder shall give the other person written evidence of that permission.

This certificate and the supporting data which is the basis for approval shall remain in effect until surrendered, suspended, revoked or a termination date is otherwise established by the Administrator of the Federal Aviation Administration.

Date of application : February 23, 1998

Date reissued :

Date of issuance : October 02, 1998

Date amended :



By direction of the Administrator

William C. Schinstock
(Signature)

For C. Dale Bleakney
GARMIN Program Manager
Wichita Aircraft Certification Office

(Title)

Any alteration of this certificate is punishable by a fine of not exceeding \$1,000, or imprisonment not exceeding 3 years, or both.

FAA Form B110-2(10-68) PAGE 1 of 2 PAGES

This certificate may be transferred in accordance with FAR 21.47.