

CONTINENTAL AIRCRAFT ENGINE

MAINTENANCE MANUAL

**STANDARD PRACTICE
FOR SPARK IGNITED ENGINES**



Technical Portions Accepted by the Federal Aviation Administration

Publication M-0

©2017 CONTINENTAL MOTORS

CHANGE 3

JAN 2017



Supersedure Notice

This manual incorporates maintenance and service information contained in Continental Motors Service Documents common to the horizontally opposed, spark ignition, AvGas aircraft engines conforming to Type Certificate held by Continental Motors. This document is supplemental to the Instructions for Continued Airworthiness provided in the manuals listed in Section 1-1.1. Instructions contained in the Service Documents listed in Section 1-2.4 are superseded by instructions in this manual upon release, except for those Mandatory Service Bulletins (MSBs) and Critical Service Bulletins (CSBs).

Effective Changes for this Manual

0	15 April 2016		
1	30 May 2016		
2	30 Sep 2016		
3	15 Jan 2017		

List of Effective Pages

Document Title: Standard Practice Maintenance Manual
 Publication Number: M-0

Initial Publication Date: 15 April 2016

Page	Change	Page	Change	Page	Change	Page	Change
Cover.....	3	2-14 thru 2-24.....	0	6-8 thru 6-10	3	6-97	0
A.....	3	3-1 thru 3-2.....	0	6-11 thru 6-15	0	6-98 thru 6-100.....	3
B.....	3	3-3	3	6-16 thru 6-17	2	6-101	1
C (blank).....	1	3-4	0	6-18.....	3	6-102.....	0
i thru ii.....	0	3-5	3	6-19 thru 6-22	0	6-103.....	1
iii thru xviii.....	1	3-6	0	6-23.....	2	6-104 thru 6-115.....	0
1-1 thru 1-10.....	0	3-7 thru 3-8.....	3	6-24 thru 6-29	0	6-116	1
1-11	2	3-9	1	6-30.....	2	6-117 thru 6-132.....	0
1-12	3	3-10 thru 3-24	0	6-31.....	0	6-133 thru 6-135.....	1
1-13 thru 1-16.....	0	4-1 thru 4-2	0	6-32.....	3	6-136	0
2-1	0	5-1 thru 5-8.....	0	6-33 thru 6-51	0	6-137 thru 6-138.....	1
2-2 thru 2-4.....	1	6-1 thru 6-2.....	0	6-52.....	3	6-139.....	0
2-5 thru 2-6.....	0	6-3	2	6-53 thru 6-66	0	6-140	1
2-7 thru 2-8.....	1	6-4 thru 6-5.....	3	6-67.....	1	6-141	0
2-9 thru 2-12.....	0	6-6	1	6-68 thru 6-95	0	6-142.....	3
2-13	3	6-7	0	6-96.....	1	6-143 thru 6-145.....	0

Published and printed in the U.S.A. by Continental Motors

Available exclusively from the publisher: P.O. Box 90, Mobile, AL 36601

Copyright © 2016, 2017 Continental Motors. All rights reserved. This material may not be reprinted, republished, broadcast, or otherwise altered without the publisher's written permission. This manual is provided without express, statutory, or implied warranties. The publisher will not be held liable for any damages caused by or alleged to be caused by use, misuse, abuse, or misinterpretation of the contents. Content is subject to change without notice. Other products and companies mentioned herein may be trademarks of the respective owners.



List of Effective Pages, cont.

Page	Change	Page	Change	Page	Change	Page	Change
6-146	3	8-17 thru 8-26	0	12-2 thru 12-12	0		
6-146.1 added	3	9-1.....	1	A-1 thru A-6.....	0		
6-146.2 added	3	9-2 thru 9-6	0	B-1	1		
6-146.3 added	3	10-1 thru 10-2	0	B-2 thru B-7	0		
6-146.4 added	3	10-3.....	1	B-8	1		
6-146.5 added	3	10-4 thru 10-8	0	B-9 thru B-16.....	0		
6-146.6 added	3	10-9 thru 10-10	2	C-1 thru C-4	0		
6-147	3	10-11.....	1	C-5 thru C-7	3		
6-148	2	10-12.....	2	C-8 thru C-9	1		
6-149 thru 6-151	0	10-13.....	2	C-10 thru C-18	0		
6-152	2	10-14.....	3	C-19	1		
6-153 thru 6-154	1	10-15.....	1	C-20 thru C-26	0		
6-155	0	10-16 thru 10-18	2				
6-156	1	10-19 thru 10-21	0				
6-157	0	10-22.....	1				
6-158	3	10-23 thru 10-24	0				
6-159	1	10-25.....	1				
6-160 thru 6-164	0	10-26 thru 10-37	0				
6-165	3	10-38.....	3				
6-166 thru 6-171	0	10-39 thru 10-40	1				
6-172	1	10-41 thru 10-62	0				
6-173 thru 6-174	0	10-63.....	3				
7-1 thru 7-2	0	10-64 thru 10-69	0				
7-3	3	10-70.....	3				
7-4 thru 7-7	0	10-71 thru 10-93	0				
7-8	1	10-94 thru 10-95	3				
7-9	0	10-96 thru 10-99	0				
7-10	1	10-100 thru 10-101	3				
7-11 thru 7-17	0	10-102 thru 10-103	0				
7-18	3	10-104.....	1				
7-19 thru 7-23	0	10-105.....	0				
7-24	1	10-106.....	1				
7-25 thru 7-30	0	10-107 thru 10-108	0				
8-1 thru 8-15	0	11-1 thru 11-8.....	0				
8-16	2	12-1.....	1				



Intentionally Left Blank



PREFACE

This manual was developed in accordance with Title 14, Code of Federal Regulations (CFR) Part 33, §33.4 as the Instructions for Continued Airworthiness (ICA) for Standard Practices. Except for authorized owner preventive maintenance, defined in Title 14, Code of Federal Regulations (CFR) Part 43 §§43.3 and 43.13, Continental Motors ICAs are written for exclusive use by FAA (or equivalent authority) licensed mechanics or FAA (or equivalent authority) certified repair station employees. Information and instructions contained in this manual anticipate the user possesses and applies the knowledge, training, and experience commensurate with the requirements to meet the prerequisite FAA license and/or certification requirements. No other use is authorized. It is the responsibility of the owner to verify the person or facility operating, maintaining or servicing the engine uses the most current ICA, including manual change pages, service documents and FAA Airworthiness Directives (ADs), to perform those functions.

Continental Motors provides Instructions for Continued Airworthiness (ICA) based on the design, testing, and certification of engines and parts for which Continental Motors is the holder of the Type Certificate (TC) or Parts Manufacture Approval (PMA) issued by the Federal Aviation Administration (FAA). Instructions in Continental Motors manuals, which include maintenance, repair limits, and overhaul instructions, are applicable only to engines and parts supplied by Continental Motors.

Installation of aftermarket parts on a Continental Motors engine constitutes a deviation from type-design criteria. Continental Motors has not participated in design, test, or certification of any aftermarket parts. Continental Motors does not provide product manufacturing specifications to aftermarket parts manufacturers and accepts no liability for the suitability, durability, longevity, or safety of such parts installed on Continental Motors engines. Installation of aftermarket parts on a Continental Motors engine must be performed using Instructions for Continued Airworthiness prepared by the manufacturer and found acceptable by the FAA for the subject installation. Continental Motors ICAs must not be used for such parts.

WARNING

Ensure you have the latest revision of this manual, any applicable change pages, FAA Airworthiness Directives and Continental Motors service documents prior to commencing engine service, inspection, maintenance, or overhaul.

To facilitate the use of current data, the latest revision of the Instructions for Continued Airworthiness and applicable change pages are available to all registered engine owners at no cost on the Continental Motors web site. The information available includes a listing of the latest manual versions, illustrated parts catalogs, access to FAA Airworthiness Directives, Service Documents, and other information applicable to the ICAs.

Electronic versions of all current Continental Motors publications are available on the Continental Motors web site to Fixed Base Operators (FBOs), mechanics and others who subscribe to Continental Motors Internet Services. Printed copies of manuals and service subscriptions are also available. Refer to "Publication Access" in Section 1-2.1.



Intentionally Left Blank



Chapter 1. Introduction

1-1.Scope and Purpose of This Manual.....	1-1
1-1.1.Instructions for Continued Airworthiness.....	1-1
1-1.2.Advisories.....	1-3
1-1.3.Effectivity Symbols.....	1-3
1-1.4.Using this Manual.....	1-4
1-1.5.Compliance.....	1-6
1-1.6.Order of Precedence.....	1-7
1-2.Publications.....	1-7
1-2.1.Publication Access.....	1-7
1-2.2.Publication Changes.....	1-7
1-2.3.Update/Change Distribution.....	1-8
1-2.4.Service Documents.....	1-10
1-2.4.1.Service Documents Incorporated in this Manual.....	1-11
1-2.4.2.Service Documents Released After Publication.....	1-13
1-2.5.Related Publications.....	1-15
1-2.5.1.Suggestions and Corrections.....	1-15
1-3.Contact Information.....	1-16
1-4.Service Parts.....	1-16
1-4.1.Service Part Applicability and Availability.....	1-16
1-4.2.Part Supersedure.....	1-16

Chapter 2. Tools

2-1.Special Tools.....	2-1
2-1.1.Vendor Contact Information.....	2-7
2-2.Mechanic's Tools.....	2-23

Chapter 3. Lubricants, Sealants, and Adhesives

3-1.Engine Oil Specifications.....	3-1
3-2.Oil Change Intervals.....	3-3
3-3.Additives.....	3-3
3-3.1.General Sealant Application Instructions.....	3-10
3-3.1.1.Four Cylinder Engine Crankcase Threading.....	3-11
3-3.1.2.Six Cylinder Engine Crankcase Threading.....	3-13
3-3.2.Scavenge Pump Body Sealant and Threading.....	3-17
3-3.3.Oil Pump Assembly Sealant and Threading.....	3-18
3-3.4.Starter Adapter Assembly Sealant and Threading.....	3-22
3-3.5.Starter Adapter Accessory Drive Cover Sealant and Threading.....	3-23



Chapter 4. Airworthiness Limitation Section

Chapter 5.Engine Removal & Installation

5-1.Engine Removal.....	5-1
5-1.1.Tools and Consumable Supplies	5-1
5-1.2.Engine Removal Procedure.....	5-1
5-2.Engine Installation	5-2
5-2.1.Common Tools and Consumable Supplies	5-2
5-2.2.Engine Receipt and Handling	5-2
5-2.3.Uncrating the Engine	5-3
5-2.4.Crating an Engine for Shipping	5-3
5-2.5.Acceptance Inspection	5-3
5-2.6.Engine Transport.....	5-4
5-2.7.Engine Installation Procedures.....	5-4
5-2.8.Engine Adjustments and Component Replacement by OEMs and STC Converters.....	5-5
5-2.9.Engine Pre-oiling	5-7

Chapter 6. Engine Inspection and Service

6-1.Engine Inspection Introduction.....	6-1
6-2.Inspection and Maintenance Schedule.....	6-1
6-3.Time Between Overhaul	6-1
6-4.Scheduled Inspections.....	6-5
6-4.1.One Time Post - Installation Inspections	6-6
6-4.2.25-Hour Initial Operation Inspection.....	6-7
6-4.3.50-Hour Engine Inspection	6-8
6-4.4.100-Hour (Annual) Engine Inspection.....	6-9
6-4.5.500-Hour Engine Inspection	6-11
6-4.6.Visual Inspection.....	6-12
6-4.7.Engine Operational Check	6-14
6-4.7.1.Fuel Injection System Specifications.....	6-15
6-4.7.2.Maintenance Preflight Inspection	6-21
6-4.7.3.Oil Pump Operational Check	6-23
6-4.7.4.Fuel System Operational Check	6-23
6-4.7.5.Magneto RPM Drop Check	6-31
6-4.7.6.Engine Shutdown.....	6-32
6-4.8.Engine Oil Servicing.....	6-33
6-4.8.1.Check and Replenish Engine Oil Level.....	6-33
6-4.8.2.Oil Change	6-49
6-4.8.3.Check for Oil Leaks.....	6-51
6-4.8.4.Oil Sample Collection.....	6-51
6-4.8.5. Oil Trend Monitoring and Spectrographic Oil Analysis	6-52
6-4.9.Ignition System Maintenance.....	6-53
6-4.9.1.Ignition Timing	6-53
6-4.9.2.Spark Plug Maintenance	6-61
6-4.9.3.Ignition Harness Maintenance	6-65
6-4.10.Engine Adjustments	6-67
6-4.10.1.Oil Pressure Adjustment	6-67



6-4.10.2.Fuel System Adjustment	6-69
6-4.10.3.Manifold Pressure Adjustment.....	6-90
6-4.10.4.Belt Tension Check and Adjustment	6-96
6-4.11.Cylinder Inspections.....	6-102
6-4.11.1.Cylinder Visual Inspection.....	6-103
6-4.11.2.Differential Pressure Test.....	6-104
6-4.11.3.Cylinder Borescope Inspection	6-112
6-4.11.4.Cylinder to Crankcase Mounting Deck Inspection	6-116
6-4.11.5.Baffle Inspection	6-117
6-4.11.6.Cowling Inspection	6-122
6-4.12.Crankcase Inspection.....	6-122
6-4.12.1.Crankcase Critical Stress Areas	6-124
6-4.13.Engine Mount Inspection	6-130
6-4.14.Induction System Inspection	6-130
6-4.15.Ignition System Inspection.....	6-132
6-4.15.1.Impulse Coupling Functional Check.....	6-134
6-4.15.2.Starting Vibrator Functional Check	6-135
6-4.15.3.Magneto Drive Coupling Inspection.....	6-135
6-4.16.Engine Gauge Inspection	6-136
6-4.17.Fuel System Inspection	6-137
6-4.18.Throttle and Mixture Control Lever Inspection	6-138
6-4.19.Engine Control Linkage Inspection.....	6-140
6-4.20.Induction System Drain Inspection	6-142
6-4.20.1.Induction System Drain Inspection (Naturally aspirated engines)	6-142
6-4.20.2.Induction System Drain Inspection (Turbocharged engines)	6-143
6-4.21.Turbocharger and Exhaust System Inspection	6-144
6-4.22.Alternator Inspection.....	6-148
6-4.22.1.Alternator Drive Hub Inspection	6-148
6-4.22.2.Alternator Drive Hub Inspection	6-150
6-5.Unscheduled Maintenance	6-152
6-5.1.Propeller Strike.....	6-152
6-5.1.1.Propeller Strike Inspection.....	6-152
6-5.2.Hydraulic Lock Inspection.....	6-153
6-5.3.Engine Overspeed Inspections	6-155
6-5.3.1.Category I Overspeed Inspection.....	6-156
6-5.3.2.Category II Overspeed Inspection.....	6-156
6-5.3.3.Category III Overspeed Inspection	6-157
6-5.4.Turbocharger Overboost.....	6-157
6-5.5.Lightning Strike Inspection.....	6-158
6-5.6.Contaminated Fuel System Inspection.....	6-158
6-5.7.Foreign Object Contamination Inspection	6-159
6-6. Inspection Checklists	6-160

Chapter 7. Engine Operation

7-1.Introduction.....	7-1
7-2.Flight Prerequisites.....	7-1
7-2.1.Oil Change Interval.....	7-1
7-2.2.Engine Fuel Requirements	7-2
7-2.3.Engine Operation after Cylinder Replacement and/or Major Overhaul	7-6



Table of Contents

7-2.4.Flight Check and Break-In.....	7-8
7-2.4.1.Engine Break-In.....	7-8
7-2.4.2.Flight Check.....	7-9
7-3.Normal Operation.....	7-18
7-3.1.Pre-operational Requirements.....	7-18
7-3.2.Engine Start.....	7-19
7-3.2.1.Cold Start.....	7-20
7-3.2.2.Flooded Engine.....	7-20
7-3.2.3.Hot Start.....	7-21
7-3.3.Ground Run-up.....	7-22
7-3.4.Engine Shutdown.....	7-24
7-4.Engine Operation in Abnormal Environments.....	7-25
7-4.1.Engine Operation in Extreme Cold.....	7-25
7-4.1.1.Engine Preheating.....	7-26

Chapter 8. Troubleshooting

8-1.General Troubleshooting.....	8-2
8-1.1.General Troubleshooting for Engines equipped with a Carburetor.....	8-2
8-1.2.General Troubleshooting for Engines with CM Continuous Flow Fuel Injection Systems....	8-3
8-1.3.Engine Runs Rough.....	8-4
8-1.3.1.Engine Runs Rough (equipped with Carburetor).....	8-4
8-1.3.2.Engine Runs Rough (equipped with CM Continuous Flow Fuel Injection System).....	8-5
8-1.4.Engine Will Not Run.....	8-6
8-1.5.Engine Indication Malfunctions.....	8-7
8-1.6.Engine Performance Malfunctions.....	8-8
8-2.Induction System.....	8-9
8-2.1.Engine Will Not Start.....	8-9
8-2.2.Engine Will Not Run.....	8-10
8-2.3.Engine Lacks Power/Manifold Pressure Low (Naturally Aspirated Models).....	8-10
8-2.4.Engine Lacks Power/Manifold Pressure Low (Turbocharged Models).....	8-11
8-3.CM Continuous Flow Fuel Injection System.....	8-12
8-3.1.Engine Will Not Start.....	8-12
8-3.2.Fluctuating or Erroneous Fuel Flow.....	8-13
8-3.3.Poor Acceleration.....	8-13
8-3.4.Fuel Injector Operational Check.....	8-14
8-4.Charging System.....	8-16
8-5.Starting System.....	8-16
8-6.Ignition System.....	8-17
8-6.1.Ignition Harness and Spark Plug Diagnostics.....	8-18
8-7.Lubrication System.....	8-19
8-8.Engine Cylinders.....	8-21
8-9.Crankcase.....	8-23
8-9.1.Excess Crankcase Pressure.....	8-24
8-10.Turbocharger and Exhaust System.....	8-25



Chapter 9. Engine Preservation and Storage

9-1.Preserving and Storing an Engine	9-1
9-1.1.Engine Preservation Checklist	9-1
9-1.2.New or Unused Engine Storage	9-1
9-1.3.Temporary Storage	9-1
9-1.4.Indefinite Storage	9-3
9-1.5.Return an Engine to Service after Storage	9-4

Chapter 10.Non-Overhaul Repair and Replacement

10-1.Parts Replacement.....	10-1
10-2.Fuel Injector Replacement	10-3
10-2.1.Nozzle Identification	10-3
10-2.2.Fuel Injector Removal (Turbocharged engines).....	10-4
10-2.3.Fuel Injector Installation (Turbocharged engines)	10-4
10-2.4.Fuel Injector Removal (Naturally Aspirated engines)	10-6
10-2.5.Fuel Injector Installation (Naturally Aspirated engines).....	10-6
10-3.Induction Drain Connector Replacement.....	10-8
10-3.1.Induction Drain Connector Removal and Cleaning	10-8
10-3.2.Induction Drain Connector Installation.....	10-8
10-4.Alternator Replacement	10-9
10-4.1. Gear Driven Alternator Replacement, Forward Mount	10-9
10-4.1.1.Gear Driven Alternator Removal	10-9
10-4.1.2. Alternator Drive Hub Removal	10-11
10-4.1.3.Alternator Drive Hub Installation	10-11
10-4.1.4.Alternator Drive Hub Slippage Inspection	10-12
10-4.1.5.Gear Driven Alternator Installation	10-13
10-4.2.Gear Driven Alternator Replacement, Aft Mount	10-14
10-4.2.1.Gear Driven Alternator Removal	10-14
10-4.2.2.Alternator Drive Hub Removal	10-16
10-4.2.3.Alternator Drive Hub Installation	10-16
10-4.2.4.Gear Driven Alternator Installation	10-18
10-4.3.Alternator Service Instructions.....	10-19
10-5.Magneto Replacement.....	10-21
10-5.1.Continental Motors Magneto Removal	10-21
10-5.2.Continental Motors Magneto Installation	10-22
10-5.3.Champion (Slick) Magneto Removal.....	10-24
10-5.4.Champion (Slick) Magneto Installation	10-25
10-5.5.Magneto Filter Replacement	10-27
10-5.5.1.Continental Motors Magneto Filter Replacement.....	10-27
10-5.5.2.Champion (Slick) Magneto Filter Replacement	10-29
10-6.Cylinder Repairs.....	10-31
10-6.1.Cylinder Replacement.....	10-32
10-6.1.1.Cylinder Removal	10-32
10-6.1.2.Cylinder Installation.....	10-34
10-6.1.3.Cylinder Torque	10-36
10-6.2.Cylinder Position Numbers	10-37



Table of Contents

10-6.3.Cylinder Head Repair.....	10-37
10-6.4.Cylinder Fin Tip Repair	10-38
10-6.5.Cylinder Barrel Repair	10-38
10-6.6.Cylinder Stud Replacement	10-38
10-6.7.Spark Plug Heli-coil Replacement.....	10-39
10-6.8.Cylinder Protective Coatings	10-40
10-6.9.Cylinder Bore and Piston Fit Specifications.....	10-41
10-6.10.Legacy Product Replacement Valves.....	10-52
10-7.Crankcase Repair	10-55
10-8.Piston Replacement.....	10-56
10-9.Crankshaft Repair	10-57
10-9.1.Crankshaft Counterweight Inspection and Repair	10-57
10-9.1.1.Crankshaft Counterweight Removal.....	10-76
10-9.1.2.Counterweight Identification	10-77
10-9.1.3.Crankshaft Counterweight Inspection	10-82
10-9.1.4.Crankshaft Counterweight Bushing Bore Inspection	10-83
10-9.1.5.Crankshaft Counterweight Bushing Replacement.....	10-85
10-9.1.6.Crankshaft Hanger Blade Bushing Inspection.....	10-88
10-9.2.Oil Control Plug Replacement	10-91
10-9.3.Crankshaft Plating Overhaul.....	10-93
10-9.4.Connecting Rod Replacement.....	10-94
10-9.4.1.Connecting Rod Dimensional Inspection	10-94
10-9.4.2.Connecting Rod Piston Pin Bushing Replacement.....	10-99
10-9.4.3.Connecting Rod Piston Pin Boring.....	10-101
10-10.Crankshaft Nose Oil Seal Replacement.....	10-102
10-10.1.Solid Nose Oil Seal Removal.....	10-102
10-10.2.Solid Nose Oil Seal Installation.....	10-103
10-10.3.Split Nose Oil Seal Removal	10-105
10-10.4. Split Type Nose Oil Seal Installation.....	10-105
10-11.Exhaust Flange to Cylinder Installation.....	10-107

Chapter 11. Non-Destructive Inspection

11-1.Visual Inspection.....	11-1
11-1.1.Gear Tooth Inspection	11-2
11-2.Fluorescent Penetrant Inspection	11-3
11-3.Magnetic Particle Inspection.....	11-4
11-3.1.Connecting Rod Magnetic Particle Inspection.....	11-6
11-4.Ultrasonic Inspection	11-7
11-4.1.Ultrasonic Inspection Certification	11-7
11-4.2.Crankshaft Ultrasonic Inspection.....	11-8

Chapter 12. Engine Cleaning

12-1.Engine and Component Cleaning	12-1
12-1.1.Cylinder Cleaning	12-6
12-1.2.Piston Cleaning	12-7



12-1.3.Cleaning Exhaust Parts.....	12-8
12-1.4.Cleaning Aluminum Alloy Parts.....	12-8
12-2.Dry Blasting	12-9
12-3.Vapor Blasting.....	12-9
12-4.Protective Coatings	12-10
12-4.1.Alodine.....	12-10
12-4.2.Aviation Oil.....	12-10
12-4.3.Paint.....	12-11

Appendix A.Glossary

A-1.Acronyms	A-1
A-2.Terms and Definitions	A-3

Appendix B.Torque Specifications

B-1.General Information	B-1
B-1.1.Torque Tips.....	B-2
B-2.Part Supersedure.....	B-3
B-3.Torque Wrench and Extension Calculations.....	B-4

Appendix C.Maintenance Standards

C-1.Handling Parts	C-1
C-2.Replacement Parts	C-3
C-2.1.Background.....	C-3
C-2.2.Acceptable Replacement Parts	C-3
C-2.2.1.Know Your Supplier	C-3
C-2.3.100% Parts Replacement Requirements.....	C-4
C-2.4.Mandatory Overhaul Replacement Parts.....	C-5
C-2.5.Authorized Oversize/Undersize Parts.....	C-7
C-2.6.Engine Data Plate Replacement	C-8
C-2.6.1. Removal and Installation of Engine Data Plate.....	C-8
C-2.7.Special Instructions.....	C-9
C-3.Safety Wiring Hardware.....	C-10
C-4.Tab Washer Installation	C-12
C-5.Heli-Coil® Insert Replacement.....	C-13
C-5.1.Heli-Coil Removal.....	C-14
C-5.2.Heli-Coil Insertion.....	C-15
C-6.Stud Replacement.....	C-16
C-6.1.Stud Removal	C-16
C-6.1.1.Size-on-Size Rosan® Stud Removal.....	C-16
C-6.1.2.Step-Type Rosan® Stud Removal.....	C-17
C-6.2.Stud Installation.....	C-19
C-6.2.1.Rosan® Stud Installation.....	C-20



Table of Contents

C-7.Cotter Pin Installation.....	C-21
C-8.Fuel System Service.....	C-22
C-8.1.Fuel System Purge.....	C-22
C-9.Gasket Maker® Application	C-23
C-10.Gasket Installation.....	C-24
C-11.Hose and Tubing Installation.....	C-25
C-12.Harness Routing.....	C-26



LIST OF TABLES

Table 1-1.	Service Documents Incorporated in Manual	1-11
Table 1-2.	Related Publications	1-15
Table 2-1.	Special Tools List	2-1
Table 2-2.	Tools, Accessories, and Supply Vendors	2-7
Table 2-3.	Common Tools	2-23
Table 3-1.	Qualified SAE J1899 Ashless Dispersant Engine Oil	3-2
Table 3-2.	Break-in Oil	3-2
Table 3-3.	Preservative Oil	3-2
Table 3-4.	Sealants	3-4
Table 3-5.	Lubricants	3-5
Table 3-6.	Adhesives	3-7
Table 3-7.	Miscellaneous	3-9
Table 5-1.	Authorized Adjustments and Replacements	5-6
Table 6-1.	Engine Time Between Overhaul (TBO)	6-3
Table 6-2.	Engine Inspection and Maintenance Schedule	6-5
Table 6-3.	Engine Operation Prerequisites	6-14
Table 6-4.	Fuel System Adjustment Values	6-15
Table 6-5.	Static Ground Setup Compensation Table	6-19
Table 6-6.	IO-240-A, B With Standard Fuel Pump	6-20
Table 6-7.	Magneto Timing Specifications - Geared Engines	6-53
Table 6-8.	Magneto Timing Specifications - Direct Drive Engines	6-53
Table 6-9.	Spark Plug Application Chart	6-62
Table 6-10.	Spark Plug Rotation Chart	6-64
Table 6-11.	IO-360-D/DB Engine Altitude Leaning Schedule	6-83
Table 6-12.	IO-360-ES Engine Altitude Leaning Schedule	6-84
Table 6-13.	IO-360-ES (Cirrus SR20) Engine Altitude Leaning Schedule	6-85
Table 6-14.	IO-550-A Engine Altitude Leaning Schedule	6-86
Table 6-15.	IO-550-B Engine Altitude Leaning Schedule	6-87
Table 6-16.	IO-550-C Engine Altitude Leaning Schedule	6-88
Table 6-17.	IO-550-D, E, F, & L Engine Altitude Leaning Schedule	6-89
Table 6-18.	VAPC Parameters	6-94
Table 6-19.	Cylinder Inspection Tasks and References	6-102
Table 6-20.	Additional Cylinder Service Document References	6-102
Table 6-21.	Differential Pressure Test Results	6-110
Table 6-22.	Borescope Inspection Objectives and Corrective Actions	6-113
Table 6-23.	Crankcase Casting Numbers	6-122
Table 6-24.	Exhaust Inspection Criteria	6-144
Table 6-25.	Overspeed Categories	6-155
Table 6-26.	Engine Operational Checklist	6-161
Table 6-27.	25-Hour Initial Operation Inspection Checklist	6-163
Table 6-28.	50-Hour Engine Inspection Checklist	6-165
Table 6-29.	100-Hour Engine Inspection Checklist	6-167
Table 6-30.	500-Hour Engine Inspection Checklist	6-169
Table 6-31.	Cylinder Inspection Checklist	6-171



Table of Contents

Table 7-1.	Aviation Fuel Specifications	7-3
Table 7-2.	Authorized Fuels by Aircraft Model	7-3
Table 7-3.	IO-360-D/DB Engine Altitude Leaning Schedule	7-11
Table 7-4.	IO-360-ES Engine Altitude Leaning Schedule	7-12
Table 7-5.	IO-360-ES (Cirrus SR20) Engine Altitude Leaning Schedule	7-13
Table 7-6.	IO-550-A Engine Altitude Leaning Schedule	7-14
Table 7-7.	IO-550-B Engine Altitude Leaning Schedule	7-15
Table 7-8.	IO-550-C Engine Altitude Leaning Schedule	7-16
Table 7-9.	IO-550-D, E, F, & L Engine Altitude Leaning Schedule	7-17
Table 9-1.	Engine Preservation Checklist	9-5
Table 10-1.	Non-Overhaul Parts Replacement Reference	10-1
Table 10-2.	Parts Repair Reference	10-2
Table 10-3.	Parts Handling Guidelines	10-2
Table 10-4.	Alternator Drive Hub Slippage	10-12
Table 10-5.	Alternator Cross Reference	10-20
Table 10-6.	Cylinder Repair vs. Replacement Guidelines	10-31
Table 10-7.	5.250 Inch Cylinder Barrel Dimensions	10-42
Table 10-8.	5.250 Inch Cylinder Barrel Dimensions	10-43
Table 10-9.	Piston to Cylinder Clearance	10-43
Table 10-10.	Piston to Cylinder Clearance	10-43
Table 10-11.	Piston to Cylinder Clearance	10-43
Table 10-12.	Ring Gap Specifications	10-44
Table 10-13.	5.000 Inch Cylinder Barrel Dimensions	10-45
Table 10-14.	Piston to Cylinder Clearance	10-45
Table 10-15.	Piston to Cylinder Clearance	10-46
Table 10-16.	Ring Gap Specifications	10-46
Table 10-17.	4.438 Inch Cylinder Barrel Dimensions	10-47
Table 10-18.	Piston to Cylinder Clearance	10-47
Table 10-19.	Ring Gap Specifications	10-48
Table 10-20.	4.062 Inch Cylinder Barrel Dimensions	10-49
Table 10-21.	Piston to Cylinder Clearance	10-49
Table 10-22.	Ring Gap Specifications	10-50
Table 10-23.	Ring Gap Specifications	10-50
Table 10-24.	Engine to Piston Cross Reference	10-51
Table 10-25.	Engines Serial Number Applicability	10-52
Table 10-26.	Replacement Components for Low Compression Ratio Cylinders	10-53
Table 10-27.	Cylinder Part Number Conversion	10-53
Table 10-28.	Engine Power Train	10-58
Table 10-29.	Crankshaft Assembly Part Number History	10-65
Table 10-30.	Crankshaft Assemblies	10-70
Table 10-31.	Crankshaft Hanger Blade Bushing Sizes	10-73
Table 10-32.	Wide Rod Crankshaft	10-74
Table 10-33.	Counterweight Supersedure	10-76
Table 10-34.	Counterweight Bushing Bore Dimensions	10-84
Table 10-35.	Counterweight Bushing Bore Dimensions	10-87
Table 10-36.	Counterweight Hanger Blade Bushing Dimensions	10-89



Table 10-37.	Crankshaft Oil Plug Installation Specifications	10-91
Table 10-38.	Connecting Rod Specifications	10-97
Table 10-39.	Exhaust Gaskets, Nuts, and Nut Torque Values	10-108
Table 11-1.	Parts Requiring Fluorescent Penetrant Inspection	11-3
Table 11-2.	Magnetic Particle Inspection Reference	11-5
Table 11-3.	Connecting Rod Magnetic Particle Inspection Criteria	11-6
Table 11-4.	Crankshaft Ultrasonic Inspection Pass/Fail Action	11-8
Table 12-1.	Aircraft Engine Parts Cleaning Guidelines	12-2
Table 12-2.	Cleaning Tips	12-5
Table 12-3.	Painting External Parts	12-11
Table B-1.	Appendix B, Quick Table Reference	B-1
Table B-2.	Component Specific Torque Specifications	B-6
Table B-3.	Specific Torque Specifications (Non-Lubricated Hardware)	B-13
Table B-4.	FADEC Components (Non-Lubricated Hardware)	B-13
Table B-5.	General Torque Specifications	B-14
Table B-6.	Hydraulic Line Torque Specifications	B-14
Table B-7.	Straight Thread Fitting Torque Specifications	B-15
Table B-8.	Hose Fitting (“B” Nut) Torque Specifications	B-15
Table C-1.	Mandatory Overhaul Replacement Parts	C-5
Table C-2.	Rosan® Stud Primary & Secondary Bore Specifications	C-17



LIST OF ILLUSTRATIONS

Figure 1-1.	Figure and Index Reference	1-5
Figure 1-2.	Change Page Identification	1-8
Figure 1-3.	List of Effective Pages	1-9
Figure 2-1.	Model E2M Differential Pressure Tester (built in Master Orifice Tool)	2-9
Figure 2-2.	Borescope (Autoscope®)	2-9
Figure 2-3.	Pulley Alignment Tool	2-10
Figure 2-4.	Model 20 ATM-C Porta-Test	2-10
Figure 2-5.	Gear Driven Alternator Drive Hub Torque Tool	2-11
Figure 2-6.	Alternator Drive Hub Torque Tool	2-12
Figure 2-7.	Worm Shaft Tool and Starter Adapter Disassembly Tool	2-12
Figure 2-8.	Oil Control Plug Installation Tool - 360 Engines	2-13
Figure 2-9.	Oil Control Plug Installation Tool - 470 Engines	2-13
Figure 2-10.	Oil Control Plug Installation Tool - 520/550 Permold Engines	2-14
Figure 2-11.	Oil Control Plug Installation Tool - 470/520/550 Sandcast Engines	2-14
Figure 2-12.	Oil Control Plug Leak Test Fixture	2-15
Figure 2-13.	Needle Bearing Installation Tool - Part 1	2-16
Figure 2-14.	Needle Bearing Installation Tool - Part 2	2-17
Figure 2-15.	Bearing Installation Tool	2-18
Figure 2-16.	Permold Crankcase Needle Bearing Installation Tool	2-18
Figure 2-17.	Sandcast Crankcase Needle Bearing Installation Tool	2-19
Figure 2-18.	Valve Guide Seal Installation Tool	2-19
Figure 2-19.	O-Ring Installation Tool	2-20
Figure 2-20.	Oil Seal Tool	2-20
Figure 2-21.	Helical Coil Extraction Tool	2-21
Figure 2-22.	Helical Coil Insertion Tool	2-21
Figure 2-23.	Helical Coil Expanding Tool	2-22
Figure 2-24.	Rosan® Stud Removal Tool	2-22
Figure 3-1.	Anti-Seize Lubricant Application	3-10
Figure 3-2.	Fuel Injection Sealant Application	3-10
Figure 3-3.	Crankcase Threading Diagram - C75, C85, C90, O200	3-12
Figure 3-4.	Crankcase Threading Diagram - O240, IO240, IOF240	3-12
Figure 3-5.	Crankcase Threading Diagram - O300	3-14
Figure 3-6.	Crankcase Threading Diagram - IO360, L/TSIO360	3-14
Figure 3-7.	Crankcase Threading Diagram - 520/550 Permold	3-15
Figure 3-8.	Crankcase Threading Diagram - 470/520/550 Sandcast	3-15
Figure 3-9.	Crankcase Threading Diagram - GTSIO520	3-16
Figure 3-10.	Scavenge Pump Body Threading Diagram	3-17
Figure 3-11.	Oil Pump Assembly Threading Diagram	3-18
Figure 3-12.	Oil Pump Assembly Threading Diagram	3-19
Figure 3-13.	Oil Pump Assembly Threading Diagram	3-20
Figure 3-14.	Oil Pump Assembly Threading Diagram	3-21
Figure 3-15.	Oil Pump Assembly Threading Diagram	3-21
Figure 3-16.	Starter Adapter Assembly Threading Diagram	3-22



Figure 3-17.	Accessory Drive Cover Threading Diagram	3-23
Figure 6-1.	Part No. MS51523-B4 Swivel Tee	6-25
Figure 6-2.	Model 20 ATM-C Porta-Test	6-26
Figure 6-3.	Typical Naturally Aspirated Fuel System Schematic	6-27
Figure 6-4.	Typical Naturally Aspirated Fuel System Schematic	6-27
Figure 6-5.	Typical Turbocharged Fuel System Schematic	6-28
Figure 6-6.	Typical Turbocharged Fuel System Schematic	6-28
Figure 6-7.	C-75, C-85, C-90 & O-200-A Oil Servicing Points (typical)	6-34
Figure 6-8.	O-200-D & X Oil Servicing Points	6-34
Figure 6-9.	IO-240-B Oil Servicing Points (typical)	6-35
Figure 6-10.	IO-360 Oil Servicing Points (typical)	6-36
Figure 6-11.	IO-360-AF/ES Oil Servicing Points	6-37
Figure 6-12.	TSIO-360 Oil Servicing Points (typical)	6-38
Figure 6-13.	O-470 Oil Servicing Points (typical)	6-39
Figure 6-14.	IO-470/TSIO-470 Oil Servicing Points (typical)	6-40
Figure 6-15.	GTSIO-520 Oil Servicing Points (typical)	6-41
Figure 6-16.	IO-550-A, B & C Oil Servicing Points	6-42
Figure 6-17.	IO-550-D, E & F Oil Servicing Points	6-43
Figure 6-18.	IO-550-G & N Oil Servicing Points	6-44
Figure 6-19.	IO-550-L Oil Servicing Points	6-45
Figure 6-20.	IO-550-P Oil Servicing Points	6-46
Figure 6-21.	IO-550-R Oil Servicing Points	6-47
Figure 6-22.	TSIO-550 Oil Servicing Points (typical)	6-48
Figure 6-23.	Disposable Oil Filter and Integral Screen	6-50
Figure 6-24.	O-200 28° BTC Timing	6-55
Figure 6-25.	O-200 24° BTC Timing	6-55
Figure 6-26.	Timing Disk and TDC Locator Installed	6-56
Figure 6-27.	No. 1 Cylinder Positioned at Top of Intake Stroke	6-57
Figure 6-28.	Crankshaft Positioned at TDC	6-57
Figure 6-29.	Cylinder No. 1 Top of Compression Stroke	6-58
Figure 6-30.	No. 1 Cylinder Full Advance Firing Position	6-59
Figure 6-31.	Spark Plug Inspection Criteria	6-61
Figure 6-32.	Lubricate Ignition Wire with MS-122AD	6-65
Figure 6-33.	Elbow Kit Assembly	6-66
Figure 6-34.	Oil Pressure Relief Valve Adjustment Screw Locations	6-68
Figure 6-35.	Fuel Pump, Naturally Aspirated Engine without integral Mixture Control	6-71
Figure 6-36.	Fuel Pump, Naturally Aspirated Engine with integral Mixture Control	6-71
Figure 6-37.	Throttle and Metering Assembly	6-72
Figure 6-38.	Throttle and Control Assembly, Front View	6-72
Figure 6-39.	Throttle and Control Assembly, Side View	6-73
Figure 6-40.	Altitude Compensating Fuel Pump (Auto-Lean), Naturally Aspirated Engine (without adjustable orifice)	6-76
Figure 6-41.	Altitude Compensating Fuel Pump (Auto-Lean), Naturally Aspirated Engine (with adjustable orifice)	6-76



Table of Contents

Figure 6-42.	Aneroid Equipped Fuel Pump, Turbocharged Engine	6-77
Figure 6-43.	Aneroid and Mixture Control Equipped Fuel Pump, Turbocharged Engine	6-77
Figure 6-44.	Fuel Pressure Regulator, Turbocharged Engine	6-79
Figure 6-45.	Altitude Leaning Schedule Adjustment Example	6-81
Figure 6-46.	Altitude Leaning after Correction	6-82
Figure 6-47.	IO-360-D/DB Altitude Leaning Schedule	6-83
Figure 6-48.	IO-360-ES Altitude Leaning Schedule	6-84
Figure 6-49.	IO-360-ES in Cirrus SR20 Altitude Leaning Schedule	6-85
Figure 6-50.	IO-550-A Altitude Leaning Schedule	6-86
Figure 6-51.	IO-550-B Altitude Leaning Schedule	6-87
Figure 6-52.	IO-550-C Altitude Leaning Schedule	6-88
Figure 6-53.	IO-55-D, E, F & L Altitude Leaning Schedule	6-89
Figure 6-54.	Fixed Wastegate (Typical)	6-91
Figure 6-55.	Fixed Wastegate (TSIO-520-T) (Typical)	6-92
Figure 6-56.	Sloped Controller	6-93
Figure 6-57.	Variable Absolute Pressure Controller	6-94
Figure 6-58.	Air Conditioning Compressor Belt Tensioning	6-96
Figure 6-59.	Optional Compressor Belt Tensioning (Typical)	6-97
Figure 6-60.	Alternator Belt Tensioning	6-98
Figure 6-61.	85 Amp Alternator Belt Adjustment	6-99
Figure 6-62.	Front Mount Belt Driven Alternator	6-100
Figure 6-63.	Aft Mounted Alternator Belt Tension Adjustment	6-101
Figure 6-64.	Cylinder Power Stroke Areas	6-103
Figure 6-65.	Model E2M Differential Pressure Tester	6-106
Figure 6-66.	Differential Pressure Test Equipment Usage	6-108
Figure 6-67.	Normal Combustion Chamber	6-114
Figure 6-68.	Burned Exhaust Valve	6-114
Figure 6-69.	Phosphate-Coated Cylinder w/Revised Hone Pattern	6-114
Figure 6-70.	Phosphated Cylinder Bore	6-114
Figure 6-71.	Cylinder Barrel Scoring and Piston Rub	6-115
Figure 6-72.	Typical Wear in Upper Ring Travel	6-115
Figure 6-73.	Typical Cylinder Wear	6-115
Figure 6-74.	Improperly Positioned Baffle Seals	6-118
Figure 6-75.	Improperly Positioned Baffle Seals	6-118
Figure 6-76.	Improperly Positioned Aft and Side Peripheral Baffle Seals	6-119
Figure 6-77.	Improperly Positioned Aft and Side Peripheral Baffle Seals	6-119
Figure 6-78.	Aft and Side Baffles with Air Gaps	6-120
Figure 6-79.	Cooling Loss Due to Gaps in Baffle Seals	6-120
Figure 6-80.	Cooling Loss Due to Gaps in Baffle Seals	6-121
Figure 6-81.	Crack in Non-Critical Area of Crankcase, typical	6-124
Figure 6-82.	O-200 Engine Crankcase	6-125
Figure 6-83.	IO/IOF-240 Engine Crankcase	6-125
Figure 6-84.	O-300 Engine Crankcase	6-126
Figure 6-85.	IO/LTSIO/TSIO-360 Series Engine Crankcase	6-126
Figure 6-86.	520/550 Permold Engine Crankcase	6-127



Figure 6-87. 470/520/550 Sandcast Engine Crankcase	6-127
Figure 6-88. GTSIO-520 Engine Crankcase	6-128
Figure 6-89. Induction Tube Bead Location	6-131
Figure 6-90. Properly Installed Induction Tube, Hose and Clamps	6-131
Figure 6-91. Serviceable Throttle/Mixture Control Lever & Shaft Splines	6-138
Figure 6-92. Worn Throttle and Mixture Control Lever & Shaft Splines	6-139
Figure 6-93. Throttle and Control Assembly Lubrication Points	6-141
Figure 6-94. Throttle and Metering Assembly Lubrication Points	6-141
Figure 6-95. Induction Port Drain Connectors	6-142
Figure 6-96. Exhaust Slip joint Inspection	6-145
Figure 6-97. V-band Clamp Inspection	6-145
Figure 6-98. Alternator Drive Hub	6-149
Figure 6-99. Alternator and Coupling Assembly	6-151
Figure 7-1. IO-360-D/DB Altitude Leaning Schedule	7-11
Figure 7-2. IO-360-ES Altitude Leaning Schedule	7-12
Figure 7-3. IO-360-ES in Cirrus SR20 Altitude Leaning Schedule	7-13
Figure 7-4. IO-550-A Altitude Leaning Schedule	7-14
Figure 7-5. IO-550-B Altitude Leaning Schedule	7-15
Figure 7-6. IO-550-C Altitude Leaning Schedule	7-16
Figure 7-7. IO-55-D, E, F & L Altitude Leaning Schedule	7-17
Figure 10-1. Fuel Injector Nozzle Identification (typical)	10-3
Figure 10-2. Turbo Fuel Injector Nozzle Assembly (typical)	10-5
Figure 10-3. Naturally Aspirated Engine Fuel Injector Nozzles	10-7
Figure 10-4. Alternator and Drive Hub	10-10
Figure 10-5. Alternator Drive Hub Spanner Wrench	10-12
Figure 10-6. Alternator and Drive Hub	10-15
Figure 10-7. Alternator and Drive Hub	10-15
Figure 10-8. Multi-Part Alternator Drive Hub	10-17
Figure 10-9. One Piece Alternator Drive Hub	10-17
Figure 10-10. Continental Motors Ignition System	10-23
Figure 10-11. Champion (Slick) Ignition System	10-26
Figure 10-12. Continental Motors Pressurized Magneto Filter (Typical)	10-28
Figure 10-13. Champion (Slick) Pressurized Magneto Filter (Typical)	10-30
Figure 10-14. Cylinder Base O-Ring supporting Connecting Rods	10-33
Figure 10-15. Cylinder Torque Sequence	10-36
Figure 10-16. Cylinder Position Number Location	10-37
Figure 10-17. 5.250 Inch Cylinder Measurement Locations	10-42
Figure 10-18. Ring Gap Measurement Location	10-44
Figure 10-19. 5.000 Inch Cylinder Measurement Locations	10-45
Figure 10-20. Ring Gap Measurement Location	10-46
Figure 10-21. 4.438 Inch Cylinder Measurement Locations	10-47
Figure 10-22. Ring Gap Measurement Location	10-48
Figure 10-23. 4.062 Inch Cylinder Measurement Locations	10-49
Figure 10-24. Ring Gap Measurement Location	10-50
Figure 10-25. Intake Valve Angle	10-54
Figure 10-26. Part No. 530864 Counterweight Assembly	10-77



Table of Contents

Figure 10-27. Part No. 531017 Counterweight Assembly	10-77
Figure 10-28. Part No. 639196 Counterweight Assembly	10-78
Figure 10-29. Part No. 639197 Counterweight Assembly	10-78
Figure 10-30. Part No. 639195 Counterweight Assembly	10-79
Figure 10-31. Part No. 639199 Counterweight Assembly	10-79
Figure 10-32. Part No. 652833 Counterweight Assembly	10-80
Figure 10-33. Part No. 627821 Counterweight Assembly	10-80
Figure 10-34. Part No. 639205 and 639210 Counterweight Assemblies	10-81
Figure 10-35. Crankshaft Counterweight Bump Service Inspection	10-82
Figure 10-36. Counterweight Bushing Bore Inspection	10-84
Figure 10-37. Counterweight Inspection, Repair and Installation	10-86
Figure 10-38. GTSIO-520 Counterweight Inspection, Repair and Installation	10-87
Figure 10-39. Crankshaft Hanger Blade Bushing Replacement	10-89
Figure 10-40. Crankshaft Oil Control Plug Leak Test	10-92
Figure 10-41. Crankshaft Helix Pattern	10-93
Figure 10-42. Connecting Rod Dimensions	10-96
Figure 10-43. Retainer Plate and Screws on Front of Crankcase	10-102
Figure 10-44. Crankshaft Nose Oil Seal Parts	10-103
Figure 10-45. Split Nose Oil Seal Parts	10-106
Figure 11-1. Gear Inspection Criteria	11-2
Figure 11-2. Crankshaft Ultrasonic Inspection Method Location	11-8
Figure B-1. Torque Wrench	B-4
Figure B-2. Drive extensions	B-4
Figure B-3. Extension increases applied torque	B-5
Figure B-4. Extension decreases applied torque	B-5
Figure C-1. Right-hand-thread safety wire installation	C-10
Figure C-2. Safety wire Patterns for Right-Hand Threads	C-11
Figure C-3. Tab Washer Installation	C-12
Figure C-4. Heli-Coil Extraction Tool	C-14
Figure C-5. Installing a Helical Coil Insert	C-15
Figure C-6. Rosan® Stud Removal Tool	C-17
Figure C-7. Rosan® Stud Removal Tool Installed on Stud	C-18
Figure C-8. Stud Sizes	C-19
Figure C-9. Minimum Material Thickness for Helical Coil insertion	C-19
Figure C-10. Rosan® Stud Installation Dimensions	C-20
Figure C-11. Cotter Pin Installation	C-21
Figure C-12. Installing Hoses and Fittings	C-25



Chapter 1. Introduction

1-1. Scope and Purpose of This Manual

This manual provides maintenance instructions for spark ignition, Standard Practices operating on aviation gasoline (AvGas). These Instructions for Continued Airworthiness (ICA) are supplied to the owner with the engine. Instructions in this manual are standard practices, with differences identified by model, for A-65, A-75, C-75, C-85, C-90, C-125, C-145, E-165, E-185, E-225, O-200, GO-300, O-300, IO-240, IOF-240, IO-346, IO-360, LTSIO-360, TSIO-360, O-470, IO-470, TSIO-470, GTSIO-520, IO-520, LTSIO-520, TSIO-520, IO-550, IOF-550, TSIO-550, TSIOF-550, TSIOL-550 and TIARA (6-285 and 6-320) series aircraft engines. For information specific to the Continental Motors engine series, accessories, or the airplane, refer to the appropriate manual. For the specific instructions regarding the electronic equipment on FADEC engines, or for unlisted engine models, refer to the primary ICA.

A list of tools for all applicable engines is provided in Chapter 2. Consumables items, such as lubricants, sealants, and adhesives are listed in Chapter 3. Airworthiness limitations are in Chapter 4. Chapter 5 contains generic installation instructions applicable to our engines. Chapter 6 provides schedule inspection and service intervals and instructions, as well as unscheduled maintenance instructions. Chapter 7 contains general engine operating instructions, applicable to all models. Chapter 8 contains engine troubleshooting instructions. Engine preservation and storage instructions are in Chapter 9. Non-overhaul engine part replacement instructions are in Chapter 10. Chapter 11 contains Non-Destructive Inspection guidelines. Chapter 12 contains part cleaning instructions. Appendix A contains a glossary of common terms and acronyms used throughout the manual; Appendix B provides torque specifications, and Appendix C contains maintenance standards.

1-1.1. Instructions for Continued Airworthiness

Continental Motors Part No. M-0, is supplemental, as defined by Title 14 CFR§33.4, to the maintenance and overhaul manuals listed below. Together, this manual and those listed below comprise the instructions for continued airworthiness for applicable engines. This manual, and the overhaul manuals and component service manuals (as applicable to engine specification) listed below are delivered to the customer with the engine. Service documents and Airworthiness Directives may also affect ICAs. Refer to Section 1-2.5 for instructions to check current publication status.

Part No.	Title	Applicability
M-2	Maintenance and Overhaul Manual	O-200-D, X
M-6	Maintenance and Overhaul Manual	IO-240
M-7	Maintenance and Overhaul Manual	IO-360
M-11	Maintenance Manual	IO-520 Permold
M-16	Maintenance and Overhaul Manual	IO-550 Permold
M-18	Maintenance and Overhaul Manual	TSIO-550 Permold



Introduction

M-22	Maintenance and Overhaul Manual	IOF-240
M-24	Maintenance Manual	IOF-550-A, B, C, G, N, P & R
M-26	Maintenance and Overhaul Manual	TSIOF-550
OH-15	Overhaul Manual	TSIOL-550-C
OH-24	Overhaul Manual	IOF-550
OMI-15	Operation, Maintenance and Installation Manual	TSIOL-550-C
X30008	Overhaul Manual	A-65, A-75
X30010	Overhaul Manual	C-75, C,85, C90, O-200-A, B
X30013	Overhaul Manual	C-125, C-145, O-300
X30016	Overhaul Manual	E-165, E-185, E-225
X30019	Overhaul Manual	GO-300
X30027	Overhaul Manual	IO-346
X30033	Overhaul Manual	TSIO-470
X30039	Overhaul Manual	IO-520
X30045	Overhaul Manual	GTSIO-520
X30144	Overhaul Manual	TIARA 6-285 and 6-320
X30531	Alternator Service Instructions	Continental alternators
X30571	Maintenance and Operator's Manual	TSIO-360-LB
X30574	Overhaul Manual	TSIO-520-B, BB, BE, D, DB, DB, E, EB, J, JB, K, KB, L, LB, N, NB, U, UB, VB, WB Permold series
X30575	Overhaul Manual	LTSIO-520-AE TSIO-520-C, CE, G, H, M, P, R, T, AE, AF Sandcast series
X30586	Overhaul Manual	O-470-A, B, E, G, J, K, L, M R, S, U
X30592	Starter Service Instructions	Energizer® starters
X30596	Overhaul Manual	LTSIO-360-EB, KB & RB, TSIO-360-A, AB, B, C, CB, D, DB, E, EB, F, FB, G, GB, H, HB, J, JB, K & KB, LB, MB, SB
X30596S1	Overhaul Manual	LTSIO-360-RB, TSIO-360-RB



X30600	Overhaul Manual	TSIOL-550-A
X30601	Maintenance and Operator's Manual	TSIOL-550-A
X30605	Maintenance Manual	IO-550-D, E, F & L
X30607	Overhaul Manual	IO-550-D, E, F & L
X30645	Maintenance Manual	LTSIO-360-RB TSIO-360-RB
X30672	Maintenance Manual	TSIO-360-MB, SB

1-1.2. Advisories

This manual utilizes three types of advisories; defined as follows:

WARNING

A warning emphasizes information which, if disregarded, could result in severe injury to personnel or equipment failure.

CAUTION: Emphasizes certain information or instructions, which if disregarded, may result in damage to the engine or accessories.

NOTE: Provides special interest information, which may facilitate performance of a procedure or operation of equipment.

Warnings and cautions precede the steps to which they apply; notes are placed in the manner which provides the greatest clarity. Warnings, cautions, and notes do not impose undue restrictions. Failure to heed advisories will likely result in the undesirable or unsafe conditions the advisory was intended to prevent. Advisories are inserted to ensure maximum safety, efficiency, and performance. Abuse, misuse, or neglect of equipment can cause eventual engine malfunction or failure.

1-1.3. Effectivity Symbols

Variations in engine configuration may require specific instructions or illustrations. When information pertains to only a subset of the applicable engine models, an effectivity symbol will precede the information. Effectivity symbols found in this publication are:

FWD Forward Mounted Gear Driven Alternator

AFT Aft Mounted Gear Driven Alternator

EZR Energizer Starter

SKY SkyTec Starter



1-1.4. Using this Manual

This manual, the primary engine ICA listed in Section 1-1.1, applicable FAA ADs and Continental Motors service documents, the accessory manuals listed in Table 1-2, and all changes incorporated in the ICAs as revisions constitute the Instructions for Continued Airworthiness (ICAs) prepared by Continental Motors and accepted by the FAA. We prepared this manual in a user-friendly format suited equally for electronic viewing and print. Illustrations in this manual are for reference only, depicting the most prominent configuration in the engine series. Consult the electronic illustrated parts catalog for engine model-specific illustrated parts breakdowns. The current information available from Continental Motors must be used to perform engine service, repair or overhaul.

Continental Motors provides Instructions for Continued Airworthiness based on the design, testing, and certification of engines and parts for which Continental Motors is the holder of the Type Certificate (TC) or Parts Manufacture Approval (PMA) issued by the Federal Aviation Administration (FAA).

WARNING

Continental Motors Instructions for Continued Airworthiness are applicable *only* to Continental Motors engines conforming to the approved, type certified engine model configuration. Continental Motors ICAs *must not* be used for aftermarket parts or products modified by Supplemental Type Certificate.

Installation of aftermarket parts on a Continental Motors engine constitutes a deviation from type-design criteria. Continental Motors has not participated in design, test, or certification of any aftermarket parts. Continental Motors does not provide product manufacturing specifications to aftermarket parts manufacturers and accepts no liability for the suitability, durability, longevity, or safety of such parts installed on Continental Motors engines. Installation of aftermarket parts on a Continental Motors engine must be performed using Instructions for Continued Airworthiness prepared by the manufacturer and approved by the FAA for the subject installation. For work with the engine installed in the aircraft, the aircraft maintenance manual may also be required to gain access to, perform maintenance, or install some items. Use only the current information from the aircraft manufacturer.

Exploded assembly illustrations accompany instructions throughout the manual. Parts in illustrations (Figure 1-1) are identified with either alpha or numerical callouts (indexes). Corresponding parts listings follow the illustrations for reference. The first time instructions refer to an illustration, the figure number is identified in parentheses, followed by the callout. In subsequent parts references, only the callout will be specified unless the referenced illustration changes.

Referenced illustration

1. Carefully slide the sleeve (Figure 6-15) 13 and drive gear assembly (12) out of the accessory drive adapter through the crankcase magneto pad opening.
2. Remove the nuts (10 & 11), lock washers (8 & 9) and washers (6 & 7). Remove the accessory drive assemblies from the rear of the crankcase. Discard the lock washers (8 & 9).
3. Remove and discard the gasket (1) and residue from the crankcase and the face of the accessory adapter.
4. Repeat steps 1 through 3 for the second accessory drive adapter.
5. Disassemble the accessory drive adapters according to instructions in Chapter 7.

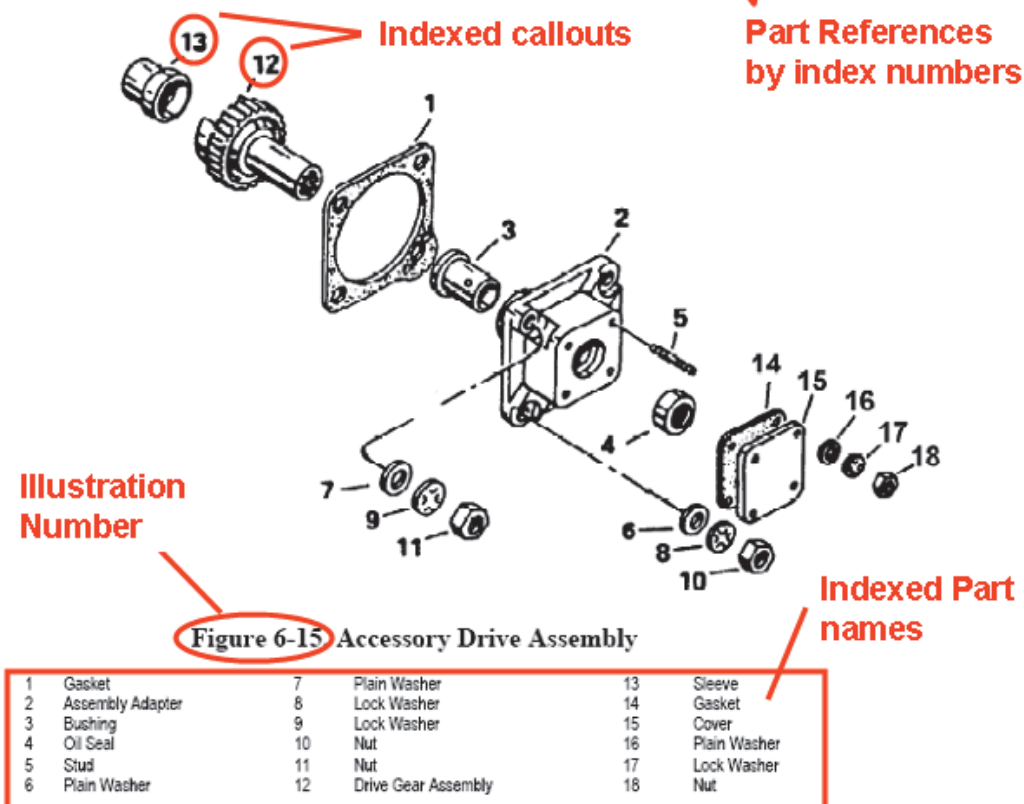

Figure 1-1. Figure and Index Reference



1-1.5. Compliance

The owner/operator is responsible for ensuring the engine is maintained in an airworthy condition, including compliance with FAA Airworthiness Directives. Engine service life is calculated based on compliance with the aircraft and engine manufacturer's required instructions, inspections, and maintenance schedule. Failure to comply may void the engine warranty.

WARNING

Prior to authorizing engine maintenance, the owner must ensure the facility or mechanic meets the Federal Aviation Administration (or equivalent authority) regulatory requirements. The engine owner must verify the repair facility or mechanic uses the most current revision, including change pages of the applicable ICA. Use of Instructions for Continued Airworthiness which have been designated as obsolete, superseded, or inactive is prohibited.

Continental Motors ICAs are written for use by maintenance personnel who possess and apply the knowledge, training, and experience commensurate with persons holding a valid license or certification granted by the governing airworthiness authority to return the engine to an airworthy condition. No other use is authorized.

WARNING

Failure to comply with ICAs may result in personal injury, death and subsequent engine failure. Each person performing maintenance, alteration or preventive maintenance on an engine or accessory must use methods, techniques and practices set forth in the Instructions for Continued Airworthiness or other methods, techniques, and practices found acceptable to the Administrator.

This manual shall be used in conjunction with the latest revision of FAA Advisory Circular 43.13-1, "Acceptable Methods, Techniques, and Practices" as well as related publications and accessory manufacturer's instructions. Pursuant to Title 14 CFR Part 43, §43.13(a), each person performing maintenance, alteration, or preventive maintenance on the engine or accessories must use methods, techniques, and practices prescribed in the ICAs or other methods, techniques, and practices found acceptable by the Administrator.



1-1.6. Order of Precedence

Continental Motors engine operating instructions are generated prior to and independently of the aircraft operating instructions. Continental Motors operating instructions are developed using factory controlled parameters that are not necessarily the same as those specifications required to satisfy a specific aircraft/engine installation.

WARNING

The aircraft operator must use the aircraft manufacturer's operating instructions found in the Airplane Flight Manual/Pilot's Operating Handbook (AFM/POH) and applicable Airplane Flight Manual Supplements (AFMS) while operating the engine in the aircraft unless the AFM/POH directs otherwise.

Refer to the AFM/POH published by the aircraft manufacturer for operating instructions and specifications relative to your aircraft.

Prior to commencing engine maintenance, consult the Continental Motors web site to verify the current status of the ICAs relating to the intended procedure.

1-2. Publications

This most current approved version of this manual is delivered to the customer at time of purchase. This manual and all subsequent revisions or changes are published in Adobe portable document (PDF) format and available for download on the Continental Motors Internet web site at <http://continentalmotors.aero>.

1-2.1. Publication Access

Printed technical publications may be ordered through authorized Continental Motors distributors or via the Internet at <http://www.continentalmotors.aero>. Contact an authorized Continental Motors distributor to discuss publication or service subscription options and pricing or visit our web site.

1-2.2. Publication Changes

WARNING

Use only the latest revision of all publications. Using superseded information may jeopardize engine airworthiness. Service documents, published by the manufacturer, or Airworthiness Directives, published by the FAA, may alter or provide supplemental information to the Maintenance and Overhaul Manual. Verify and use only the current versions of all instructions.

The instructions in this manual represent the best and most complete information available at the time of publication. Product or process improvements may trigger changes to existing product design specifications or procedures contained in publications. As new technical information becomes available, Continental Motors will make the information available to the customer.



Continental Motors releases publication changes in the form of either change pages or complete publication revisions, depending upon the extent of change.

Continental Motors issues service documents in the form of Service Bulletins on a wide variety of topics. Some service documents may affect or supplement information in this manual and should be reviewed prior to performing maintenance. All active service documents applicable to the Standard Practice have been incorporated in these instructions as of the date of publication.

1-2.3. Update/Change Distribution

Document updates are available on our web site upon notification of FAA document acceptance/approval. Printed publication subscribers receive printed changes and revisions as they are released.

...the first 25 hours of operation... required after engine installation, inspection, repairs, or adjustments. Follow these same parameters for the first 25 hours of operation to complete the recommended break-in for TCM engines.

New and rebuilt engines shipped by TCM are calibrated in a test cell prior to shipment. However, the flight check ensures the engine meets all operational parameters after installation and prior to release for normal service. Refer to "Engine Specifications and Operating Limits" in Chapter 2 specific limits for your engine model.

CAUTION: High power ground operation resulting in cylinder and oil temperatures exceeding normal operating limits can be detrimental to cylinders, pistons, valves, and rings.

1. Start the engine according to instruction in Section 7-3.2, "Engine Start."
2. Conduct a normal take-off according to instructions in Sections 7-3.3 "Engine Run-up before Takeoff", 7-3.4 "Taxi Preparation," and 7-3.5 "Take-Off."
3. Monitor the following engine operating indicators:
 - a. Engine RPM
 - b. FADEC HSA or ECP
 - c. Fuel flow
 - d. Oil pressure
 - e. Oil temperature
 - f. Cylinder Head Temperature
 - g. Turbine Inlet Temperature/Exhaust Gas Temperature
4. Reduce the engine speed to climb power in accordance with the airframe manufacturer's AFM/POH. Maintain a slow climb attitude to achieve optimum airspeed and cooling airflow.
5. At cruise altitude:
 - a. Maintain level flight cruise at 75% power for the first hour of operation.
 - b. During second hour of flight, alternate power settings between 65% and 75% power.

WARNING

Avoid long descents at high RPMs or low manifold pressure to prevent the engine from excessive cooling. If power must be reduced for long periods, adjust the propeller to minimum governing RPM and set the manifold pressure no lower than necessary to obtain desired performance.

7-14
Change 2

IOF-550 Permold Series Engine Installation and Operation Manual
1 March 2008

Figure 1-2. Change Page Identification



Document revisions are released if the update changes more than 50% of the contents of a publication. Revisions replace the previous version of a publication from cover to cover. Minor corrections are released as change pages to the original publication, identified with a change number and effective change date in the page footer. Information on the page that changed from the previous edition is identified by a vertical, six-point black line (Figure 1-2), referred to as a “change bar” in the outside margin of the page.

A change page replaces only the previous edition of the affected page. In the event a change page forces repagination, a new page will be inserted with a decimal extension added to the page number. For example, if additional pages are required between pages 1-6 and 1-7, the inserted page numbers will be 1-6.1, 1-6.2, and so on until sufficient pages are added to incorporate the new material.

Page A of the manual contains the original publication date and an itemized list of changes issued for the technical manual (Figure 1-3). If change pages are issued for the manual, the change will be identified, with an effective date under the heading “Effective Changes for This Manual” on Page A. The list of effective pages, itemizes the pages in each section, by change number. Original pages are designated by a 0 in the List of Effective Pages “Change” column.

Supersedure Notice
 This manual is a revision of the IOF-550-B, C, N, P and R Permoloid Series Engine Installation Manual (OI-24), dated 1 Feb 2007. All previous versions are obsolete upon release of this publication.

Effective Changes for this Manual

0 1 Apr 2007
 1 12 Oct 2007
 2 1 Mar 2008

List of Effective Pages
 Document Title: IOF-550 Permoloid Series Engine Installation
 Publication Number: OI-24

Page.....Change	Page.....Change	Page.....Change	Page.....Change
Cover & II2	5-10 thru 5-44.....0		
II-III0	6-1 thru 6-8.....0		
1-1 thru 1-80	7-1 thru 7-2.....2		
2-1 thru 2-200	7-3 thru 7-4.....0		
2-21.....2	7-5 thru 7-7.....2		
2-22 thru 34.....0	7-8 thru 7-10.....0		
2-35.....2	7-11 thru 7-12.....2		
2-36-2-420	7-13.....0		
3-1 thru 3-20	7-14.....2		
4-1 thru 4-32	7-15 thru 7-16.....0		
4-4.....0	7-17 thru 7-54.....2		
4-5.....2	A-1 thru A-6.....0		
4-6 thru 4-130	B-1 thru B-12.....0		

Effective Manual Changes and Change Dates

Itemized List of Effective Pages

Figure 1-3. List of Effective Pages



1-2.4. Service Documents

Continental Motors may issue Service Documents in one of six categories ranging from mandatory (Category 1) to informational (Category 6). Definitions of the categories are listed below:

NOTE: Upon FAA approval, Continental Motors publishes service documents for immediate availability on our web site. The service document cover page indicates the engine models affected by the service document. Service documents may alter or replace the manufacturer's Instructions for Continued Airworthiness. Insert a copy of applicable Service Documents in affected manuals until the service document instructions are incorporated in the manual, or the service document is canceled or superseded.

Category 1: Mandatory Service Bulletin (MSB)

Used to identify and correct a known or suspected safety hazard which has been incorporated in whole or in part into an Airworthiness Directive (AD) issued by the FAA or have been issued at the direction of the FAA by the manufacturer requiring compliance with an already-issued AD (or an equivalent issued by another country's airworthiness authority). May contain updates to Instructions for Continued Airworthiness to address a safety issue.

Category 2: Critical Service Bulletin (CSB)

This category identifies a condition that threatens continued safe operation of an aircraft, persons or property on the ground unless some specific action (inspection, repair, replacement, etc.) is taken by the owner or operator. Documents in this category are candidates for incorporation into an FAA Airworthiness Directive. May contain updates to Instructions for Continued Airworthiness to address a safety issue.

Category 3: Service Bulletin (SB)

Information which the product manufacturer believes may improve the inherent safety of an aircraft or aircraft component; this category includes the most recent updates to Instructions for Continued Airworthiness.

Category 4: Service Information Directive (SID)

The manufacturer directs the owner/operator/mechanic in the use of a product to enhance safety, maintenance or economy. May contain updates to Instructions for Continued Airworthiness in the form of maintenance procedures or specifications.

Category 5: Service Information Letter (SIL)

This category includes all information (not included in categories 1 through 4) that may be useful to the owner/operator/technician. May contain updates to Instructions for Continued Airworthiness for optional component installations, which are not covered in the Applicable Operator, Maintenance, or Overhaul Manuals.

Category 6: Special Service Instruction (SSI)

This category is used to address an issue limited to specific model and/or serial number engines. We will distribute SSI notification directly to the affected engine's owners. SSIs will not be included in the general service document set but will be made available through our Customer Service Department to owners of the affected engines only. An SSI may update the applicable engine's Instructions for Continued Airworthiness.



1-2.4.1. Service Documents Incorporated in this Manual

Applicable technical maintenance and service information contained in the Service Documents listed below, relevant to the engine models covered by this engine manual, have been incorporated in this M-0 Standard Practice Maintenance Manual. This manual supersedes and retires these older Service Documents (where applicable) excluding Mandatory Service Bulletins (MSBs) and Critical Service Bulletins (CSBs) identified with an asterisk below.

The full content of active Continental Motors Service Documents is available at www.continentalmotors.aero. Refer Section 1-3, “Contact Information” for Continental Motors web site details.

Table 1-1. Service Documents Incorporated in Manual

Service Document	Subject	Affected Chapter
M67-12, Overboost of Turbocharged Engines	Unscheduled Maintenance	6
M72-17R1, Maximum Weight Difference Between Connecting Rods and Pistons in the Same Engine	Parts Replacement	10
M76-4, Propeller Shaft or Crankshaft Oil Seal Replacement	Unscheduled Maintenance	10
M76-8, Intake Valve Change	Unscheduled Maintenance	10
M77-3, Use of Alternate Fuels in Engines Originally Certified for 80/87, 91/96 and 100/130 Grade Fuels	Engine Operation	7
M84-5, Gear Driven Alternator Inspection Procedure	Alternator Replacement	10
M87-15, Alternator Ground Strap	Alternator Replacement	10
M88-9, Lightning Strikes	Unscheduled Maintenance	6
M88-10, Contaminated Fuels	Unscheduled Maintenance	6
M89-7R1, Engine Operation after Cylinder Replacement and/or Major Overhaul	Unscheduled Maintenance	7
M89-9, Excessive Crankcase Pressure	Unscheduled Maintenance	8
M90-17, Crankcase Inspection Criteria	Scheduled Maintenance	6
SIL93-11B, Service Document Format	Service Documents	1
SIL93-15, General Practices for Installation of Lock Wire, Tab Washers, and Cotter Pins	Standard Practices	Appendix C
* MSB94-8D, Magneto to Engine Timing	Scheduled Maintenance	6
SB95-2, Inspection and Maintenance of Engine Control Cables and Linkage	Inspection	6
SB95-3B, Alternator/Generator Drive Coupling	Alternator Maintenance	6, 10
SIL95-5, Hose and Tubing Installation	Hose and Tubing installation	Appendix C
SB96-7D, Torque Limits	Fastener Torque	Appendix B
* MSB96-10B, Crankshaft Ultrasonic Inspection	Engine Overhaul or Crankshaft Repair	10
SB96-11B, Propeller Strikes and Hydraulic Lock	Unscheduled Inspection	6



Introduction

Table 1-1. Service Documents Incorporated in Manual

Service Document	Subject	Affected Chapter
SB96-12, Cylinder Continued Airworthiness	Scheduled Inspection	6 & 10
SID97-2B, Design, Operation Maintenance and Warranty of Cylinders	Engine Maintenance	6
SID97-3G, Continuous Flow Fuel Injection Systems Adjustment Specifications and Instructions	Operational Checks and Adjustments	6
SID97-4F, Cylinder Bore and Piston Fit Specifications	Overhaul & Service Limits	10
SB97-6B, Mandatory Replacement Parts	Engine Inspection & Assembly	Appendix C
SIL98-9E, Time Between Overhaul Periods	Scheduled Maintenance	6
SIL99-1, Engine Preservation for Active and Stored Aircraft	Engine Preservation and Recovery	9
SIL99-2C, Sealants, Lubricants and Adhesives Authorized by CMI	Materials	3
SB00-3A, Crankshaft, Counterweight and Connecting Rod Repair Information	Repair Specifications	10
SIL00-9A, Engine Data Plates	Data Plate Replacement	Appendix C
SIL00-11B, Release of new Cylinder Induction Port Drain Connector	Cylinder Assembly	10
SIL03-1, Cold Weather Operation - Engine Preheating	Engine Operation	7
SIL03-2C, Currently Active Approved Spark Plug Application	Spark Plugs	6
SB03-3, Differential Pressure Test and Borescope Inspection	Inspection Criteria	6
SIL04-12A, Authorized Engine Adjustments, Component Replacement and Repositioning	Engine Specification	5
SB05-2, Overspeed Limitations	Unscheduled Maintenance	6
* CSB08-3C, Throttle & Mixture Control Levers	Fuel Injection System Assembly	6
SB08-13, Induction System Hose and Clamp Installation	Induction System Inspection & Assembly	6
SB11-3, Alternator and Drive Coupling Installation	Alternator Replacement	6, 10
SIL13-2A, Alternator Instructions for Continued Airworthiness	Alternator Replacement	6, 10
SB14-8, Exhaust Flange to Cylinder Installation	Exhaust System Installation	10
SB16-3, Turbocharger Check Valve Inspection and Cleaning	Exhaust System Inspection	6

* Documents remain active in the service bulletin set.



1-2.4.2. Service Documents Released After Publication

Continental Motors strives to provide clear, concise, and accurate information and instructions based on best known engineering data at the time of publication. Ongoing process improvements may change a specification or procedure after a manual is released. Service documents, defined in Section 1-2.4, expedite customer notification until the new information is incorporated in the manual text. As service documents are received, note the service document number, release date, title, and applicable section affected by the service document in the blank cells below and insert a copy of the service document behind the last page of this section. Make pen & ink corrections, where appropriate, to the original text in the manual with a citation to the service document; i.e. see SB9X-1. For paragraphs or entire sections, draw an “X” through the affected information in the manual and reference the service document containing the correction

Service Documents Release After This Manual

Document Number:	_____	Release Date:	____/____/____	Affected Sections:	_____
Title:	_____				
Document Number:	_____	Release Date:	____/____/____	Affected Sections:	_____
Title:	_____				
Document Number:	_____	Release Date:	____/____/____	Affected Sections:	_____
Title:	_____				
Document Number:	_____	Release Date:	____/____/____	Affected Sections:	_____
Title:	_____				
Document Number:	_____	Release Date:	____/____/____	Affected Sections:	_____
Title:	_____				
Document Number:	_____	Release Date:	____/____/____	Affected Sections:	_____
Title:	_____				
Document Number:	_____	Release Date:	____/____/____	Affected Sections:	_____
Title:	_____				
Document Number:	_____	Release Date:	____/____/____	Affected Sections:	_____
Title:	_____				
Document Number:	_____	Release Date:	____/____/____	Affected Sections:	_____
Title:	_____				



Introduction

Service Documents Release After This Manual

Document Number: _____ Release Date: ____/____/____ Affected Sections: _____

Title: _____

Document Number: _____ Release Date: ____/____/____ Affected Sections: _____

Title: _____

Document Number: _____ Release Date: ____/____/____ Affected Sections: _____

Title: _____

Document Number: _____ Release Date: ____/____/____ Affected Sections: _____

Title: _____

Document Number: _____ Release Date: ____/____/____ Affected Sections: _____

Title: _____

Document Number: _____ Release Date: ____/____/____ Affected Sections: _____

Title: _____

Document Number: _____ Release Date: ____/____/____ Affected Sections: _____

Title: _____

Document Number: _____ Release Date: ____/____/____ Affected Sections: _____

Title: _____

Document Number: _____ Release Date: ____/____/____ Affected Sections: _____

Title: _____

Document Number: _____ Release Date: ____/____/____ Affected Sections: _____

Title: _____

Document Number: _____ Release Date: ____/____/____ Affected Sections: _____

Title: _____

Document Number: _____ Release Date: ____/____/____ Affected Sections: _____

Title: _____

Document Number: _____ Release Date: ____/____/____ Affected Sections: _____

Title: _____

Document Number: _____ Release Date: ____/____/____ Affected Sections: _____

Title: _____

Document Number: _____ Release Date: ____/____/____ Affected Sections: _____

Title: _____



1-2.5. Related Publications

The table below lists the publications, source, and accessibility relevant to Standard Practice installation, maintenance and overhaul.

WARNING

Use only the latest revision of all publications. Using superseded information jeopardize engine airworthiness.

Table 1-2. Related Publications

Publication	Supplied With Engine	Internet via Continental Motors web site ¹	Printed Manual Available for Purchase
Instructions for Continued Airworthiness			
Standard Practice Maintenance Manual (M-0) (this manual)	Yes	Yes	Yes
Starter Service Instructions (X30592)	Yes	Yes	Yes
Alternator Service Instructions (X30531)	Yes	Yes	Yes
Magneto Service Manual (X42002)	Yes	Yes	Yes
Illustrated Parts Catalogs			
Electronic Engine Product Catalog (by Engine Model and Specification)	No	Yes (view only)	No

1. Our web site (continentalmotors.aero) provides daily 24-hour access to engine technical data via the Internet. If you are an Internet service subscriber, you can access our web site to confirm and review the latest revision of this manual. If you have not subscribed to our Internet service and are using printed manuals, contact a service representative using the "Contact Information" in Section 1-3 to confirm you have the latest revision of the manual.

1-2.5.1. Suggestions and Corrections

Continental Motors solicits and encourages user comments regarding suggested changes to this manual. Direct recommended changes or questions to the attention of "Publications" at the address listed in Section 1-3, "Contact Information" or send comments via e-mail to CM.techpubs@continentalmotors.aero.

Notify our Customer Service Department immediately if you discover incorrect information which adversely affects safety.



1-3. Contact Information

Continental Motors factory representatives are available to answer technical questions and encourages suggestions regarding products, parts, or service. If customers have an inquiry or require technical assistance, they should contact their local Continental Motors distributor or field representative. To contact a factory representative, refer to the contact information below:

Continental Motors
P. O. Box 90
Mobile, AL 36601

Customer Service Department:

Toll free within the Continental United States: 1-888-826-5465

International: 1-251-438-8299

Internet: www.continentalmotors.aero.

1-4. Service Parts

Continental Motors engineering staff develops a complete bill of materials for every engine model specification manufactured. Due to our diverse customer base of aircraft OEM and STC application builders, engine model specifications are developed to accommodate the aircraft manufacturer's specifications. While many parts fit multiple engine model specifications, interchangeability of parts from one engine model, or model specification, to another is not guaranteed.

1-4.1. Service Part Applicability and Availability

Major engine assemblies and components are permanently identified (steel stamped, engraved, laser etched, or ink-stamped) with a unique part number during the manufacturing process. An electronic parts catalog for all current production engine model specifications is available on the Continental Motors web site (see Section 1-3). For Continental Motors' heritage products, no longer in production, copies of the last revision of printed illustrated parts catalogs are available on-line in portable document format.

Some parts of assemblies are not available for aftermarket sale for various reasons. Some assemblies are not intended to be disassembled, such as cylinder heads and barrels. For this reason, only the next higher assembly (NHA) is available for aftermarket sales.

1-4.2. Part Supersedure

One of Continental Motors engineering core values is continuous improvement. The original part numbers used to manufacture your aircraft engine may or may not be available at the time replacement parts are necessary to restore the engine to an airworthy condition. The simplest way to determine the part number required is to locate the part or assembly in the illustrated parts catalog and compare part number(s) to the markings on the existing part(s). Through design improvements, it may be necessary to assign a new part number to a part or assembly that supersedes the part number used to build earlier specifications of your engine model because the form, fit or function of the parts differ.

To determine if a part number used to assemble your engine has been superseded, consult the Parts Supersedure History under the Support Materials heading on our web site.



Chapter 2. Tools

2-1. Special Tools

NOTE: Tools listed in Table 2-1 are for reference only, not for the purpose of promoting a particular vendor or requiring the customer to purchase from the indicated sources. The providers listed are potential sources for the items based on information available at the time of printing. Customers are free to obtain equivalent items from alternate sources which meet or exceed specifications of the listed tools. For FADEC special tools, reference the primary ICA.

Special tool provider contact information is listed in Table 2-2.

Table 2-1. Special Tools List

Special Tool	Use or Reference	Suggested Providers	Part Number
Maintenance			
0-60 psi Pressure Gauge (graduated in 1-psi increments)	Engine Operational Check	Davis Instruments	Various
0-30 psi Pressure Gauge (graduated in 0.2-psi increments)	Engine Operational Check (normally aspirated engines only)	Davis Instruments	Various
0-30 psid Differential Pressure Gauge (graduated in 0.2 psi increments)	Engine Operational Check (turbocharged engines only)	Davis Instruments	Various
Alternator Drive Hub Spanner Wrench	Forward Mounted Alternator Drive Hub Assembly Inspection	Ideal Aviation	9001-IA
Alternator Drive Hub Torque Tool	Forward Mounted Alternator Drive Hub Slippage Inspection	Fabricate according to Figure 2-5	---
Alternator Drive Hub Torque Tool	Aft Mounted Alternator Drive Hub Slippage Inspection	Fabricate according to Figure 2-6	---
Bearing Installation Tool (Worm Gear Roller Bearing)	90° offset Starter Adapter Assembly	Fabricate according to Figure 2-15	---
Belt Tension Gage	Drive Belt Tension Adjustment	Ideal Aviation	BT-33-73FIA
Borescope	Cylinder Borescope Inspection	Q.A. Technologies	AUTOSCOPE™ Lenox Instrument Company
Differential Pressure Tester	Cylinder Differential Pressure Test	Eastern Technology Corporation	Model E2M
Digital Multimeter	Troubleshooting	Commercial, off the shelf	---
High Tension Lead Test Kit	Ignition Harness Troubleshooting	Eastern Technology Corporation	E5
7/16" Injector Nozzle Removal/Installation Tool	Fuel Injector Removal And Installation	Ideal Aviation	8167-IA



Tools

Table 2-1. Special Tools List

Special Tool	Use or Reference	Suggested Providers	Part Number
1/2" Injector Nozzle Removal/Installation Tool	Fuel Injector Removal And Installation	Ideal Aviation	8168-IA
Oil Filter Can Cutter	Cut Oil Filter Can	Champion Aerospace	CT-923
Oil Filter Torque Wrench	Oil Filter Installation	Champion Aerospace	CT-921
Porta-Test Unit	Engine Operational Check	Approved Aircraft Accessories	Model 20 ATM-C
Portable Digital EGT/CHT Tester	Verify EGT/CHT/TIT Accuracy	Alcor, Inc.	ALCAL 2000
Protractor/Timing Indicator Disc and TDC Locator	Engine Timing	Eastern Technology Corporation	E25
Pulley Alignment Tool	Belt Drive Pulley Alignment	Ideal Aviation	8082-IA
Pulley Puller	Remove Generator/Alternator Sheave	Ideal Aviation	61-5IA
Timing Light	Magneto to Engine Timing	Eastern Technology Corporation	E50
Worm Shaft Tool & Starter Adapter Disassembly Tool	Starter & Starter Adapter Disassembly	Fabricate according to Figure 2-7	---
Overhaul			
Bearing Puller	Component Maintenance	Borroughs***	8093C
Boring Bars	Cylinder Repair	Borroughs***	8116-1B through -15B
Carbide Tipped Reamer	Valve Guide Reaming	Kent-Moore***	2847-2CP 2847-1CP
Common Drive Handle	Cylinder Repair	Borroughs***	8122A
Common Parts Kit	Valve Seat Replacement	Borroughs***	8116
Connecting Rod Boring & Alignment Fixture	Connecting Rod Piston Bushing Replacement	Borroughs***	8111A
Connecting Rod Bushing Removal/Installation Set	Connecting Rod Piston Bushing Replacement	Borroughs***	8098
Connecting Rod Bushing Installation and Removal Tool Adapter Kit	Connecting Rod Piston Pin Bushing Replacement	Borroughs***	8042C
Connecting Rod Bushing Reamer	Connecting Rod Bushing Bore Honing	Kent-Moore***	5008
		Borroughs***	8071
Contact Profilometer	Cylinder Bore Honing	Commercial, off the shelf	N/A
Counterweight Bushing Remover/Replacer Tool	Counterweight Hanger Blade Bushing Replacement And Counterweight Bushing Replacement	Borroughs***	4965A



Table 2-1. Special Tools List

Special Tool	Use or Reference	Suggested Providers	Part Number
Crankcase Needle Bearing Installer Tool	Crankcase Assembly	Fabricate according to Figure 2-16 (Permold) Figure 2-17 (Sandcast)	---
Crankcase Splitter	Separate The Crankcase	Kent-Moore***	L423
Crankcase Through Bolt Remover	Crankcase Disassembly	Borroughs***	8114-8
Crankshaft Counterweight Bushing Removal/Installation Fixture	Crankshaft Overhaul	Borroughs***	8077C
Crankshaft Hanger Blade Bushing Removal/Installation Tool	Crankshaft Overhaul	Borroughs***	8077A
Crankshaft Nose Oil Seal Installer Tool	Crankshaft Nose Oil Seal Installation <i>Not require for split type nose oil seals</i>	Kent-Moore***	5209
Cylinder Base Nut Wrenches	Cylinder Maintenance	Kent-Moore***	5203, 5204, & 8158A, 3882, & 3882-2
		Borroughs***	8079
Cylinder Heating Stand	Cylinder Maintenance	Borroughs***	8156
Cylinder Holding Fixture	Valve Seat Replacement Valve Guide Replacement Valve Seat Machining	Borroughs***	5221B
Cylinder Holding Fixture Adapters	Valve Seat Replacement Valve Guide Replacement Valve Seat Machining	Borroughs***	5221-13A 5221-15A 5221-16A
Cylinder Hone	Engine Cylinder Bore Honing	Snap On Tools	CFL10
Dial Indicator	Gear Backlash Measurement	Commercial, off the shelf	---
Exhaust Valve Seat Grinding Stone (Roughening 45°)	Valve Seat Machining	Aircraft Tool Supply	K95
Exhaust Valve Seat Grinding Stone (Finishing 45°)	Intake Or Exhaust Valve Seat Machining	Aircraft Tool Supply	K25
Expanding Guide Bodies	Valve Guide Replacement	Borroughs***	8116-1 through -16
Generator Drive Holder	Secure The Generator Drive	Borroughs***	4973
Heli-Coil Extracting Tool	Helical Coil Insert Replacement	Stanley Engineered Fastening	---
Heli-Coil Installation Tool	Helical Coil Insert Replacement	Stanley Engineered Fastening	---
Heli-Coil Expanding Tool No. 520-2	Helical Coil Insert Replacement	Stanley Engineered Fastening	520-2
High Speed Steel Reamer	Reaming Valve Guides	Kent-Moore***	2847-1HP 2847-2HP



Tools

Table 2-1. Special Tools List

Special Tool	Use or Reference	Suggested Providers	Part Number
Intake Valve Seat Grinding Stone (Roughening 30°)	Valve Seat Machining	Aircraft Tool Supply	K106
Intake Valve Seat Grinding Stone (Finishing 30°)	Valve Seat Machining	Aircraft Tool Supply	K46
Needle Bearing Installer Tool	Starter Adapter Housing Worm Shaft Needle Bearing Replacement	Borroughs***	23-1
O-ring Installation Tool	Crankcase Hardware Installation	Fabricate according to Figure 2-19	---
Oil Control Plug Installation Tool	Oil Control Plug Replacement	Fabricate according to Figure 2-10 through Figure 2-11	---
Oil Control Plug Leak Test Fixture	Oil Control Plug Replacement	Fabricate according to Figure 2-12	---
Oil Pressure Relief Spot Facer	Oil Pressure Relief Valve Seat Refacing	Kent-Moore***	8048
Oil Seal Tool	Crankcase And Accessory Drive Adapter Oil Seal Installation	Fabricate according to Figure 2-20	---
Piston Ring Compressor	Engine Cylinder Installation	Kent-Moore***	3601
Piston Ring Removers	Piston Ring Removal	Kent-Moore***	8121
Polishing Tool	Engine Drive Train Inspection	Burroughs***	8087B
Pushrod Spring Compressor Tool	Pushrod Installation	Kent-Moore	68-3
Reamers	Valve Guide Reaming	Borroughs***	8116-1R through -15R
Reamer, Adjustable Blade	Magneto Drive Adapters Bushing And Oil Seal Installation	Borroughs***	Size range 25132-27132
Rocker Arm Bushing Remover/Installer	Rocker Arm Bushings (Single-Bushing Type) Replacement	Kent-Moore***	8118
Rocker Arm Bushing Reamer	Ream Rocker Arm Bushing	Kent-Moore***	7232
Rosan® Stud Remover	Remove Rosan Studs	McMaster-Carr Supply Company	2769A13
Rosan® Lock Ring Installer	Rosan Studs Installation	Kent-Moore***	8074
Spark Plug Insert Remover	Spark Plug Heli-coil Insert Removal	Borroughs***	4919
Spark Plug Insert Replacer	Spark Plug Heli-coil Insert Installation	Borroughs***	4918
Spark Plug Tap (18 mm)	Repair Damaged Spark Plug Threads/Boss	Borroughs***	445
Test Club	Post-Overhaul Testing	Hartzell Propeller, Inc.	
Valve Guide Boss Reamers	Valve Guide Reaming	Kent-Moore***	4943-1 HS through -5HS



Table 2-1. Special Tools List

Special Tool	Use or Reference	Suggested Providers	Part Number
Valve Guide Seal Installation Tool	Valve Guide Seal Installation	Fabricate according to Figure 2-18	---
Valve Seat Grinder Set "Sioux Brand"	Machining Intake Or Exhaust Valve Seat	Aircraft Tool Supply	1675
Valve Seat Grinder Pilot 0.437 diameter	Machining Intake Or Exhaust Valve Seat	Aircraft Tool Supply	AEX 437
Valve Seat (Straight Side) Insert Cutters	Valve Seat Repair	Kent-Moore***	5224 & 5225
Valve Seat (Step Side) Insert Cutters	Valve Seat Repair	Kent-Moore***	8135, 8136, & 8138
Valve Seat Insert Remover & Replacer	Valve Seat Replacement	Borroughs***	8086
Valve Spring Compressor Tool	Engine Cylinder Assembly	Kent-Moore***	3602
Overhaul Inspection			
Contour Probe	Magnetic Particle Inspection	Parker Research Corporation	DA-200
Federal Dimension Air Gage (with setting ring and air plug) or equivalent with 1.1268 Setting Ring 1.1268 Air Plug	Counterweight Hanger Blade Bushing Replacement Counterweight Bushings Replacement	MAHR Federal	D-4000
Dial Bore Gauges	Cylinder Bore Inner Diameter Dimensional Inspection	MAHR Federal	545-116
Plug Gauge	Cylinder Intake Valve Guide Inspection	Kent-Moore***	2848-1
Ultrasonic Test Instrument, Portable	Crankshaft Ultrasonic Inspection	Krautkramer-Branson	Krautkramer-Branson P/N: USK 7D OR7S USL 42 USL 48 USN 50 USN 52
Ultrasonic Test Instrument Calibration Block	Crankshaft Ultrasonic Inspection (Equipment Calibration)	Krautkramer-Branson	DSC Block or Rompas Block (steel)
Coaxial Cable - Grade 74 RG174/U 50 ohm Microdot to BNC (6')	Crankshaft Ultrasonic Inspection (For Connecting The Transducer To The Ultrasonic Equipment)	Krautkramer-Branson	Krautkramer-Branson P/N 118140012
Coaxial Cable MMD to BNC (6')	Cylinder Barrel Ultrasonic Inspection	Krautkramer-Branson	Krautkramer-Branson P/N C-047
Filter (microhenry BNC to BNC)	Cylinder Barrel Ultrasonic Inspection	Krautkramer-Branson	Krautkramer-Branson P/N 281-678-200



Tools

Table 2-1. Special Tools List

Special Tool	Use or Reference	Suggested Providers	Part Number
Fixture 60° Axial	Cylinder Barrel Ultrasonic Inspection	Krautkramer-Branson	Krautkramer-Branson P/N 291-678-000
Flaw Detector	Cylinder Barrel Ultrasonic Inspection	Krautkramer-Branson	Krautkramer-Branson P/N USL-42 or equivalent
Transducer 5.0 MHz, 0.125 diameter	Cylinder Barrel Ultrasonic Inspection	Krautkramer-Branson	Krautkramer-Branson P/N SMSWS 113-214-585
Transducer, Miniature (Gamma Series 5 MHz)	Crankshaft Ultrasonic Inspection (Provide Piezoelectric Effect)	Krautkramer-Branson	Krautkramer-Branson P/N MSWS 224-580
Crankshaft Main Bearing 2.2375 – 2.2485 inches (5.6833 – 5.7112 cm) and	Crankshaft Ultrasonic Inspection	Continental Motors	654478-1
Miniature Wedge (45° shear wave)	Crankshaft Ultrasonic Inspection	Continental Motors	654484
Crankshaft Main Bearing 2.3630 – 2.3750 inches (6.0020 – 6.0325 cm) and	Crankshaft Ultrasonic Inspection	Continental Motors	654483-1
Miniature Wedge (45° shear wave)	Crankshaft Ultrasonic Inspection	Continental Motors	654578
Crankshaft Main Bearing 2.6140 – 2.6250 inches (6.6396 – 6.6675 cm) and	Crankshaft Ultrasonic Inspection	Continental Motors	654485-1
Miniature Wedge (45° shear wave)	Crankshaft Ultrasonic Inspection	Continental Motors	654484
Micrometers (series 3 point contact inside micrometers)	Counterweight Hanger Blade Bushing Replacement	Starrett	No. 78
Runout Block Set	Drive Train Dimensional Inspection	Borroughs***	8117a
*or equivalent			
**Providers can be subject to change or discontinue manufacturing tools			
*** The rights to manufacture Borroughs and Kent-Moore tools has been acquired by Kell-Strom Tool Company.			



2-1.1. Vendor Contact Information

NOTE: Items with Continental Motors part numbers may be purchased directly from Continental Motors.

Table 2-2. Tools, Accessories, and Supply Vendors

Supplier	Address	Phone	FAX	Web Address ¹
American Lubricants / Moly Motor Oil	1227 Deeds Dayton, OH 45401	937-222-2851	618-534-5231	molymotoroil.com
Aircraft Tool Supply	P.O. Box 370 1000 Old U.S. 23 Oscoda, MI 48750	800-248-0638 517-739-1447	517-739-1448	aircraft-tool.com
Alcor	300 Breesport San Antonio, TX 78216	800-343-7233 210-349-6491	210-308-8536	alcorinc.com
Approved Aircraft Accessories	8545 Groh Road Grosse Ile, MI 48138	734-675-0278	N/A	N/A
A. W. Chesterton Company	500 Unicorn Park Drive Woburn, MA 01801-3345	800-835-4135 781-438-7000	781-438-8971	chesterton.com
ASTM	100 Barr Harbor Drive West Conshohocken, PA 19428	877-909-2786 610-832-9585	N/A	astm.org
Borroughs	See Kell-Strom Tools			
Champion Aerospace, Inc.	1230 Old Norris Road Liberty, SC 29657	864-843-1162	864-843-5402	championaerospace.com
CRC Industries/Chemical Products	885 Louis Drive Warminster, PA 18974	800-272-4620 800-556-5074	800-272-4560 215-674-2196	crcindustries.com
Davis Instruments	625 E. Bunker Ct. Vernon Hills, IL 60061	800-358-5525		inotek.com davis.com
Daubert Chemical	4700 South Central Ave Chicago, IL 60638	708-563-8325	78-496-7367	daubertchemical.com
Dow Corning Corporation	P.O. Box 997 South Saginaw Road Midand, MI 48686	989-496-4400 800-662-0661		dowcorning.com
Eastern Electronics	See Eastern Technology Corporation			
Eastern Technology Corporation	42 Nelson St. East Hartford CT 06108	860-528-9821	860-289-7639	easterntech.com
Federal Mogul	Southfield, MI	248-354-7700		federal-mogul.com
Graham Aircraft Engines (Motorstor)	PO Box 3214 Peachtree City, GA 30269	770-252-4995	770-252-5270	www.highaero.com
Hartzell Engine Technologies (formerly Kelly Aerospace)	Power Systems 2900 Selma Hwy Montgomery, AL 36108	877-359-5355	334-386-5410	hartzellenginetechnology.com
Hartzell Propeller Inc.	One Propeller Place Piqua, OH 45356	937-778-4200	937-778-4271	hartzellprop.com
Henkel Aerospace	32100 Stephenson Hwy Madison Heights, MI 48071	248-583-9300	248-583-2976	henkel.com
Ideal Aviation	564 Juanita Avenue Mesa, AZ 85204	480-963-8890	480-963-8887	idealaviation.com



Tools

Table 2-2. Tools, Accessories, and Supply Vendors

Supplier	Address	Phone	FAX	Web Address ¹
Kell-Strom Tool Company	214 Church Street Wethersfield, CT 06109	800-851-6851 860-529-6851	860-257-9694	kell-strom.com
Kent-Moore	See Kell-Strom Tool Company			
Krautkramer-Branson	50 Industrial Park Road Lewistown, PA 17044	717-242-0327 334-438-3411		metrologyworld.com/ storefronts/ krautkramer.html
Loctite	1001 Trout Brook Crossing Rocky Hill, CT 06067-3910	860-571-5100 800-243-4874	860-571-5465	loctite.com
LPS Laboratories	4647 Hugh Howell Road Tucker, GA 30084	800-241-9334 770-243-8800	770-243-8899	lpslabs.com
Lubriplate	129 Lockwood St. Newark, NJ 07105	973-589-9150 800-733-4755	973-589-4432	lubriplate.com
MAHR Federal	1144 Eddy Street Providence, RI 02905	401-784-3271 800-343-2050	401-784-3246	mahr.com
McMaster-Carr Supply Company	P.O. Box 4355 Chicago, IL 60680-4355	630-833-0300	630-834-9427	mcmaster.com
Merit Abrasives	201 W. Mansville Dr. Compton, CA 90224	800-421-1936 310-639-4242	800-472-3094	meritabr.com
Miller-Stephenson Chemical Company	6348 Oakton St. Morton Grove, IL 60053	847-966-2022 800-992-2424	847-966-8468	miller- stephenson.com
Q.A. Technologies	P.O. Box 61085 Savannah, GA 31420	912-330-0500	912-330-0104	gatek.com
Parker Research Corporation	P.O. Box 1406 Dunedin, FL 34697	800-525-3935 727-796-4066	727-797-3941	parkreascorp.com
Shell Oil Company	P.O. Box 2463 Houston, TX 77252	713-241-4819 800-332-6457	713-241-6511	shell-lubricants.com
Snap On (Tools)		877-740-1900	877-740-1880	snapon.com
Stanley Engineered Fastening	4 Shelter Rock Lane Danbury, CT 06810	877-364-2781	800-225-5614	stanleyengineeredfastening.com
L.S. Starrett Company	121 Crescent Street Athol, MA 01331	800-541-8887 978-249-3551	978-249-8495	starrett.com
Tanair (Tanis Aircraft Services)	P14871 Pioneer Trail Suite. 200 Eden Prairie, MN 55347	800-443-2136 In Minnesota: 952-224-4425	952-224-4426	tanisaircraft.com
U.S. Industrial Tool & Supply	14083 South Normandie Ave. Gardena, CA 90249	310-464-8400 800-464-8400	310-464-8880	ustool.com
Worldwide Filter (Mouse Milk)	1689 Abram Court San Leandro, CA 94577	510-483-5122	734-455-3256	mousemilk.com

1. Unless otherwise indicated, type <http://www>. followed by the Web Address shown.

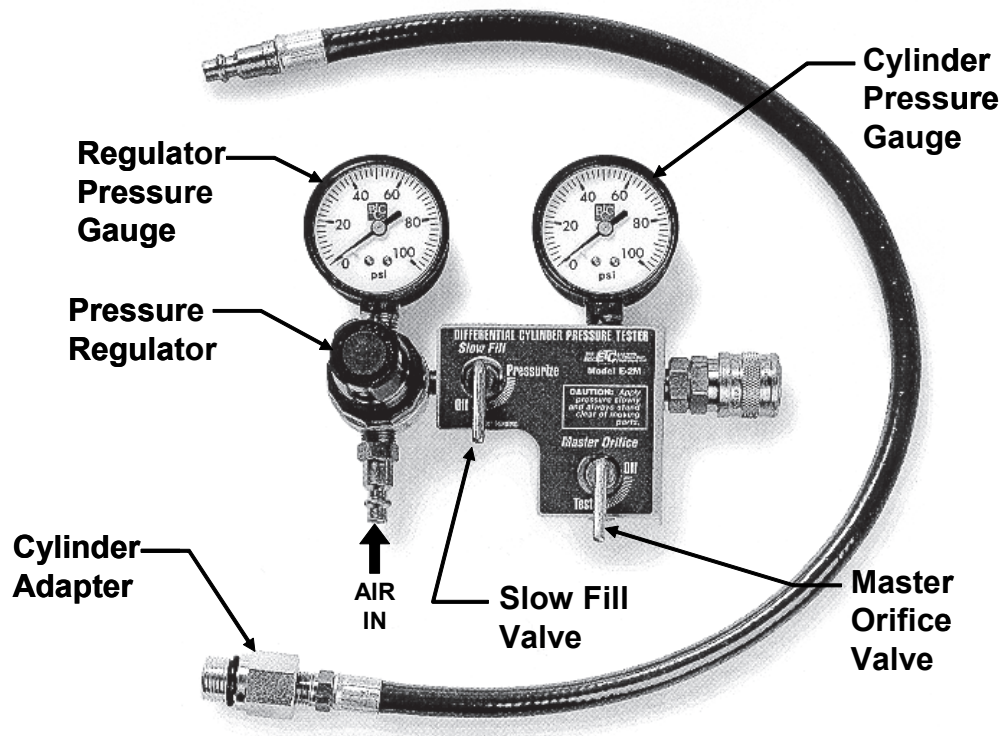

Figure 2-1. Model E2M Differential Pressure Tester (built in Master Orifice Tool)



Figure 2-2. Borescope (Autoscope®)

NOTE: Borescopes are available from multiple manufacturers, with varying levels of features and resolution. The Autoscope® is only one of the available products.

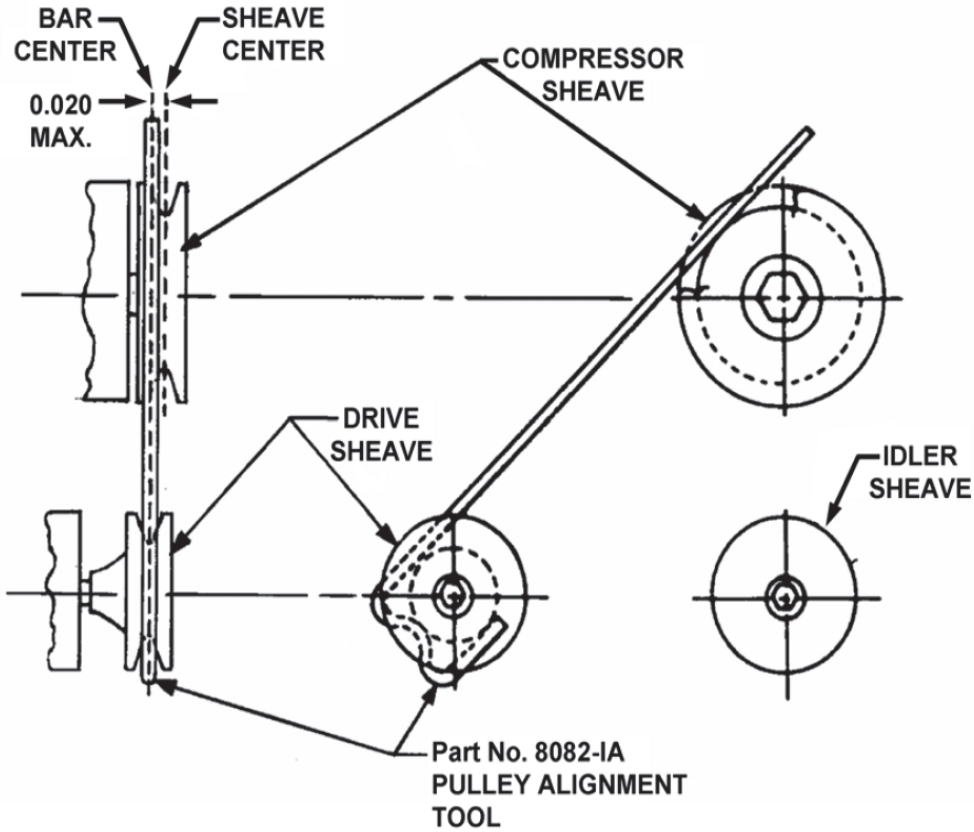

Figure 2-3. Pulley Alignment Tool

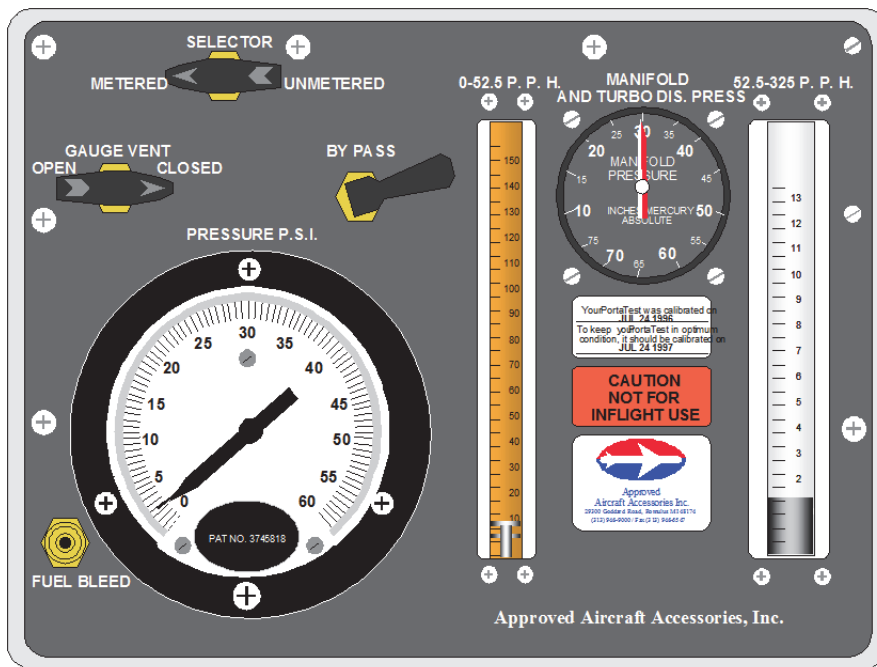

Figure 2-4. Model 20 ATM-C Porta-Test

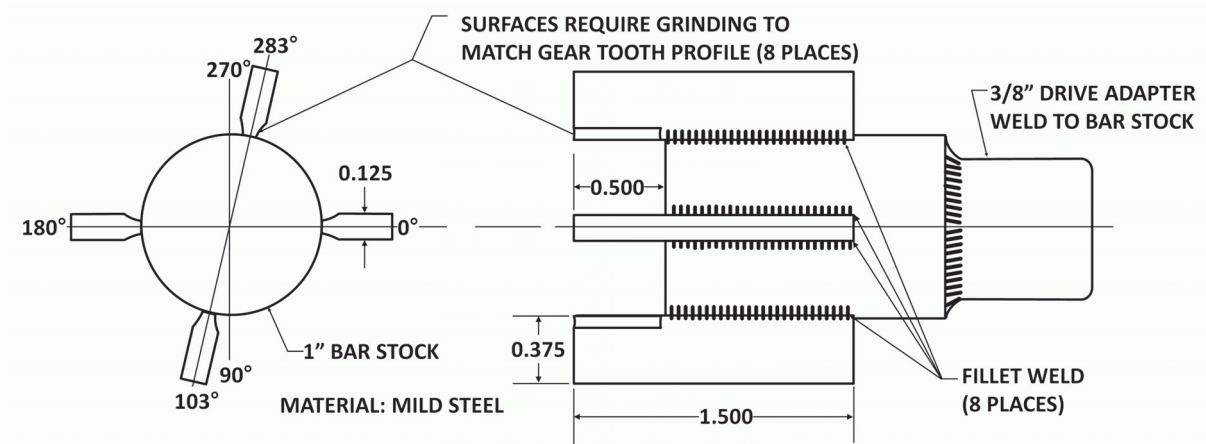

Figure 2-6. Alternator Drive Hub Torque Tool
Used on 200/300/240/360 Series Engines

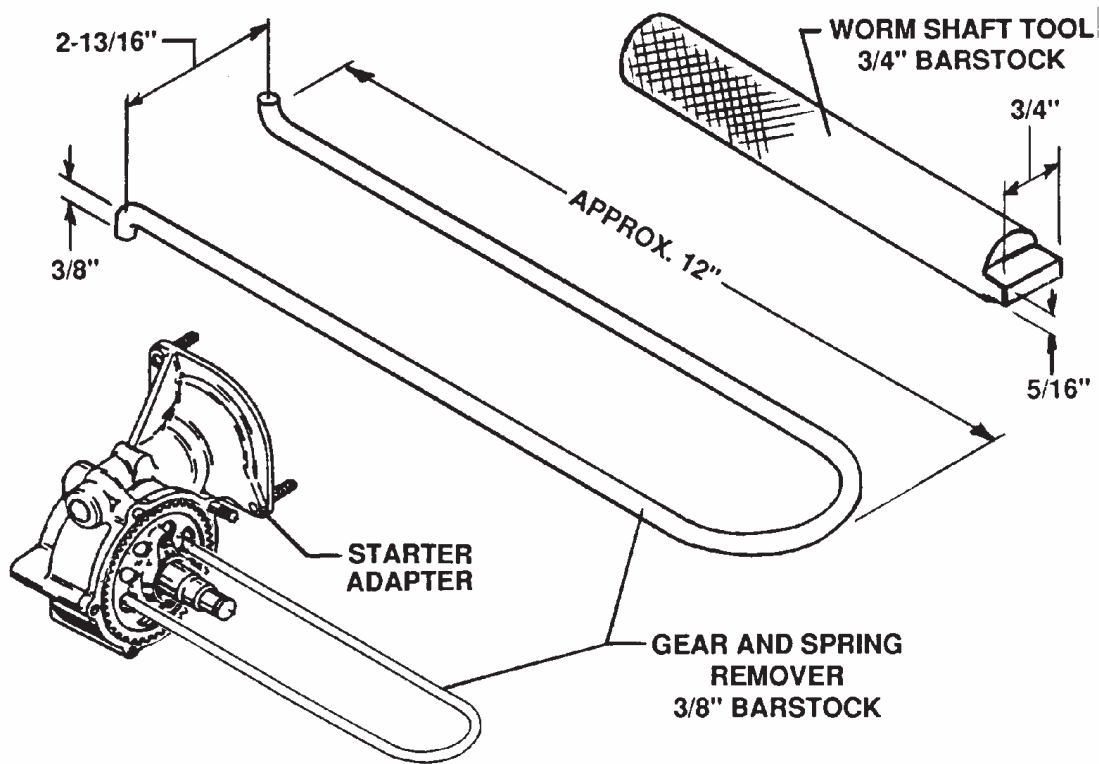

Figure 2-7. Worm Shaft Tool and Starter Adapter Disassembly Tool



NOTE: The Driver for the Oil Control Plug Installation Tool (Figure 2-8 through Figure 2-11) is the same for all installation tools/engine models.

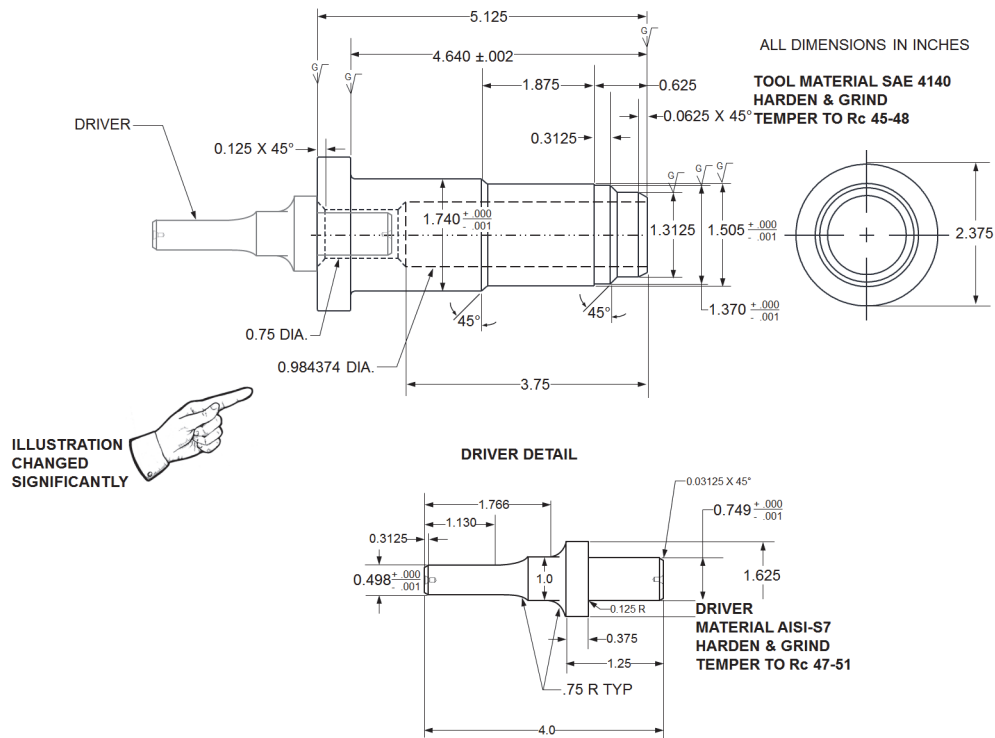

Figure 2-8. Oil Control Plug Installation Tool - 360 Engines

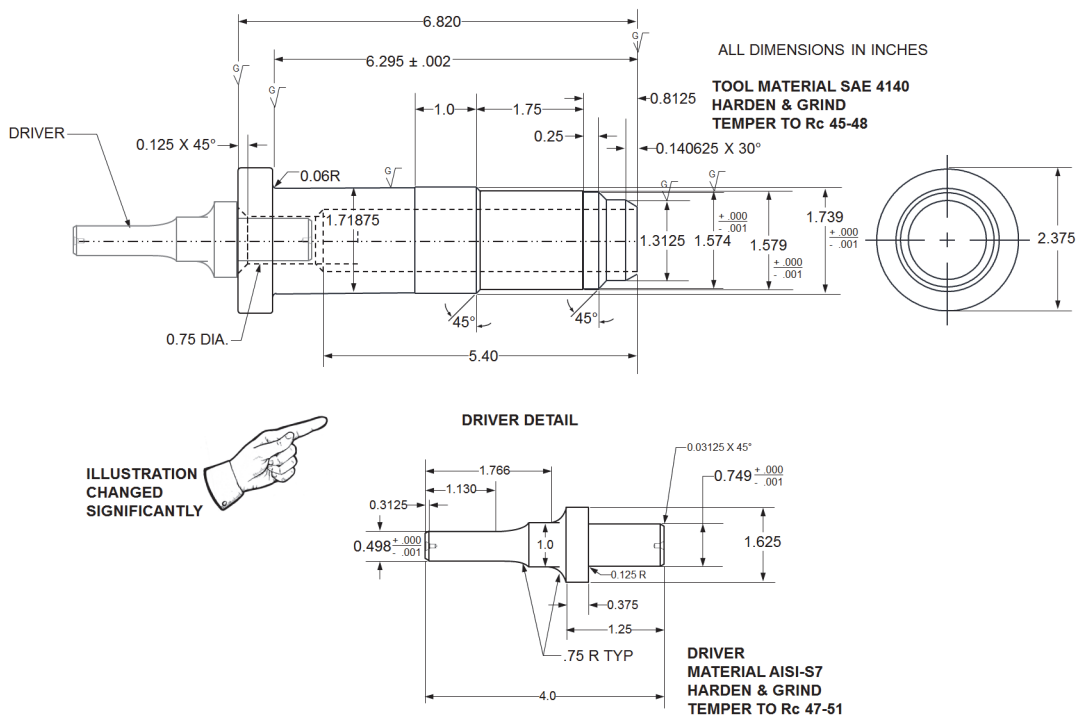

Figure 2-9. Oil Control Plug Installation Tool - 470 Engines

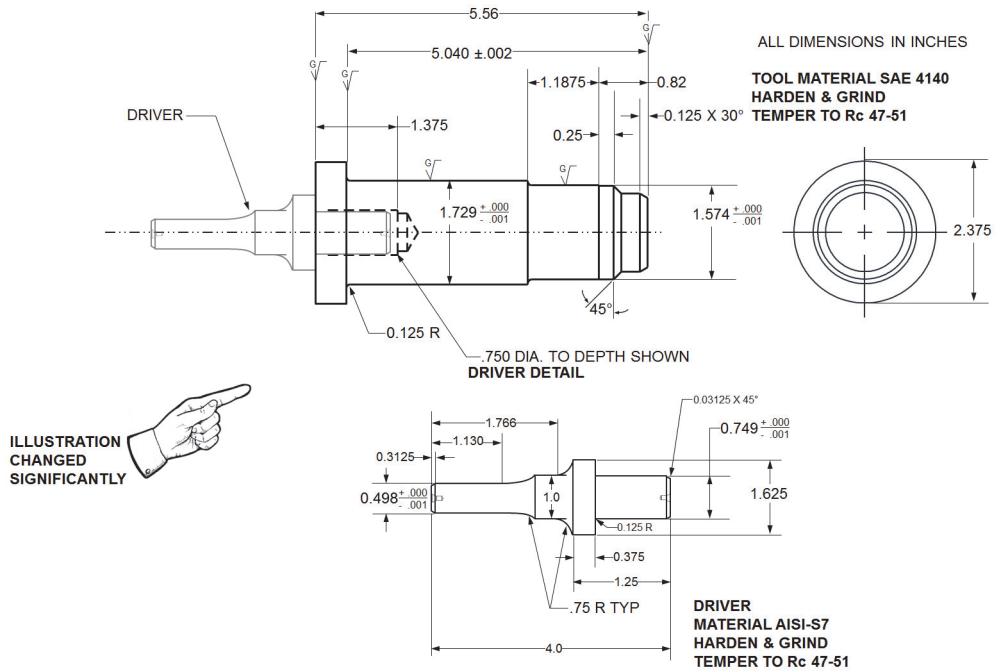

Figure 2-10. Oil Control Plug Installation Tool - 520/550 Permold Engines

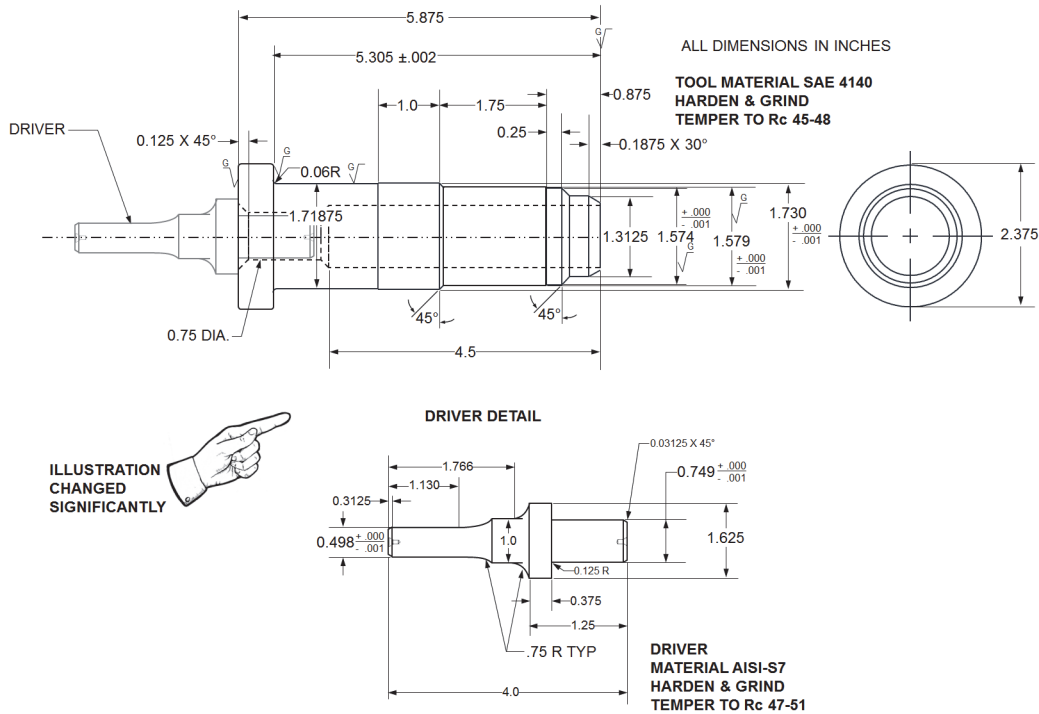

Figure 2-11. Oil Control Plug Installation Tool - 470/520/550 Sandcast Engines

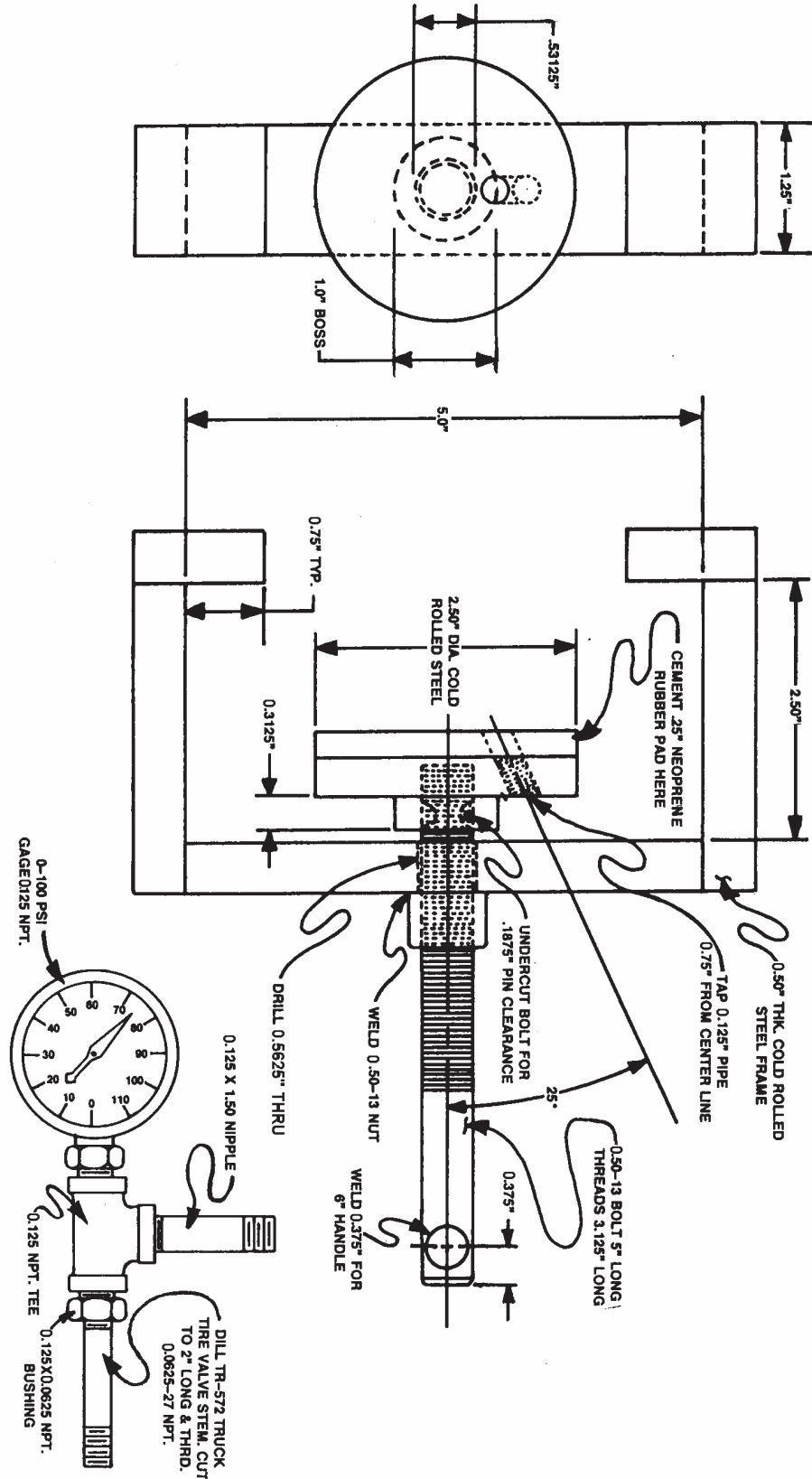

Figure 2-12. Oil Control Plug Leak Test Fixture

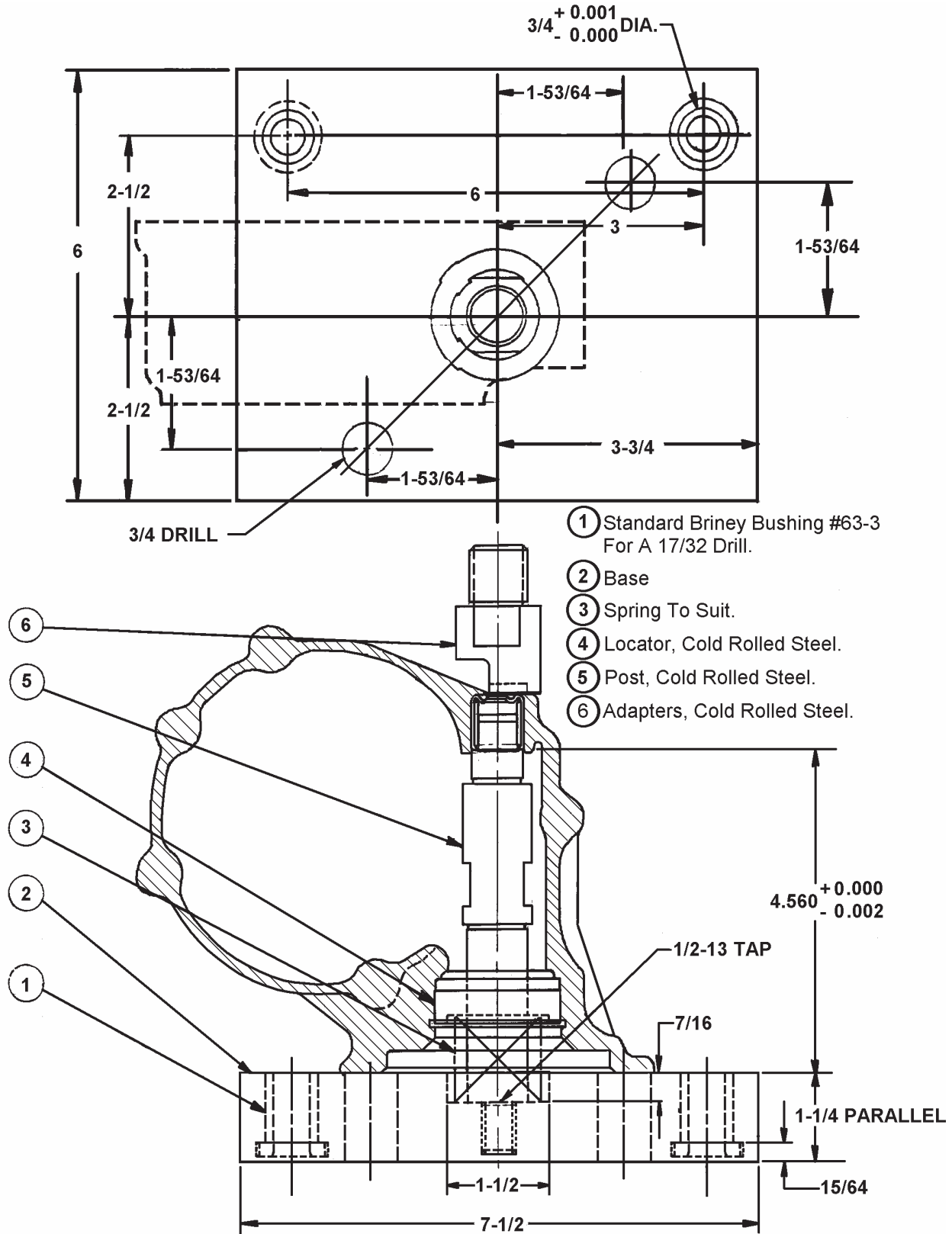

Figure 2-13. Needle Bearing Installation Tool - Part 1

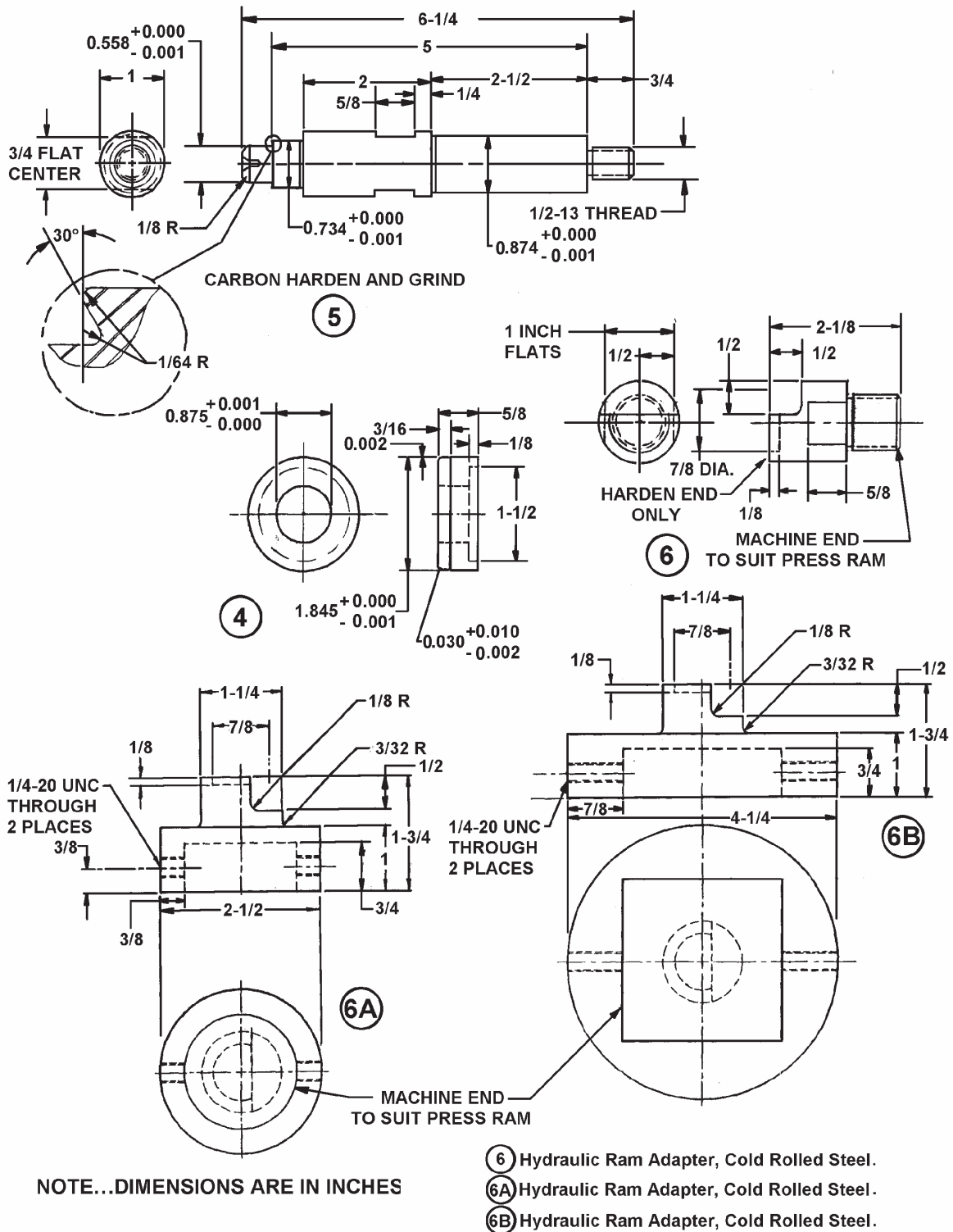

Figure 2-14. Needle Bearing Installation Tool - Part 2

A= 1/64" (0.4mm) Less Than Housing Bore
 B= 0.003 (0.08mm) Less Than Shaft Diameter
 C= Pilot Length Should Be Length of Bearing Less 1/32" (0.8mm)

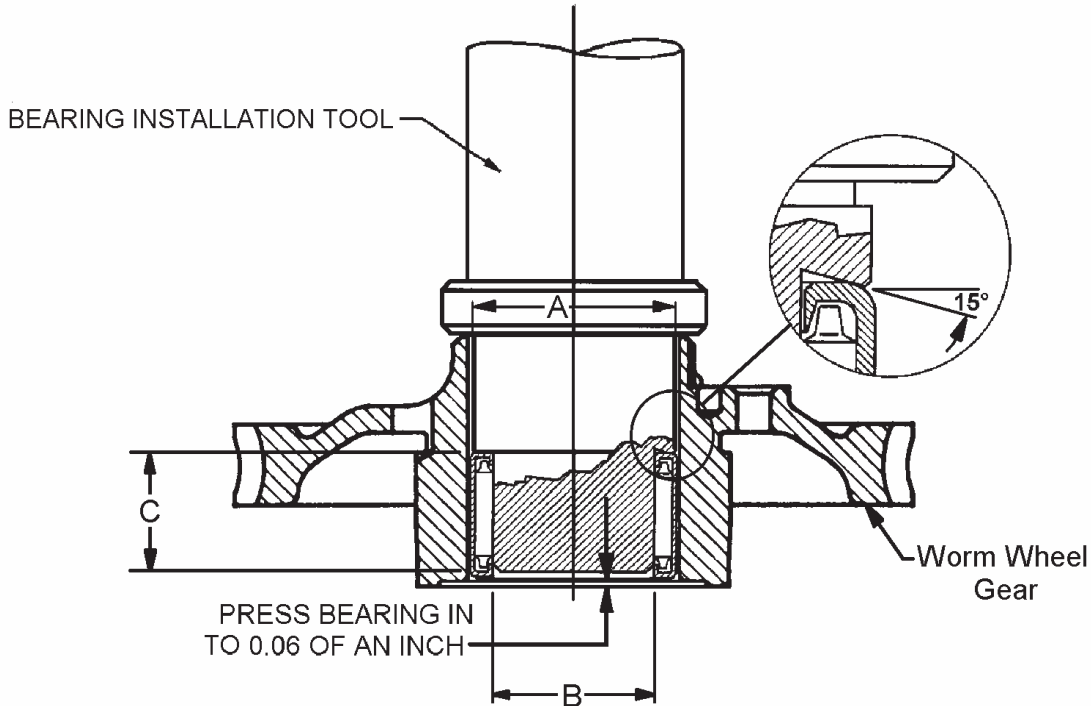

Figure 2-15. Bearing Installation Tool

NOTE: Crankcase Needle Bearing installation tools vary by the depth the needle bearing is installed. For Permold crankcases, the installed depth is 9/16"; for Sandcast crankcases, the needle bearing is installed to 1/2".

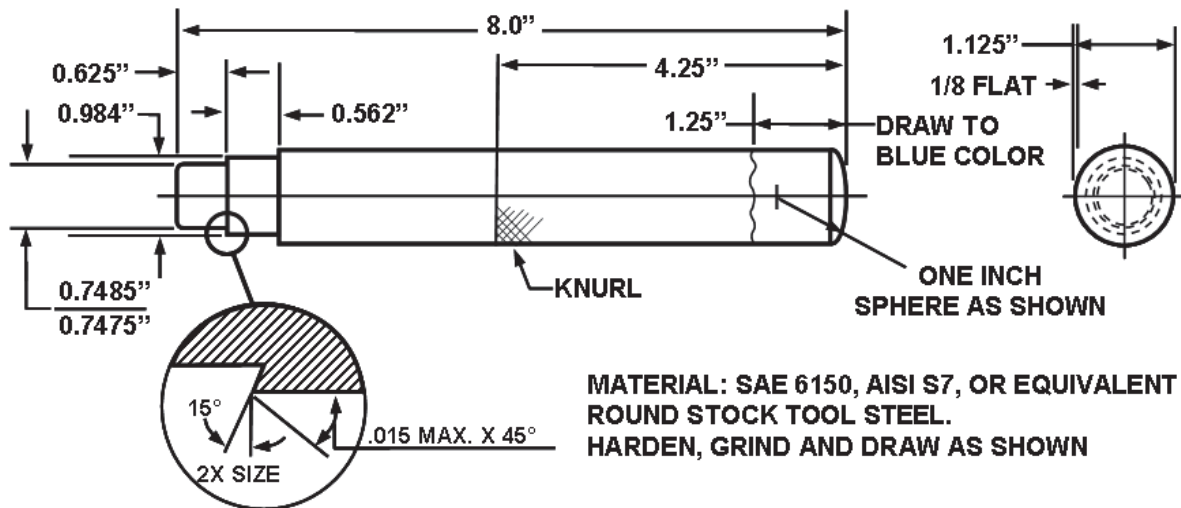

Figure 2-16. Permold Crankcase Needle Bearing Installation Tool

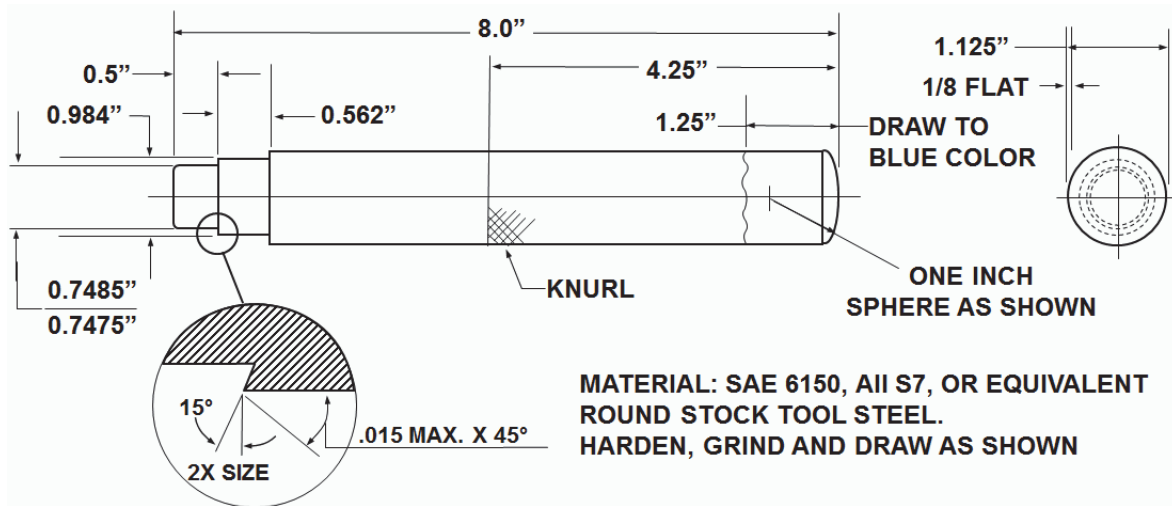

Figure 2-17. Sandcast Crankcase Needle Bearing Installation Tool

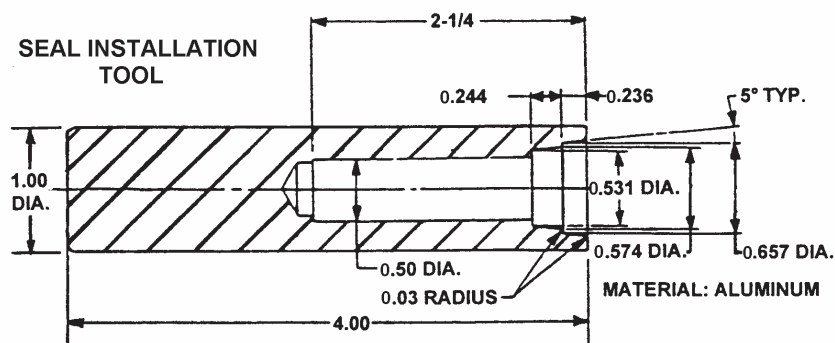
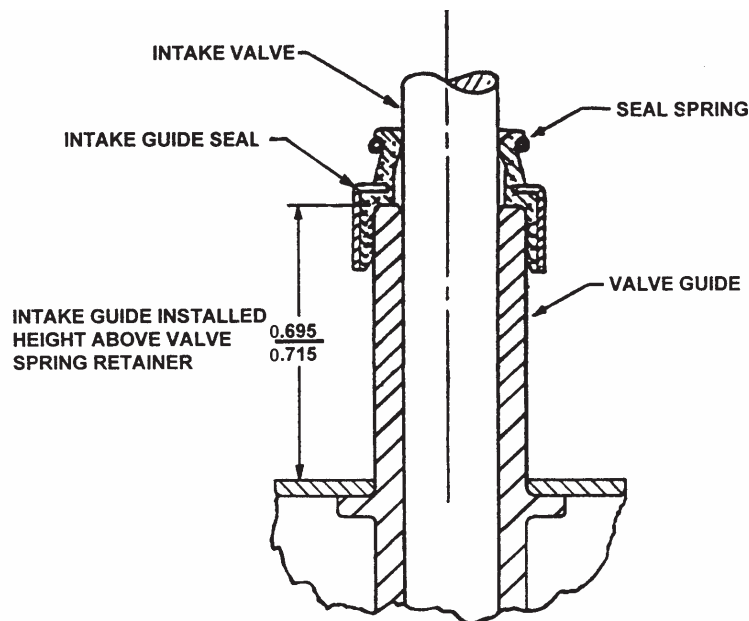

Figure 2-18. Valve Guide Seal Installation Tool

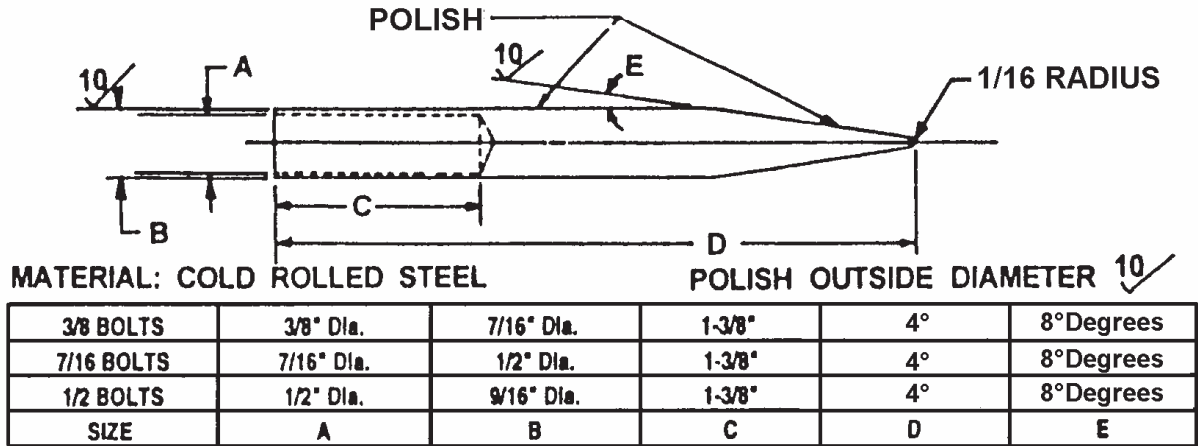

Figure 2-19. O-Ring Installation Tool

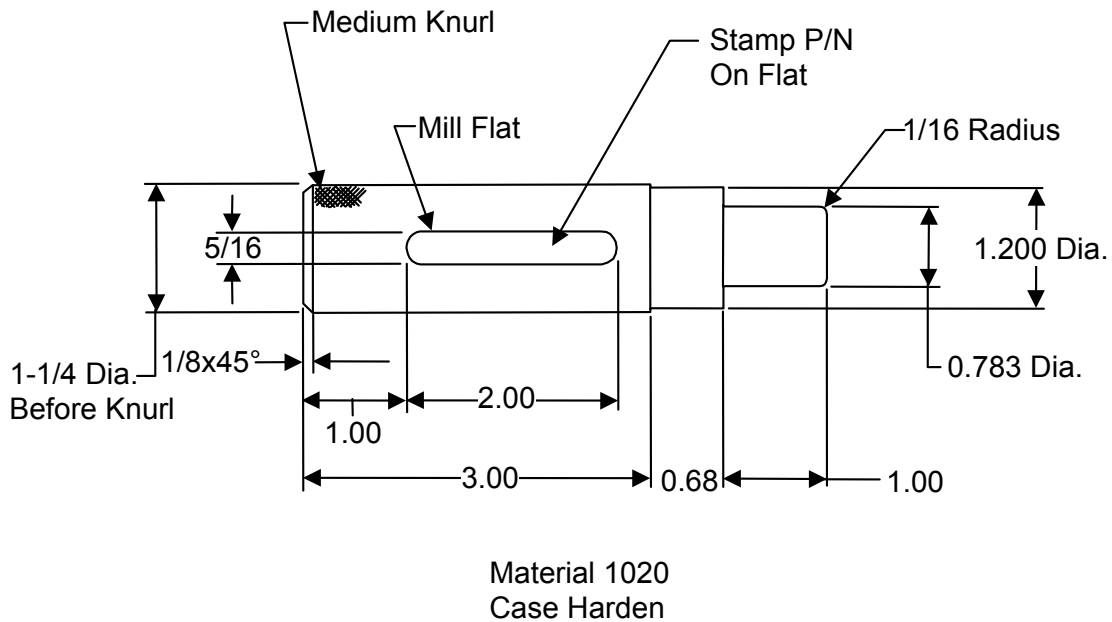

Figure 2-20. Oil Seal Tool

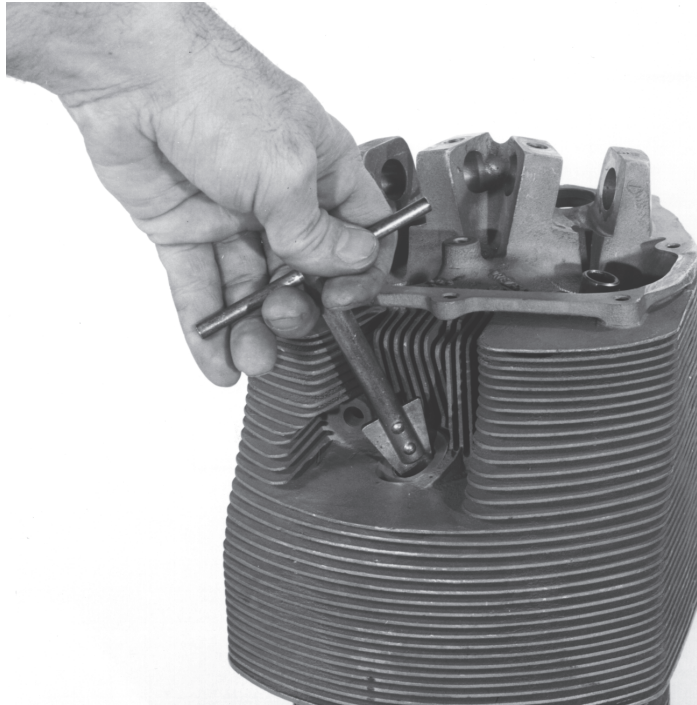

Figure 2-21. Helical Coil Extraction Tool



Figure 2-22. Helical Coil Insertion Tool

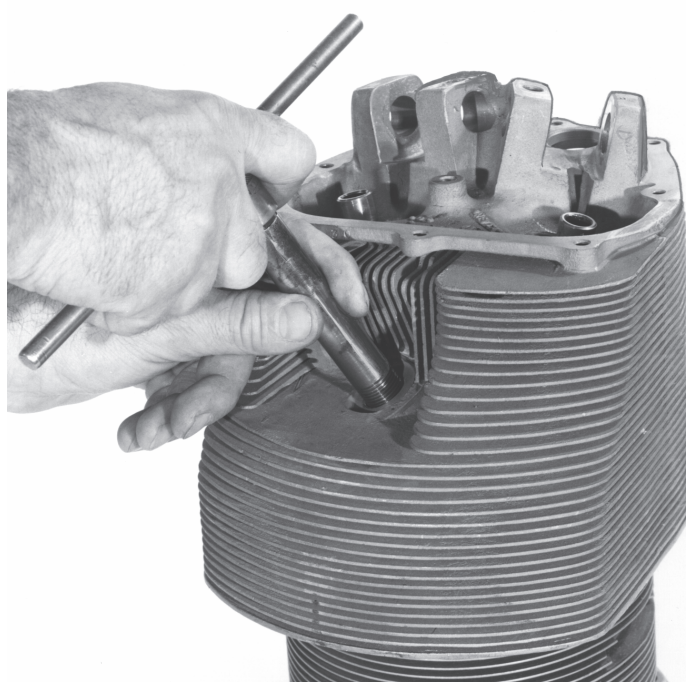

Figure 2-23. Helical Coil Expanding Tool



Figure 2-24. Rosan® Stud Removal Tool



2-2. Mechanic's Tools

The tools listed below are required to perform overhaul procedures on the engines.

Table 2-3. Common Tools

Open end wrenches – 1/4 inch through 1 inch	1/4-inch Slide hammer
Socket wrenches: 1/4-inch drive Socket sizes: 5/32 through 1/2-inch 3/8-inch or 1/2-inch drive Socket sizes: 7/16-inch through 1-1/2-inch	Ratchets: • 1/4-inch drive • 3/8-inch drive • 1/2-inch drive
Deep well sockets: 1/2-inch drive Socket sizes: 7/16-inch drive through 1-inch	Heat Gun (variable intensity/ equipped with a small tip)
Calibrated Torque Wrenches: • 0 to 1000 in-lbs • 0 to 500 in-lbs • 0 to 100 ft-lbs	• Drill, 0.266 (H) Pneumatic drill • 00.339 Drill High speed borer • Drill Index
Micrometers	Ball Peen Hammer
Allen Wrenches - assortment	Pullers
Slotted Screwdrivers – assortment	Blind Bearing Remover
Phillips Screwdrivers – Nos. 1 and 2	Vernier Calipers
Safety Wire Pliers	Leather or soft plastic Mallet
Common Pliers	Small hole gauges, thickness gauges
Diagonal Cutter Pliers	Feeler Gauges (leaf-type)
Needle-Nose Pliers	C-clamps
Duck Bill Pliers	Brass Wire Brush
Snap Ring Pliers (with 90-degree bend)	Stiff-bristled, non-wire Scrub Brush
Inspection light/flashlight	Dry Blaster cleaning tool
Two inch (2") Merrit Wheel (flap wheel)	Air impact tool
T-handle Drive	Toolmaker's Square
Magnifying Glass (10X power)	Profilometer
Mirror	Chamfer Tool
Utility knife	Morse Adapter
Scissors	Heavy Duty Drill Press
Crimp Tool	Arbor Press (and 8-inch arbors)
Wire ties	Vertical Mill
Ring Expander	Engine Hoist
Bench Vise with shielded jaws	Engine Stand
Fiber Drift, Brass Drift, Pin or Punch	Transport dolly
Magnet	Aircraft tie downs and stop blocks
Stud Extractor Tool	V-blocks
Ezy Out	Catch Basins (fuel and oil)
Wood or plastic Spatula	Permanent Marker
Tank Sprayer	Strap Wrench



Intentionally Left Blank



Chapter 3. Lubricants, Sealants, and Adhesives

3-1. Engine Oil Specifications

Lubricating oils qualified for use in Continental Motors aviation gasoline (AvGas) engines are required to meet Society of Automotive Engineers (SAE) specifications. SAE J1899 is the specification for aircraft piston engine ashless-dispersant oil. SAE J1966 is the specification for aircraft piston engine non-dispersant mineral oil.

Lubricating oil meeting these specifications is acceptable; proof of conformity is the responsibility of the lubricant manufacturer.

Lubricating oil classified by North Atlantic Treaty Organization (NATO) or Standardization Agreement (STANAG) as interchangeable with oils qualified under SAE J1899 or SAE J1966 and assigned NATO codes O-123 or O-128 shall be considered qualified.

The marketers listed in Table 3-1 have supplied data to Continental Motors indicating the products conform to one or more of the requirements above

Continental Motors recommended oil grades:

- Above 40°F ambient air, sea level SAE 50 or multi-viscosity
- Below 40°F ambient air, sea level SAE 30 or multi-viscosity



Table 3-1. Qualified SAE J1899 Ashless Dispersant Engine Oil

Supplier	Brand
Air BP Lubricants	Castrol Aviator AD Oil
	Castrol Aviator A Oil
ChevronTexaco	ChevronTexaco Aero Oil AD
	ChevronTexaco Aero Oil AD SAE 20W-50
Delta Petroleum Company	Delta Avoil Oil
ExxonMobil Aviation	Exxon Elite
Gulf Oil Company	Gulfpride Aviation AD
NYCO S.A.	Turbonycoil 3570
Pennzoil Company	Pennzoil® Aircraft Engine Oil
Phillips 66 Aviation ConocoPhillips	Phillips 66 Type A 100 AD, 120 AD
	Phillips 66 Victory Aviation Oil 100AW
	Phillips 66 X/C Aviation Oil SAE 20W-50, SAE 25W-60
Quaker State Oil & Refining Co.	Quaker State AD Aviation Oil
Red Ram Limited (Canada)	Red Ram X/C Aviation Oil 20W-50
Shell Aviation	Aeroshell Oil, (Mineral) 65, 80, 100, 2F Anti Corrosion Formula
	Aeroshell Multi-grade Oil AD, 15W - 50
	Aeroshell Oil W65, W80, W100
	Aeroshell Oil W80 Plus, W100 Plus Anti Corrosion Formula
Sinclair Oil Company	Sinclair Avoil
Total Lubricants	Total Aero DM 15W - 50
	Total Aero 80 (SAE 40), 100 (SAE 50)
	Total Aero XPD 80 (SAE 40), XPD 100 (SAE 50)

Table 3-2. Break-in Oil

Type	Equivalent	Application
SAE J1966 Aviation	Non-dispersant mineral oil for piston aircraft engines	First 25 hours of engine operation or until oil consumption stabilizes
MIL-C-6529 Type II Corrosion preventive mineral oil	Fly-away oil	

NOTE: Mineral oil conforming to MIL-C-6529 Type II contains a corrosion preventive additive and must not be used for more than 25 hours or six months, whichever occurs first. If oil consumption has not stabilized in this time, drain the mineral oil, replace the oil filter and replace the discarded mineral oil with SAE J1966 aviation oil.

Table 3-3. Preservative Oil

Type	Equivalent	Application
MIL-P46002	Grade 1 Oil, Non-Rust VCI-105	Temporary or Indefinite Storage. Sprayed in cylinders (Section 9)
	Motorstor Engine Protectant	



3-2. Oil Change Intervals

Refer to the engine maintenance manual and/or the aircraft manufacturers or Supplemental Type Certificate (STC) holders AFM/POH for oil specifications, specified oil change intervals and inspection procedures.

Oil change intervals published in this manual are minimum requirements. Continental Motors believes more frequent oil and filter changes enhance engine service life. Drain and replenish engine oil every 25 hours of operation or 4 months for engines that incorporate a reusable oil screen. On engines with the full flow oil filters, large or small replaceable oil filter cartridge, change the oil and filter every 50 hours and/or 4 months. Inspect oil screens and oil filter elements for contaminants at each oil change. Oil analysis may be used in addition to the oil screen or filter element inspection, but not as a replacement for it.

3-3. Additives

We often receive inquiries regarding the potential use of alternative fuel and oil additives and/or concentrates (formulated primarily for automotive and industrial engine applications) for use in our aircraft engines. Most of these additives and concentrates are not compatible with air-cooled, light aircraft engines in their operating environments. With the exception of the use of isopropyl alcohol or diethylene glycol monomethyl ether (DiEGME) compound (described in the following paragraph), we do not recommend the use of additives or concentrates in any of our aircraft engines. The use of unapproved additives may void the engine warranty. Use only recommended fuels and lubricants.

WARNING

Mixing of the DiEGME compound with fuel concentration in excess of the recommended (0.15 percent volume maximum) could have a harmful effect on engine components. Use only the manufacturer's recommended blending equipment and procedures to achieve proper proportioning.

Under certain ambient conditions of temperature and humidity, sufficient quantities of water may exist in the fuel to create restrictive ice formation in the fuel supply. To alleviate this occurrence, it is permitted to add no more than three percent Isopropyl Alcohol to the fuel supply. Also, DiEGME conforming to military specification MIL-DTL-85470B, if approved by the aircraft manufacturer, may be added for this purpose. DiEGME compound must be carefully mixed with the fuel in concentrations not to exceed 0.15% (by volume).



Table 3-4. Sealants

CM Part Number	Type	Application	Remarks
642188	CRC Copper Coat 401504 Gasket Sealant	Non-beaded gaskets; Apply both sides of starter gasket, oil cooler adapter gasket, vacuum pump adapter gasket, and fuel pump pad cover gasket. Beaded gasket; Apply to non-beaded side of starter gasket, oil cooler adapter gasket, vacuum pump adapter gasket, and fuel pump pad cover gasket.	0200D, X
		All press type plugs (Hubbard etc.)	All models
		Intake manifold gasket	
		ACC case to crankcase (crankcase side only)	C-90, O200, IO240, O300, IO360, LTSIO360, TSIO360
		Oil drain back tubes	C-90, O200, O300
		Oil cooler (both sides)	IO360, LTSIO360, TSIO360
		Oil seal accessory drive (O.D. only)	IO360, LTSIO360, TSIO360
		2 bolt suction tube gasket (both sides)	470, 520 and 550 (where applicable)
		Gasket and oil filler neck holes	470, 520, 550 (Sandcast), and GTSIO520
		Cam bore cover gasket (except beaded gasket)	470, 520, 550, GTSIO520, IO240
		Idler pin gasket	470, 520, 550, GTSIO520
		In parting line area of 3-way joints	Sump to crankcase or sump to crankcase to accessory case
		All gaskets (both sides) except magneto gasket and gaskets between intake manifold and cylinder head.	TIARA 6-285, 6-230
		Oil seal at alternator drive (O.D. only)	
646940	F/I Sealant Loctite 569 Hydraulic Sealant	All pipe thread fittings in fuel injection system (except pipe plug threads in throttle body units)	See Figure 3-2
646942	Gasket Maker Loctite 515 Gasket Eliminator Flange Sealant	Crankcase parting face	Where applicable
		Engine nose seal, scavenge oil pump covers, between crankcase and sump gasket, oil pump covers	All models, where applicable
		Between starter adapter gasket & crankcase	All Permold crankcase models
		Between oil sump and sump gasket	Non-beaded gaskets only
		642910 oil seal, O.D. of all uncoated oil seals, except fuel pump adapter seal	All models, where applicable
649246	Loctite 290 Sealant	Data plate screw installation on throttle bodies	All models, where applicable
653692	Loctite LocQuic Primer 7649	Crankshaft nose oil seal area	All models



Table 3-4. Sealants

CM Part Number	Type	Application	Remarks
654663	Loctite 30516 Gasket Sealant (with P/N 641543 Silk Thread)	Crankcase parting face	Apply according to assembly instructions
		Starter adapter to accessory case	
		Accessory drive adapter	
		Pressure oil pump covers Pressure scavenge pump covers	
657042	Loctite 565 Adhesive Sealant	Use on all pipe threads to oil coolers and other oil sources	All models (use sparingly on male threads only)
N/A	Miller-Stephenson MS-122AD	Ignition harness terminals at magneto block end & spark plug / ECU terminals	All models
N/A	Loctite 592 Teflon PS/T Pipe Sealant	Use on all pipe threads except as noted elsewhere All pressure relief valve housing threads Permold 2 studs engine mount 1-3-5 side bottom	All models, where applicable
		All threaded fasteners installed in a stud hole through to an oil source	Apply before installing threaded fastener

Table 3-5. Lubricants

CM Part Number	Type	Application	Remarks
646943	Loctite 76732 Anti-Seize Lubricant	Fuel injector nozzles (at cylinder head)	See Figure 3-1
		Mechanical tachometer drive housing threads not connected through to an oil source.	At engine assembly
		Exhaust studs (applied to nut end before torque), exhaust slip joints	All except TS10L550
		Vernatherm plug	At engine assembly
		All 0.3125 and larger studs unless otherwise noted	At engine assembly At engine assembly
		Throttle body air reference fittings	Where applicable
		Oil sump return fitting	IO360ES3B, 14B, & IO360HB9B
654468	Shell #5 MIL-G-3545-C Grease	Fuel injection linkages	At engine assembly
		Throttle & mixture control linkages	Apply at pivot points during assembly and periodic maintenance
654514	CRC 336 Rust Preventative Compound	Spray exhaust end of turbocharger	After engine test
654561	Shell Alvania # 2	Light coat at contact point between nut seat and ignition lead ferrule	All models, where applicable
		Apply to oil seal lip only (alternator seal)	LTSIO360E, EB, RB; TSIO360E, EB, F, FB, GB, KB, LB
		Apply to crankshaft nose oil seal lip	All models



Table 3-5. Lubricants

CM Part Number	Type	Application	Remarks
656817	Super Molyshield Grease	Starter worm gear & bevel gear teeth	All models during engine assembly
		Needle bearings and ball bearings	
		Valve stems	
		Accessory drive splines and couplings	Where applicable
		Idler gear and pin	470, 520, 550
		Magneto rubber drive bushings	All models
		Oil seal lips only	
		Fuel injection controls, o-rings, springs, shafts, and bushings	Except 360, TSIO520D, GTSIO520K, which use 50W motor oil
		Oil pumps (pressure & scavenge)	Coat gear cavity during pump assembly
		Adapter (tach reduction)	TSIO & LTSIO360
N/A	Use only manufacturer's recommended spark plug thread lubricant	Spark plugs	All models
N/A	Chesterton #995 Release Agent or WD-40	Induction system hoses and flex duct connections, pipe plugs in throttle body units	All models
N/A	Dow Corning No. 4	Rubber oil seal of spin-on oil filters	All models where applicable
		Governor pad gaskets (both sides)	
		Starter adapter cover o-rings	
N/A	Dow Corning G-N Paste	Camshaft lobes and tappet faces	During engine assembly
N/A	LPS 2	Throttle and Mixture Control Valves Linkages	Apply at pivot points during maintenance
N/A	Lubriplate 630 AA (optional)	Throttle and Mixture Control Valves Linkages	Apply at pivot points during assembly
N/A	Lubriplate 930 AA	O.D. of valve guides	All models during valve guide installation
N/A	Mouse Milk	Wastegate butterfly and linkage	Carbon solvent used on turbocharged engines during preventive maintenance
N/A	SAE J1966 Grade 50 Aviation Oil	Quill Shaft Springs	GTSIO520
		Crankshaft bearings	During engine assembly
		Connecting rod bearings	
		Prop driver, driven gears & bearings	
		Camshaft bearings	
		Tachometer gears & adapters	
		Accessory spur gear teeth	
		Prop governor transfer collar & sleeve	
		Starter cone, bushing & nut	
Starter clutch spring (ID & OD)			



Table 3-5. Lubricants

CM Part Number	Type	Application	Remarks
N/A	SAE J1966 Grade 50 Aviation Oil (continued)	Pistons, piston pins, & piston rings	
		Thrust washers	
		Oil filter adapter seals	
		O-rings (unless otherwise specified)	
		Carburetor fuel connections	Carburetor-equipped models
		Valve guide seals	Apply to sealing surface
		V.T.C. unit pistons & centrifugal valves, rocker arms, valves and tappets	TIARA 6-285, 6-230
		Cylinder studs, through bolts, crankcase studs, connecting rod bolts and nuts; and engine accessory studs unless installed in blind or stud holes not through to an oil supply or otherwise specified	Lubricate bolt thread and nut seat before tightening nuts
	Cylinder exhaust port flange studs	TSIOL550 ONLY	

Table 3-6. Adhesives

CM Part Number	Type	Application	Remarks
646941	Loctite 271 High Strength Adhesive Sealant (used with P/N 653693 Loctite 7471 Primer)	Cylinder deck studs	Breakaway torque minimum 100 in-lbs. after two hours
		Crankcase breather tubes	470 & 520 (Sandcast) & GTSIO520
		Crankcase nose seal retainer bolts	All models
		Intake manifold mount studs	C-75, C-85, C-90 & O-200
		Mechanical tachometer drive studs trough to an oil source	where applicable
		Oil gauge rod housing to crankcase	IO360, LTSIO360, TSIO360, O470, IO470, TSIO470, IO520A, B, E, G, J, K, L, IO550D, E, F, TSIO520A, AE, AF, C, CE, G, H, M, P, R, T
		Oil pump gear mounting pin in accessory cover	IO360, LTSIO360, TSIO360
		Press fit breather and oil fill necks	IO240, IO360, LTSIO360, TSIO360
		Rocker cover studs, rocker arm pivot studs, push rod retainer stud	TIARA 6-285, 6-230
		Timing indicator pin	GTSIO-520
		Top accessory drive gear (breather slinger) bolts	TIARA 6-285, 6-230
		V.T.C. unit bushing retainer screws	
V.T.C. unit housing to crankshaft			



Table 3-6. Adhesives

CM Part Number	Type	Application	Remarks
649306 (optional 646940)	Loctite 222 Sealant (or optional Loctite Hydraulic Sealant 569)	Solenoid Valve assembly (bracket to valve)	Engines with priming system solenoid valves, as applicable
		Manifold valve to bracket screws	All models
		Coolant pump impeller ring screws	All liquid cooled models
		Studs 0.25 diameter and smaller <i>(do not use on cylinder exhaust port flange)</i>	All models
		Mag stud holes and stud holes through an oil source on accessory end of crankcase	0200, IO240, 0300, IO360, LTSIO360, TSIO360, 470, 520, 550 (apply when installing studs)
		All pipe thread fittings in fuel injection system except pipe plug threads in throttle body unit	All models
649366	Loctite 242	Magneto housing pressurization fitting	All models, where applicable
652983	Loctite 620 Adhesive Sealant	Coolant pump mechanical seal, standard repair on starter adapter bearing bore	All liquid cooled models
654495	Loctite 8531 Adhesive Sealant	Starter clutch assembly bearing	O200, O300, IO240, 0470, IO470, IO520, L/TSIO520, IO550, TSIOL550
654562	Loctite 609 Adhesive / Sealant	Bearing OD installed on starter clutch assembly	O200A, B, IO240A, B, O300A
655515	Adhesive Sealant (RTV)	Alternator assembly	GIO550, GTSIO520, IO520, IO550, IOF550, TSIOL550, TSIOF550
655700	PBC30 Adhesive	Induction Manifold (Felt to Manifold)	I0360AF, ES; TSI0360MB, RB, SB; LTSI0360RB; IO550G, N, P, R; IOF550; TSI0520BE; TSI0550; TSIOF550D, J, K, P;
		Cylinder Baffle (Grommet to Baffle 658503)	IO550G, N, P, R; IOF550N, P, R; TSI0520BE; TSI0550; TSIOF550;
		Baffle Assembly-Oil Cooler (Seal to Baffle 658064)	TSI0550K, N
658493	3M Scotch-Weld 1300 Adhesive	Bracket-Injection Lines (Bumper To Bracket 658514)	IO550R
		Diverter Valve Bracket (Bumper To Bracket 656225)	IOF550B, C, D, E, F, L
800126	3M Super 77 Adhesive	EMI Gasket	All FADEC (apply to gasket before installing on ECU)
		Cylinder Baffle (Rubber Isolator To Cylinder Baffle 657488)	0200D



Table 3-7. Miscellaneous

P/N	Type	Application	Remarks
535011	Safety wire -.032 in dia. Steel Corrosion Resistant	Where safety wire is required	N/A
800154	Safety wire -.020 in dia. Steel Corrosion Resistant	Where safety wire is required	FADEC electronic control units
626531-1	Enamel - Gold (1 qt)	High temperature paint for cosmetic and corrosion protection	N/A
626531-2	Enamel - Gold (1 gal)		
N/A	"ACCELAGOLD" Turco Products	Corrosion protection interior and exterior aluminum parts	N/A
658555-1	Primer, Zinc Phosphate (Armor Tech Epoxy Ester Primer)	Cylinders (through hardened cylinder barrel touch-up only)	All Models (w/through hardened cylinder barrels)



3-3.1. General Sealant Application Instructions

CAUTION: Never use Teflon tape on fluid fittings or fuel nozzles. Only apply sealants or lubricants to fitting tapered ends up to the first two threads. Never apply to the first two threads to prevent contaminating fuel supply.

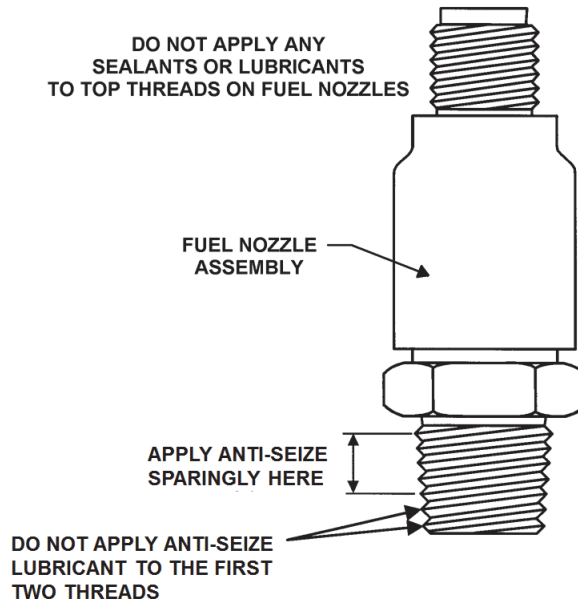

Figure 3-1. Anti-Seize Lubricant Application

CAUTION: Apply Part Number 646940 F/I Sealant to the tapered threads of the fitting only. Never use Teflon tape on fluid fittings of fuel injector nozzles.

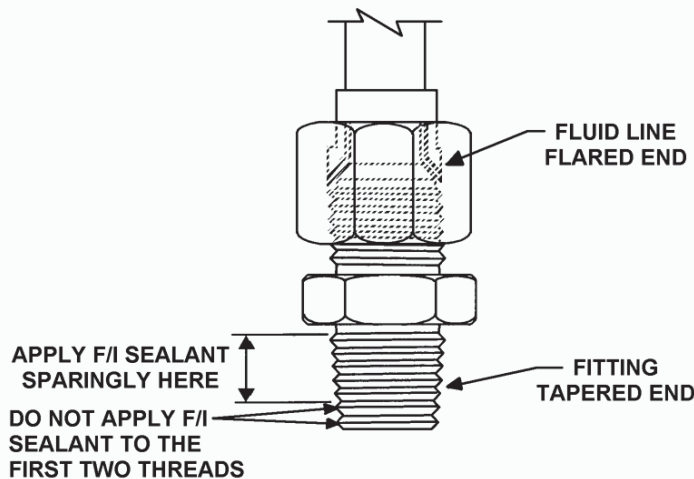

Figure 3-2. Fuel Injection Sealant Application



3-3.1.1. Four Cylinder Engine Crankcase Threading

WARNING

Do not apply any form of sealant to the crankcase cylinder deck, chamfer, cylinder mounting flange, cylinder base O-ring, or cylinder fastener threads. The use of RTV, silicone, Gasket Maker or any other sealant on the areas listed above during engine assembly will cause a loss of cylinder deck stud or through-bolt torque. Subsequent loss of cylinder attachment load, loss of main bearing crush and/or fretting of the crankcase parting surfaces will occur. The result will be cylinder separation, main bearing movement, oil starvation and catastrophic engine failure. USE ONLY CLEAN 50 WEIGHT AVIATION ENGINE OIL ON SURFACES LISTED.

1. Use full strength, non-thinned P/N 654663 (gasket sealant). Shake or mix well before using.

CAUTION: Apply gasket sealant and threading (a continuous, single piece) only as illustrated. Do not apply gasket sealant to crankshaft nose seal area.

2. Apply P/N 654663 (gasket sealant) to 2-4 case half according to the manufacturer's instructions only in areas where threading is indicated. When applying, use short light brush strokes until an even thin coat is obtained. The gasket sealant should be viscous enough that most of the brush marks disappear; if not, discard the old gasket sealant and reapply with new gasket sealant.

NOTE: Allow the gasket sealant to air dry to a tacky condition before applying silk threading.

3. Apply a thin translucent coat of P/N 646942 (gasket maker), not to exceed 0.010 inch thick, to the 1-3 case half. Apply gasket maker in all areas that will mate against areas where gasket sealant was applied on the matching 2-4 case half (except the through bolt bosses).
4. Apply and position P/N 641543 (a continuous, single piece of grade "D" silk thread) on the 2-4 case half as specified (see Figure 3-3 or Figure 3-4). Ensure the free ends of the thread will be covered by gasket material (except at the nose oil seal).
5. Assemble crankcase halves; install and torque all crankcase hardware in proper sequence in accordance with the applicable overhaul manual as soon as possible.

NOTE: Take care to prevent displacement or damage to the crankshaft oil seal and silk thread. Ensure thrust washer halves and bearing halves remain in place.

6. After crankcase torque, follow the instructions in Section 10-10 to install the nose oil seal.

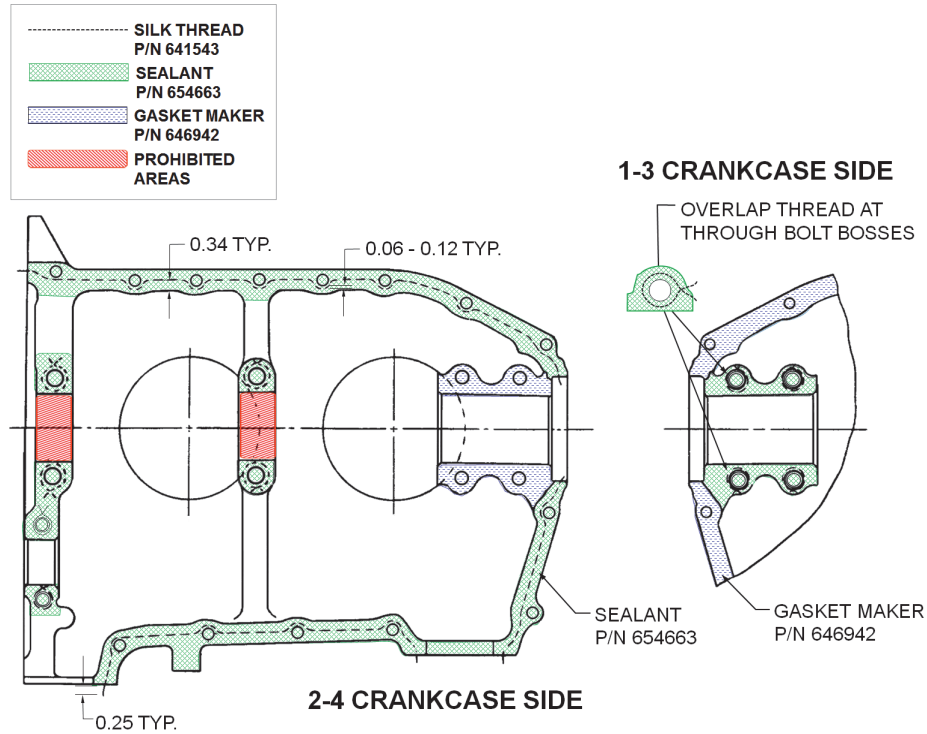

Figure 3-3. Crankcase Threading Diagram - C75, C85, C90, O200

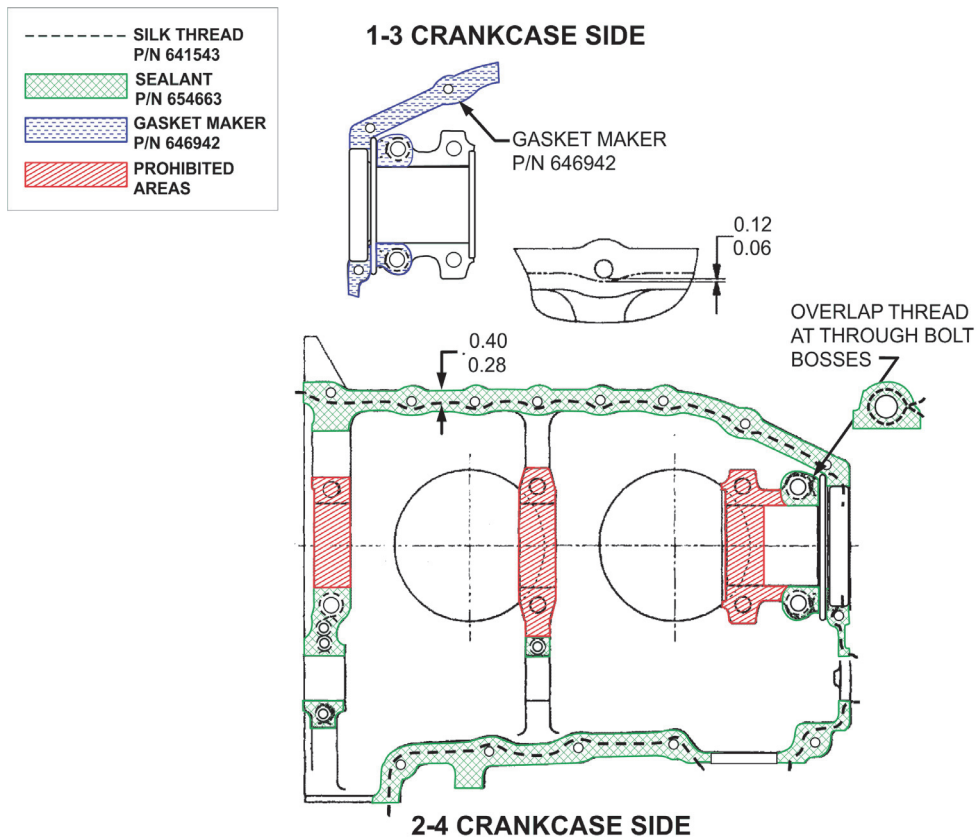

Figure 3-4. Crankcase Threading Diagram - O240, IO240, IOF240



3-3.1.2. Six Cylinder Engine Crankcase Threading

WARNING

Do not apply any form of sealant to the crankcase cylinder deck, chamfer, cylinder mounting flange, cylinder base O-ring, or cylinder fastener threads. The use of RTV, silicone, Gasket Maker or any other sealant on the areas listed above during engine assembly will cause a loss of cylinder deck stud or through-bolt torque. Subsequent loss of cylinder attachment load, loss of main bearing crush and/or fretting of the crankcase parting surfaces will occur. The result will be cylinder separation, main bearing movement, oil starvation and catastrophic engine failure. USE ONLY CLEAN 50 WEIGHT AVIATION ENGINE OIL ON SURFACES LISTED.

1. Use full strength, non-thinned P/N 654663 (gasket sealant). Shake or mix well before using.

CAUTION: Apply gasket sealant and threading (a continuous, single piece) only as illustrated.

2. Apply P/N 654663 (gasket sealant) to 2-4-6 case half according to the manufacturer's instructions only in areas where threading is indicated. When applying, use short light brush strokes until an even thin coat is obtained. The gasket sealant should be viscous enough that most of the brush marks disappear; if not, discard the old gasket sealant and reapply with new gasket sealant.

NOTE: Allow the gasket sealant to air dry to a tacky condition before applying silk threading.

3. Apply a thin translucent coat of P/N 646942 (gasket maker), not to exceed 0.010 inch thick, to the 1-3-5 case half. Apply gasket maker in all areas that will mate against areas where gasket sealant was applied on the matching 2-4-6 case half (except the through bolt bosses).
4. Apply and position P/N 641543 (a continuous, single piece of grade "D" silk thread) on the 2-4-6 case half as specified (see Figure 3-6 through Figure 3-9). Ensure the free ends of the thread will be covered by gasket material (except at the nose oil seal).
5. Assemble crankcase halves; install and torque all crankcase hardware in proper sequence in accordance with the applicable overhaul manual as soon as possible.

NOTE: Take care to prevent displacement or damage to the crankshaft oil seal and silk thread. Ensure thrust washer halves and bearing halves remain in place.

6. After crankcase torque, follow the instructions in Section 10-10 to install the nose oil seal.

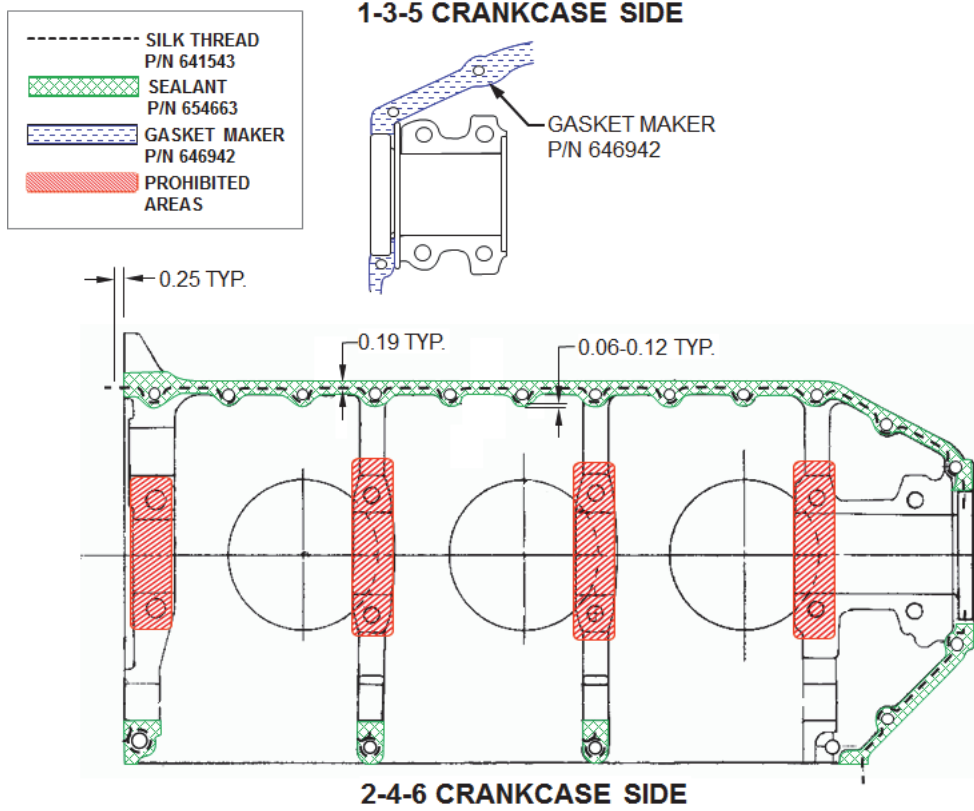

Figure 3-5. Crankcase Threading Diagram - O300

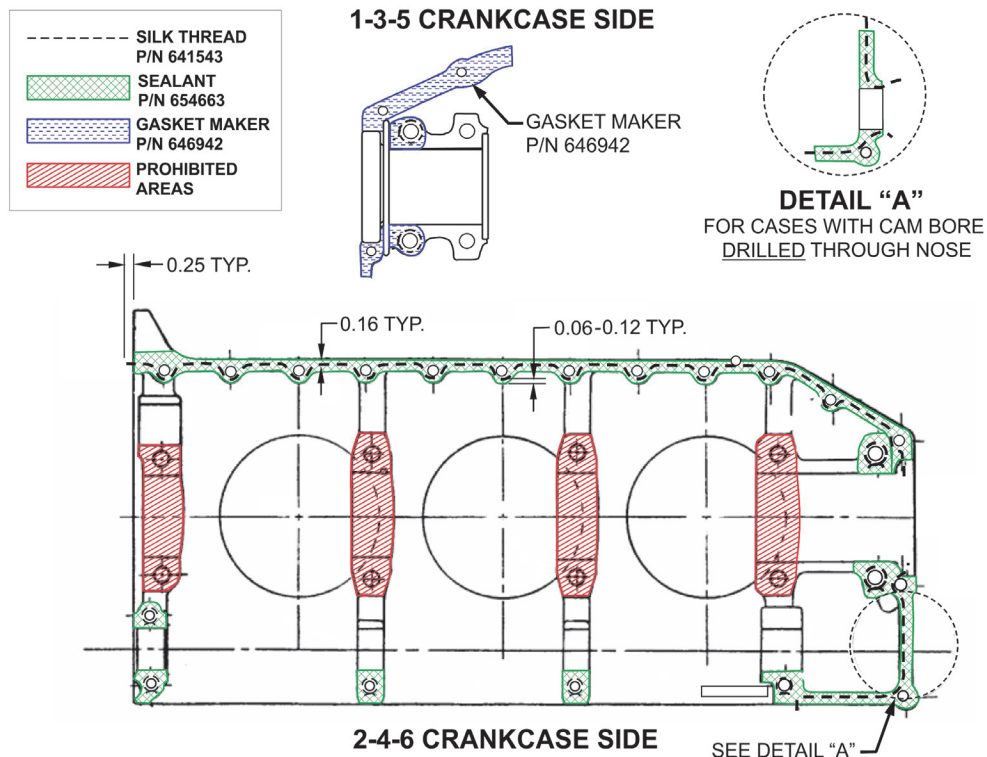

Figure 3-6. Crankcase Threading Diagram - IO360, L/TSIO360

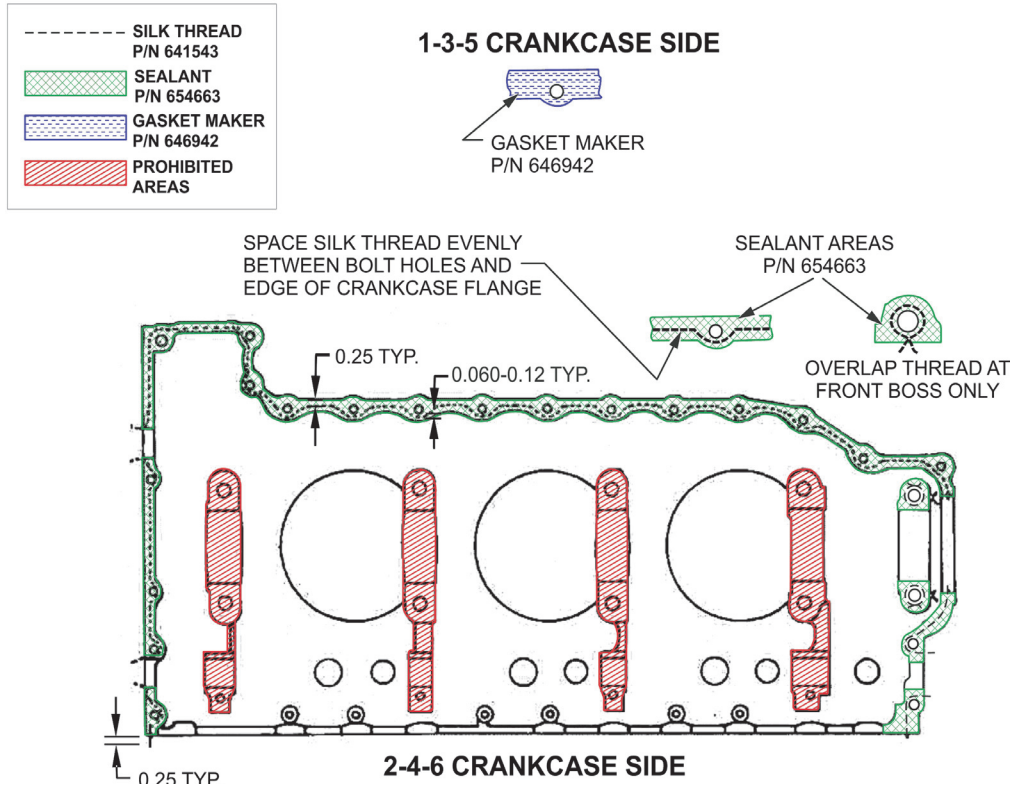

Figure 3-7. Crankcase Threading Diagram - 520/550 Permold

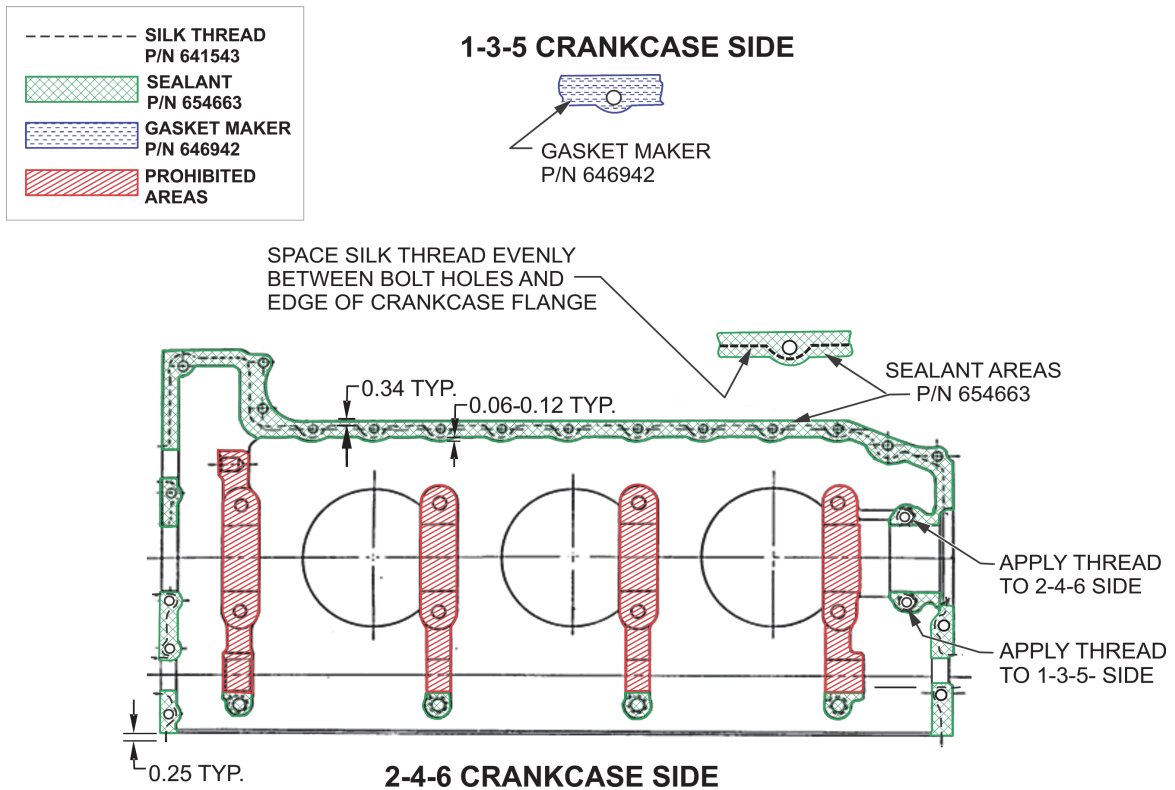

Figure 3-8. Crankcase Threading Diagram - 470/520/550 Sandcast

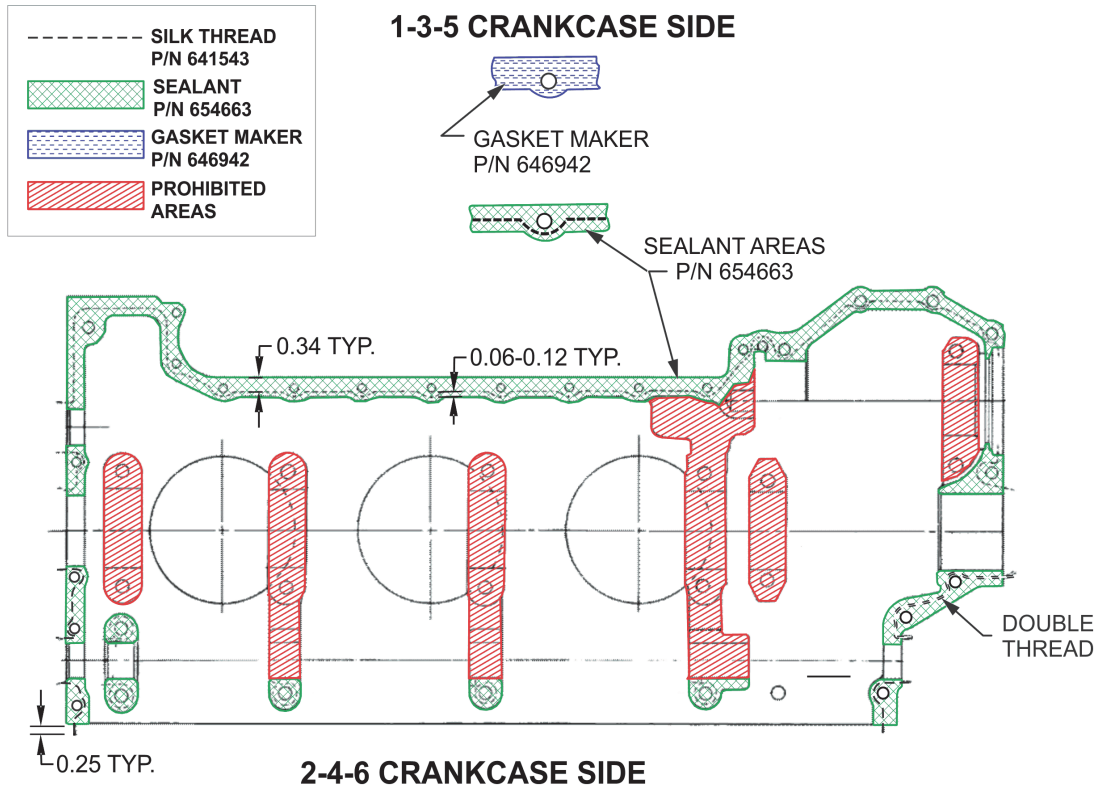

Figure 3-9. Crankcase Threading Diagram - GTSIO520



3-3.2. Scavenge Pump Body Sealant and Threading

1. Use full strength, non-thinned P/N 654663 (gasket sealant). Shake or mix well before using.

NOTE: Apply gasket sealant and threading (a continuous, single piece) only as illustrated.

2. Apply P/N 654663 (gasket sealant) to scavenge pump body according to the manufacturer's instructions only in areas where threading is indicated. When applying, use short light brush strokes until an even thin coat is obtained. The gasket sealant should be viscous enough that most of the brush marks disappear; if not, discard the old gasket sealant and reapply with new gasket sealant.

NOTE: Allow the gasket sealant to air dry to a tacky condition before applying silk threading.

3. Apply a thin translucent coat of P/N 646942 (gasket maker), not to exceed 0.010 inch thick, to areas of the starter adapter cover where gasket sealant was applied on the mating surfaces.
4. Apply and position P/N 641543 (a continuous, single piece of grade "D" silk thread) as shown by the dashed lines in Figure 3-10.
5. Assemble and torque as soon as possible in accordance with the applicable overhaul manual.

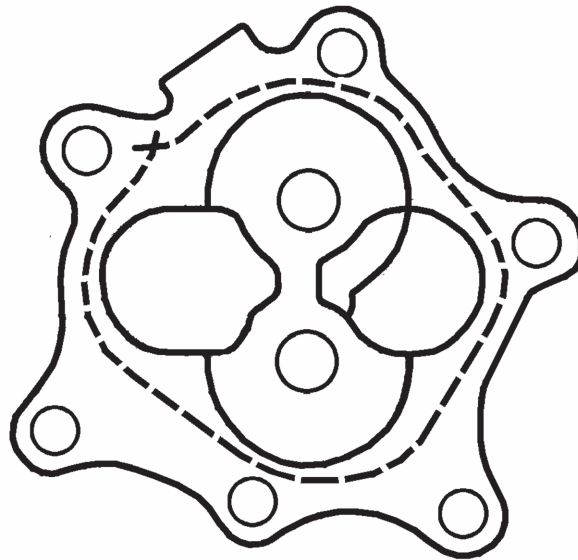

Figure 3-10. Scavenge Pump Body Threading Diagram

Applicable to scavenge pump bodies, Part Nos. 640741, 652019, 655713, used on starter adapters 642087 & corresponding 0.015 oversize adapters



3-3.3. Oil Pump Assembly Sealant and Threading

1. Use full strength, non-thinned P/N 654663 (gasket sealant). Shake or mix well before using.

NOTE: Apply gasket sealant and threading (a continuous, single piece) only as illustrated.
2. Apply P/N 654663 (gasket sealant) to the oil pump housing according to the manufacturer's instructions only in areas where threading is indicated. When applying, use short light brush strokes until an even thin coat is obtained. The gasket sealant should be viscous enough that most of the brush marks disappear; if not, discard the old gasket sealant and reapply with new gasket sealant.

NOTE: Allow gasket sealant to air dry to a tacky condition before applying silk threading.
3. Apply a thin translucent coat of P/N 646942 (gasket maker), not to exceed 0.010 inch thick, to areas of the oil pump cover where gasket sealant was applied on the mating surfaces.
4. Apply and position P/N 641543 (a continuous, single piece of grade "D" silk thread) as shown by the dashed lines in Figure 3-11 through Figure 3-15.
5. Assemble and torque as soon as possible according to the overhaul manual instructions.

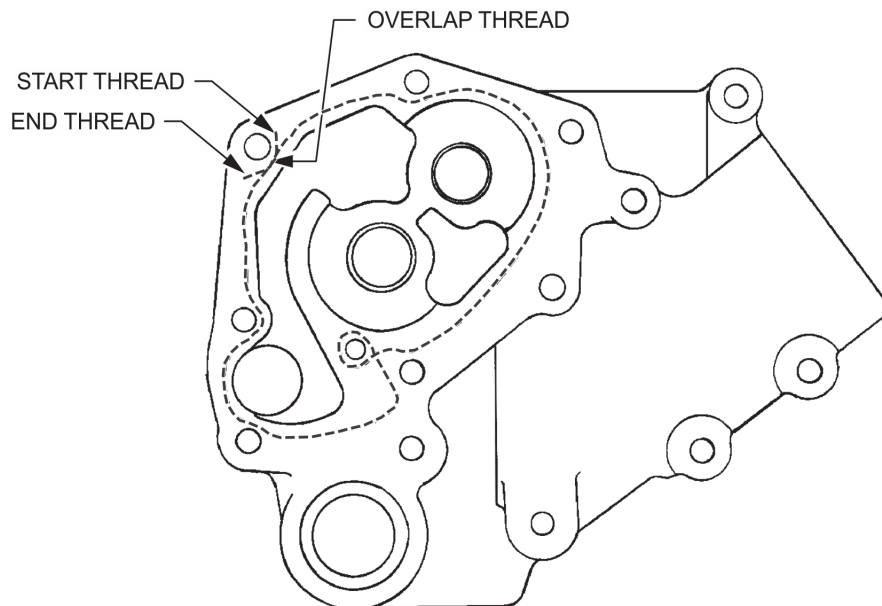

Figure 3-11. Oil Pump Assembly Threading Diagram
Applicable to oil pump assembly, Part Nos. 631713, 632481,
632563, & 641993

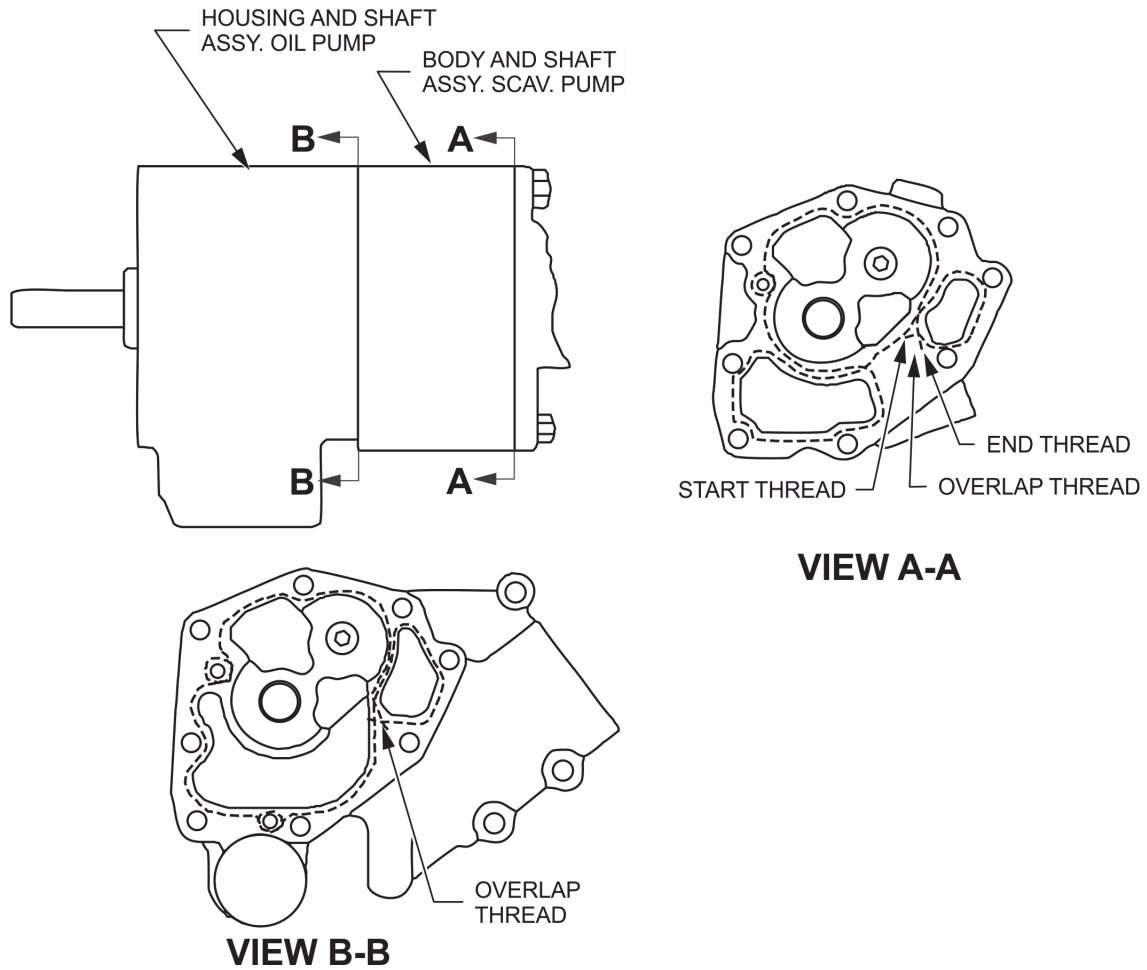

Figure 3-12. Oil Pump Assembly Threading Diagram
Applicable to oil pump assembly, Part No. 632623

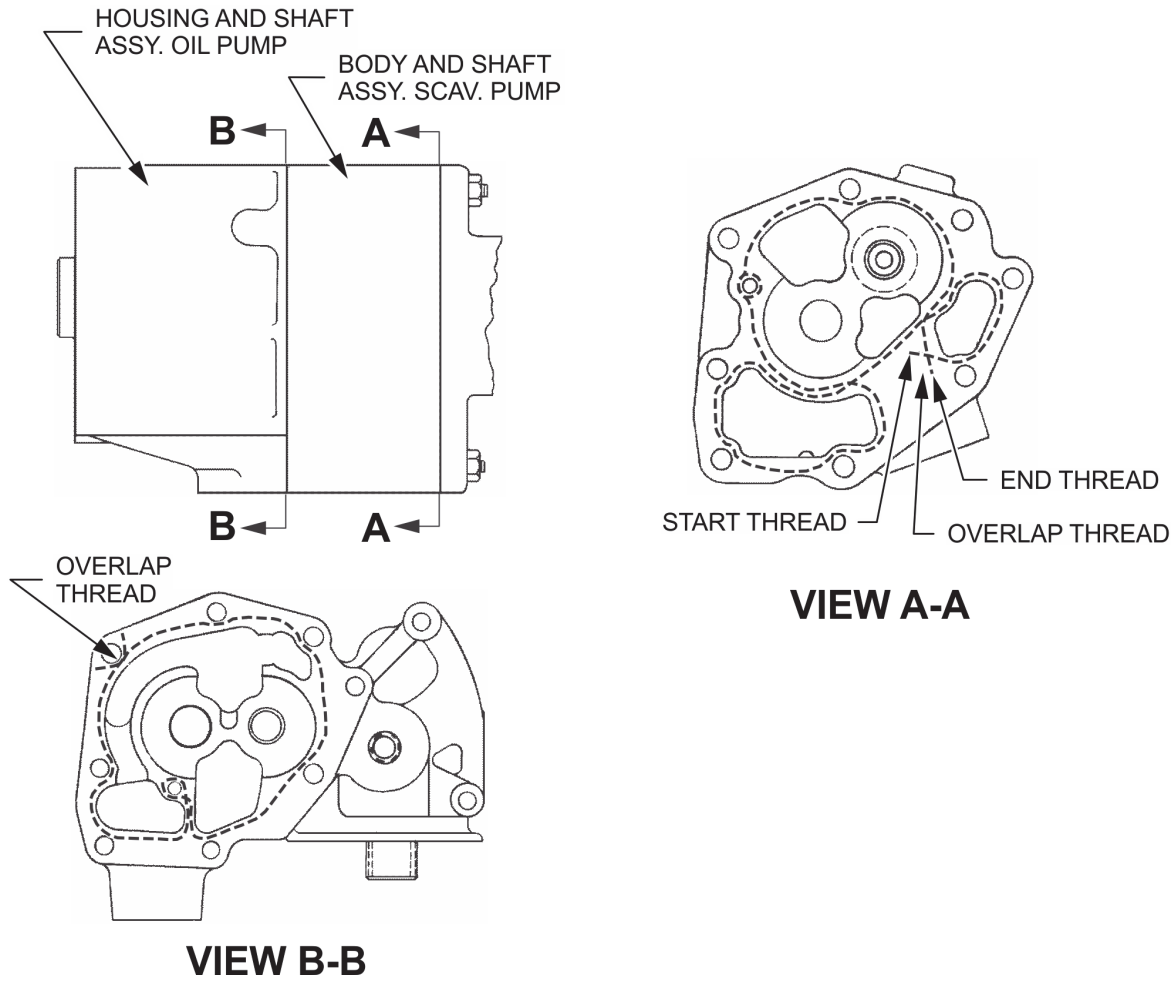

Figure 3-13. Oil Pump Assembly Threading Diagram
Applicable to oil pump assembly, Part Nos. 646194, 653536, 655121,
& 643527

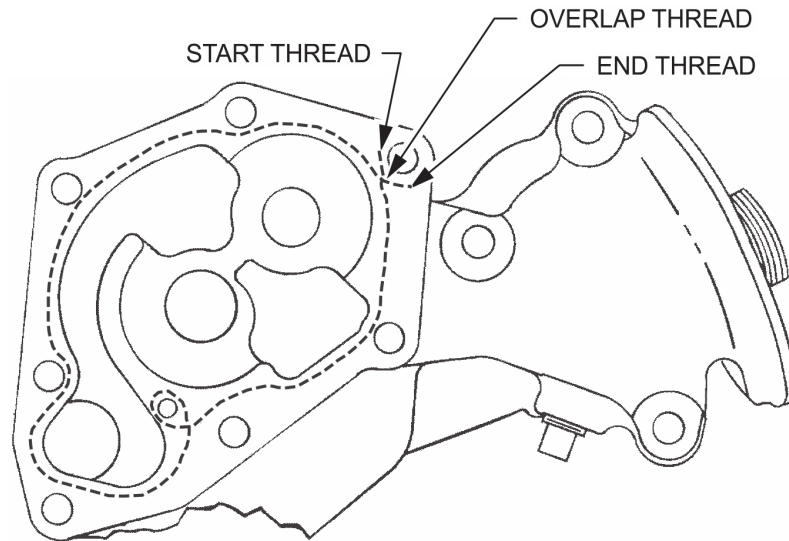

Figure 3-14. Oil Pump Assembly Threading Diagram
Applicable to oil pump assembly, Part Nos. 643716, 643717,
643743, 643778, 643779, 653494, 653538, 653542, 653542,
653553, 655117, 655119, 655123, 655124, & 655127

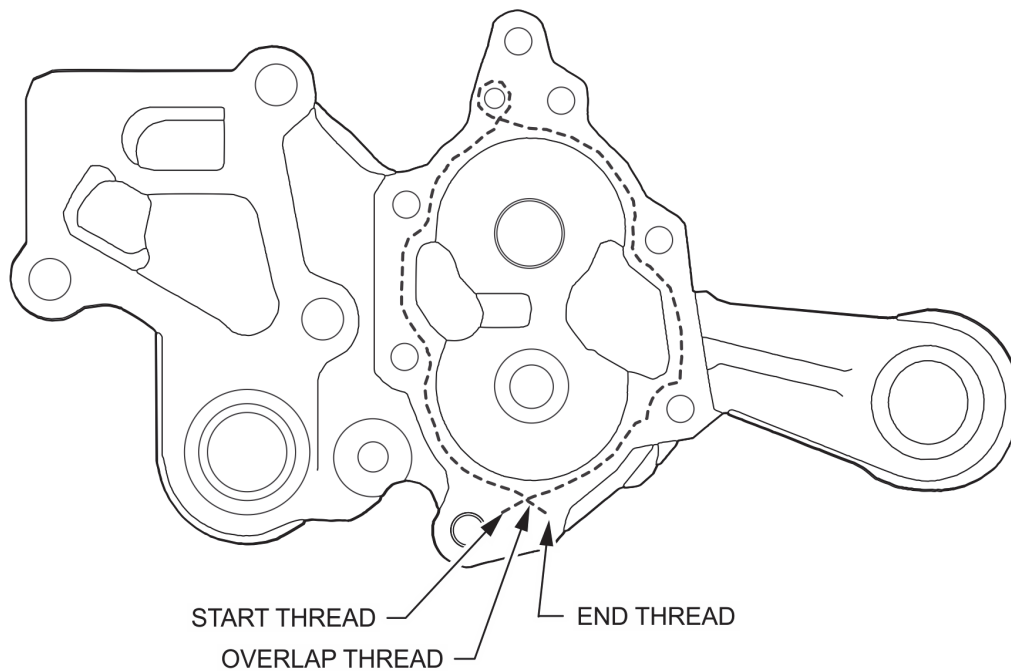

Figure 3-15. Oil Pump Assembly Threading Diagram
Applicable to oil pump assembly, Part Nos. 631149, 632970,
632977, 654437, 655349, & 655680



3-3.4. Starter Adapter Assembly Sealant and Threading

1. Use full strength, non-thinned P/N 654663 (gasket sealant). Shake or mix well before using.

NOTE: Apply gasket sealant and threading (a continuous, single piece) only as illustrated.
2. Apply P/N 654663 (gasket sealant) to the starter adapter housing according to the manufacturer's instructions only in areas where threading is indicated. When applying, use short light brush strokes until a thin, even coat is obtained. The gasket sealant should be viscous enough that most of the brush marks disappear; if not, discard the old gasket sealant and reapply with new gasket sealant.

NOTE: Allow gasket sealant to air dry to a tacky condition before applying silk threading.
3. Apply and position P/N 641543 (a continuous, single piece of grade "D" silk thread) as shown by the dashed lines in Figure 3-16.
4. Temporarily install the starter adapter to make an impression of the silk thread on the accessory case.
5. Carefully remove the starter adapter so that the shaft gear does not pull out.

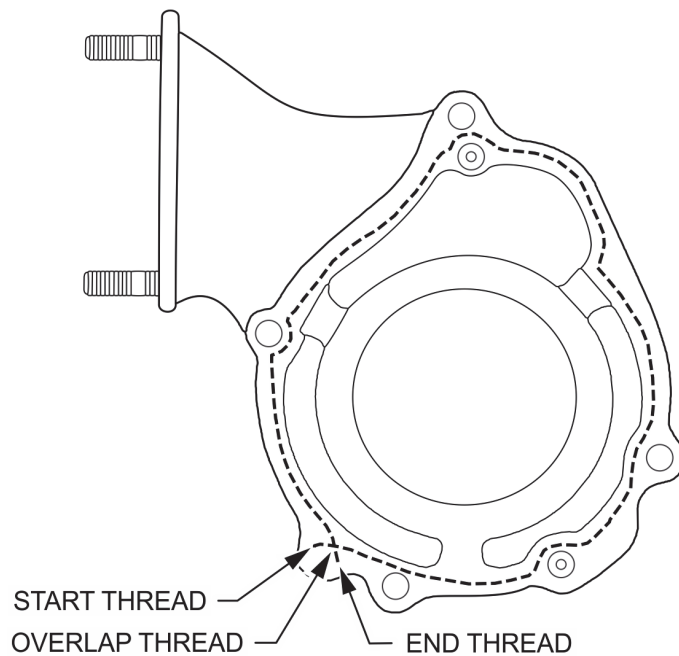

Figure 3-16. Starter Adapter Assembly Threading Diagram

Applicable to starter adapter assembly, Part Nos. 641348, 646220, & 653074

6. Inspect the thread impression for 100% contact between the starter adapter housing and accessory case.



7. Apply a thin translucent coat of P/N 646942 (gasket maker), not to exceed 0.010 inch thick, to areas of the accessory case that mate with the gasket sealant on the starter adapter housing.
8. Install and torque the starter adapter according to the instructions in the applicable overhaul manual as soon as possible.
9. Wipe excess sealant from the accessory case and starter adapter.

3-3.5. Starter Adapter Accessory Drive Cover Sealant and Threading

1. Use full strength, non-thinned P/N 654663 (gasket sealant). Shake or mix well before using.

NOTE: Apply gasket sealant and threading (a continuous, single piece) only as illustrated.

2. Apply P/N 654663 (gasket sealant) to 2-4-6 case half. Apply gasket sealant per the manufacturer's instructions only in areas where threading is indicated. When applying, use short light brush strokes until an even thin coat is obtained. The gasket sealant should be viscous enough that most of the brush marks disappear; if not, remove old gasket sealant and reapply with new gasket sealant.

NOTE: Allow gasket sealant to air dry to a tacky condition before applying silk threading.

3. Apply a thin translucent coat of P/N 646942 (gasket maker), not to exceed 0.010 inch thick, to the mating area of the accessory drive cover.
4. Apply and position P/N 641543 (a continuous, single piece of grade "D" silk thread) as shown by the dashed lines in Figure 3-17.
5. Assemble and torque as soon as possible according to the overhaul manual instructions.

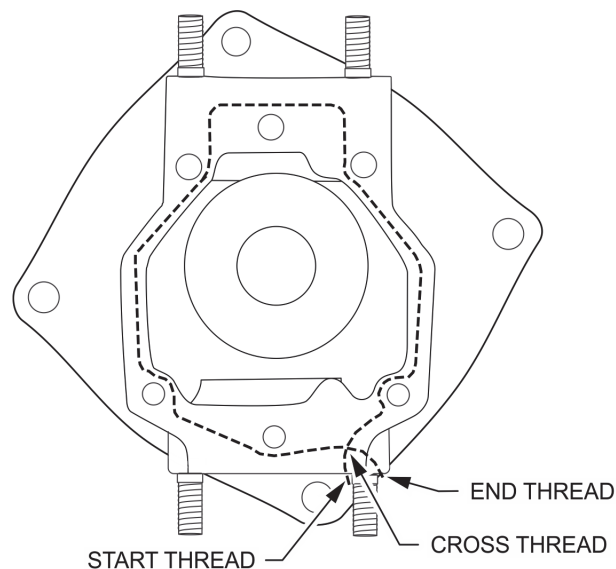

Figure 3-17. Accessory Drive Cover Threading Diagram



Intentionally Left Blank



Chapter 4. Airworthiness Limitation Section

Each aircraft engine certified under Title 14 Code of Federal Regulations (CFR), § 33 Amendment 9 or later requires an Airworthiness Limitation Section in the principal (primary) Instructions for Continued Airworthiness that is segregated and clearly distinguishable from the rest of the manual. Consult Section 1-1.1 of this manual to determine the part number of the primary ICA for your engine.

Continental Motors engine Instructions for Continued Airworthiness with an initial publication date later than 1984 contain an Airworthiness Limitation Section.

Continental Motors piston aircraft engines certified under CAR 13 or prior to 14CFR § 33 Amendment 9 predate the Airworthiness Limitation Section requirement; consult the latest revision of Continental Motors SIL97-1 for information regarding engine Instructions for Continued Airworthiness that do not contain an Airworthiness Limitation Section.



Intentionally Left Blank



Chapter 5. Engine Removal & Installation

5-1. Engine Removal

5-1.1. Tools and Consumable Supplies

WARNING

Ensure engine hoist and slings are designed to support the weight of the total engine weight, including accessories.

Use of engine lifting eyes to lift the aircraft is strictly prohibited.

CAUTION: Keep crankshaft axis horizontal during handling operations.

1. Engine Hoist (rated for 800 lbs. minimum)
2. Two (2) engine slings (rated for 800 lbs. minimum)
3. Engine Transport Stand
4. Catch Basins (oil and fuel)
5. Tank Sprayer with Stoddard Solvent (exterior engine cleaning)

5-1.2. Engine Removal Procedure

Reference the principal ICA (Section 1-1.1) for the engine being installed for removal procedures.



5-2. Engine Installation

5-2.1. Common Tools and Consumable Supplies

WARNING

Ensure engine hoist and slings are designed to support the weight of the total engine weight, including accessories.

Keep crankshaft axis horizontal during handling operations.

1. Engine Hoist (rated for 800 lbs. minimum)
2. Two (2) engine slings (rated for 800 lbs. minimum)
3. Oil conforming to SAE J1966 (break-in oil, non-dispersant mineral oil) MIL-C-6529 Type II (Fly-away oil)
4. Ashless dispersant oil conforming to SAE J1899
5. MIL-P-46002, Grade 1 oil
6. Approved fuel for the engine model (see Section 7-2.2) or Type Certificate Data Sheet (TCDS)
7. Spark plugs and copper gaskets
8. MS20995 Type A Safety Wire (0.020" and 0.032")
9. Cable ties or nylon lacing cord
10. Bladder-type pressure pot (at least 1 gallon capacity)
11. Type 1 flammable fuel container (at least one gallon capacity)
12. Clean fuel hoses (fuel system setup)
13. AN union fittings (fuel system setup)
14. Rubber grommets (bulkhead and baffle pass-through)
15. MS-122AD Spray (procured from Miller-Stephenson)
16. Spark Plug Manufacturer's recommended spark plug thread lubricant
17. Part No. 646940, Loctite Hydraulic Sealant
18. Part No. 646943, Anti-seize Lubricant
19. Loctite Part No. 592 Pipe Sealant
20. Other supplies required by the aircraft manufacturer's instructions.

5-2.2. Engine Receipt and Handling

When the engine arrives, inspect the crating for damage. If the engine crating appears damaged, notify the freight shipping company for resolution. If the crating appears intact, proceed to Section 5-2.3.



5-2.3. Uncrating the Engine

1. Remove the lag screws attaching the wooden cover to the base.
2. Lift the wooden cover and remove it.
3. Open the plastic bag wrapped around the engine.
4. Inspect the engine according to the “Acceptance Inspection” criteria in Section 5-2.5.

NOTE: The engine is preserved for long term storage at the factory; if it is not immediately installed after acceptance, refer to the “Engine Preservation and Storage” instructions in Chapter 9 for ongoing corrosion protection instructions. Environmental conditions (humidity), seasonal changes, and engine usage influence susceptibility to corrosion. In areas of high humidity, corrosion can occur within two days of uncrating the engine. The owner/operator is responsible for recognizing the risk of corrosion and taking the appropriate precautions.

5. If the engine will be stored for any length of time, refer to the “Engine Preservation and Storage” instructions in Section 9.

5-2.4. Crating an Engine for Shipping

1. Lower the engine onto the container base.
2. Attach the engine using shock mounts and bolts.
3. Cover the engine with a plastic bag.
4. Install and attach the container cover to the base.

5-2.5. Acceptance Inspection

CAUTION: If hidden engine damage or corrosion is discovered, contact Continental Motors (see “Contact Information” in Section 1-3). Do not install or place a damaged/corroded engine in storage.

1. Verify the engine serial number and model number on the engine nameplate are the same as specified in the engine logbook and the packing slip.
2. Inspect the engine for signs of damage or corrosion.
 - a. If the engine exhibits no sign of damage or corrosion, proceed with installation.
 - b. If damage or corrosion is discovered, contact the supplier of the engine for disposition.



5-2.6. Engine Transport

Refer to the “Engine Installation Drawings” in the primary ICA (Section 1-1.1) for lifting eye locations.

CAUTION: Do not allow chains to become entangled on the engine or its hardware. Ensure the area is clear when lifting the engine. Do not allow the front, rear, sides or bottom of the engine to strike any obstructions as the extreme weight may damage the engine or its components.

1. Attach a hoist to the engine lifting eyes located at the top of the crankcase backbone.
2. Take up slack on the hoist prior to loosening the engine mount bolts; remove the bolts from the shipping shock mounts.
3. Lift the engine and install it on a transportation stand or dolly.

5-2.7. Engine Installation Procedures

Refer to the engine installation instructions in the primary ICA for the engine being installed when installing a like engine as a replacement. For engines being installed for the first time in a new aircraft, refer to the engine installation manual.

NOTE: The installer is authorized to reposition engine component fittings, if necessary, to mate with the aircraft interfaces, See Section 5-2.8.



5-2.8. Engine Adjustments and Component Replacement by OEMs and STC Converters

Continental Motors supplies engines to aircraft Original Equipment Manufacturer's (OEM) and STC Converters. These engines have been assembled, tested and inspected in accordance with Continental Motors FAA approved quality system standards and FAA issued Production Certificate.

NOTE: Fitting orientation is determined at the time engine model specification is designated for the aircraft application. If fitting orientation adjustment is required for every engine installation, a model specification change request may be more appropriate than repeated repositioning of fittings.

Normally, only minor adjustments to the engine fuel system will be necessary at engine installation (Reference Section 6-4.7, "Engine Operational Check"). Occasionally, minor adjustment may be necessary to other engine systems, components, or to position fittings for best routing and fit.

Continental Motors hereby authorizes the specified adjustment and component replacements listed in Table 5-1 to OEM and STC Converters who are approved by the FAA as an aircraft production facility or FAA Approved modification facility.

Personnel performing the specified adjustment and component replacements must be a licensed Airframe and Power Plant mechanic or be approved by the OEM or STC Converter facilities quality assurance to be capable of performing the specific task. Work shall be performed in accordance with applicable continued airworthiness instructions including but not limited to the engine Installation Manual, Maintenance and Overhaul (or Overhaul) Manual, Service Documents.

All work performed in accordance with these instructions must be documented by the individual performing the task on the OEM or STC Converters FAA approved Quality Inspection Document and traceable by engine and/or aircraft serial numbers.

Adjustments and or replacements accomplished in accordance with these instructions must be documented by the OEM on the aircraft production paper work. Additionally, the OEM must provide Continental Motors notification of adjustments and replacements accomplished in accordance with these instructions. If a component part is replaced, the OEM must provide the part number and serial number of the component removed and the part number and serial number of the component installed. Return of any removed component is to be coordinated with Continental Motors via the OEM/Converter Customer Portal.



Table 5-1. Authorized Adjustments and Replacements

Authorized Adjustments	Authorized Replacements
Accessory Drive Belts	Alternator
Baffles and Baffle Seals	Baffles
Engine Control Cable Support Brackets and Attachment Points	Carburetor and/or Carburetor Airbox
	Crankshaft/Propeller Shaft Nose Oil Seal
Fluid Lines and Hoses, Attachment and Support	Engine Mount Legs
Fuel Pump, Throttle & Fuel Control Unit Fittings	Exhaust System Components
Fuel Drain Fitting(s)	Fuel Injector Nozzles
Fuel Inlet Fitting	Fuel Injection Lines and Hoses
Fuel Return Fittings	Ignition Harness
Fuel Vapor Return Fittings	Manifold Valve
Fuel System Adjustment	Magnetos
Induction System Hose Clamps	Magneto Sensor(s)
Magneto Orientation (positioning)	Oil Coolers and adapter plates
Magneto Timing to Engine	Oil Filters
Oil Supply and Return Fittings	Oil Screens
Reference Air Fittings	Oil Pump
Worm Screw Clamps	Oil Sump and Gasket
	Spark Plugs
	Starter Adapter Assembly
	Starter Motor
	Turbocharger and Turbocharger System Components



5-2.9. Engine Pre-oiling

WARNING

Do not use the starter to rotate the engine during engine pre-oiling. Persistent engagement of the starter to rotate the crankshaft will exceed the starter duty cycle and may result in premature starter failure.

1. Install and torque the spark plugs and ignition lead wires according to the “Ignition System Maintenance” instructions in Section 6-4.9.
2. Verify lubrication lines, fittings, hoses, screens, and filters are in place prior to pre-oiling.
3. Obtain a 1-gallon capacity bladder-type pressure pot with an output pressure of 50 psi (not to exceed 60 psi).
4. Connect the pre-oiler supply hose to the engine oil pressure output (fitting). It may be necessary to disconnect the aircraft oil pressure sensor fitting according to the aircraft manufacturer's instructions.
5. Remove the rocker covers.
6. Open the pre-oiler valve and monitor the rocker arms for oil flow. Depending upon oil temperature, it may take several minutes to see an indication of oil flow.
7. Close the pre-oiler valve upon verification of oil flow at the rocker arms.
8. Install the rocker covers with new gaskets according to the “Cylinder Installation” instructions in the primary ICA (Section 1-1.1). Torque the rocker cover fasteners to Appendix B specifications.
9. Disconnect the pre-oiler supply hose and cap; connect the aircraft oil pressure sensor to the engine oil pressure output according to the aircraft manufacturer's instructions.

WARNING

Do not operate the engine unless the oil is properly serviced.

10. Check the oil level in the sump using the oil gauge rod (dip stick). Verify the engine oil is at the proper level according to instructions in the primary ICA (Section 1-1.1) for the engine model.



Intentionally Left Blank



Chapter 6. Engine Inspection and Service

6-1. Engine Inspection Introduction

Inspections described in this chapter apply only to the Continental Motors engines covered by this manual. Perform the engine inspections according to the instructions provided. Perform aircraft inspections according to the aircraft manufacturer's instructions. Refer to the following sections:

- Section 6-2, “Inspection and Maintenance Schedule”
- Section 6-3, “Time Between Overhaul”
- Section 6-4, “Scheduled Inspections”
- Section 6-5, “Unscheduled Maintenance”
- Section 6-6, “Inspection Checklists”

Some inspections are at predetermined intervals (scheduled) while others are based on circumstance (unscheduled). Engine servicing is performed at scheduled intervals but may also be performed “on condition.” The first part of this chapter is devoted to scheduled maintenance intervals and associated procedures; unscheduled maintenance instructions follow the scheduled maintenance instructions.

NOTE: Discrepancies discovered by the person conducting the scheduled or unscheduled inspections, even if the discrepancy is not an itemized inspection item, should be corrected upon discovery. Fuel and oil system contamination affects engine performance and service life. If oil or fuel system contamination is discovered, do not limit the correction to the symptom; isolate and correct the source of the contamination, including any residual material left in the engine by the source of the contamination.

6-2. Inspection and Maintenance Schedule

Unless another FAA-approved Inspection Program is established, the Engine Inspection and Maintenance Schedule shows the inspections for the subject engines covered by this manual in their original type design. The inspections described in this chapter apply to the engine and not to the aircraft. Refer to the Aircraft Manufacturer’s manual for airframe inspection requirements.

The inspections are progressive; commencing from the date the engine is placed in service. The inspection intervals are tracked by Engine Log entries and designated by hours of operation or calendar time, whichever occurs first. Inspection techniques must be executed consistently for reliability.

6-3. Time Between Overhaul

Continental Motors (CM) provides operational limitations and instructions for your engine along with the requirements for continued airworthiness as specified in the engine Operator Manuals, Maintenance Manuals, Overhaul Manuals, and Service Documents. The Time Between Engine Overhaul provided in this document applies only to engines that have been operated and maintained in accordance with these instructions. Engine mounted components and accessories require overhaul at the same hourly and calendar intervals as the engine, unless otherwise specified by the component or accessory manufacturer.



Engine Inspection and Service

An engine's published TBO DOES NOT mean that every engine will operate the number of hours or years listed without requiring component replacements and/or unscheduled maintenance events. Noncompliance with CM instructions for continued airworthiness, operational and/or environmental factors may necessitate repair or replacement of the engine, engine components and accessories earlier than the published TBO.

TBO periods were established on most CM engines beginning in the 1960s. Since that time, CM has made significant engineering improvements to virtually all major engine components. CM has refined manufacturing processes and implemented computer numerical controlled (CNC) machining tools enabling CM factory engines to meet higher standards than possible when the engines were originally granted FAA Type Certificates. These improvements have enabled CM to increase TBO limits for many of our new and rebuilt engines.

CM recommends the following factors be used, along with the engine's published TBO, to determine the engine's continued airworthiness:

1. Environmental corrosion occurs internally and externally on an engine. This naturally occurring process can affect continued airworthiness of the engine and engine mounted components or accessories. Regardless if the engine has been operated regularly or has been in storage; gaskets, seals, and synthetic and natural rubber goods deteriorate over time. Replace or overhaul the engine upon accumulating the operating hours specified in Table 6-1, or twelve (12) years after being placed in service, whichever occurs first.
2. For engines used in aerial spraying, TBO is 1200 hours or twelve (12) years whichever occurs first.
3. Engines used in parachute jumping, glider towing, banner towing, blimp propulsion, or other unusually stressful applications may require more frequent overhauls than listed.
4. The quality of parts, accessories and workmanship utilized during routine maintenance, engine top overhaul and major overhaul has a direct effect on the service life of the engine. Also, the maintenance and condition of engine-related components - including, but not limited to, propeller, propeller governor, vacuum pump, gear driven alternator, mount, baffles, instrumentation, and controls has a direct effect on engine durability. The TBO periods listed are predicated on the engine having been maintained according to the Instructions for Continued Airworthiness, (ICA) accepted by the FAA, specified in the engine Maintenance Manual, Overhaul Manual, and Service Documents, and operated within the limitations published in the engine operating instructions or the aircraft manufacturer's Aircraft Flight Manual / Pilot's Operating Handbook (AFM / POH).
5. Continental Motors does not provide a TBO for engines that have been:
 - Assembled with parts not supplied by Continental Motors
 - Assembled with parts that do not conform to the original FAA approved type design for the engine
 - Modified from the original type certificate configuration



- Overhauled or repaired in a manner that is inconsistent with the specifications, limits, and instructions provided in the CM Instructions for Continued Airworthiness and FAA Airworthiness Directives
6. The “Hobbs Meter” is commonly used by the aviation industry as an acceptable device to record time elapsed while electrical power is applied to the device. The conditions under which the Hobbs Meter records operation vary widely within the aviation industry. Continental Motors does not specify a method to record engine operating hours, rather, Continental Motors defers to the end application installer.

NOTE: TBO periods specified in this document are only estimates and do not reflect warranty periods. For engine warranty coverage, refer to the original Aircraft Engine Warranty received with the engine.

Table 6-1. Engine Time Between Overhaul (TBO)

ENGINE MODEL	SEE NOTE	HOURS/YEARS	
		ENGINE S/N BEFORE 1006000	ENGINE S/N 1006000 AND LATER
A65, A75 and C75, C85, C90 Series	1	1800/12	
O-200-A, B	1, 2	1800/12	2000/12
O-200-D	1	2000/12	2200/12
IO-240-A, B	1, 2		
IOF-240-B	1, 2		
IO-346-A	1	1500/12	
C125, C145 Series and O-300-A, B, C, D	1	1800/12	
GO-300-A, C, D, E	1	1200/12	
IO-360-A, AB, B, C, D, G, H, J, K	1	1500/12	
IO-360-CB, DB, GB, HB, JB	1, 2	1500/12	1700/12
IO-360-AF, ES, KB	1, 2	2000/12	2200/12
TSIO-360-A, AB, B, C, D, E, F, H	1	1400/12	
LTSIO-360-E	1		
TSIO-360-CB, DB, HB, JB	1, 2	1400/12	1600/12
L/TSIO-360-EB, FB, GB, KB, LB, MB, RB, SB	1, 2	1800/12	2000/12
E165, E185, E225 Series	1	1500/12	
O-470-A, B, E, G, N, P	1		
O-470-J, K, L, M, R, S	1, 2	1500/12	1700/12
O-470-U	1, 2, 3	2000/12	2200/12
IO-470-C, D, E, F, G, H, J, K, L, M, N, P, R, S, U, V, VO	1, 2	1500/12	1700/12
TSIO-470-B, C, D	1	1400/12	
IO-520-B, BA, C, M	1	1700/12	
IO-520-A, BB, CB, D, E, F, J, K, L, MB	1, 2	1700/12	1900/12
L/IO-520-P	1, 2	2000/12	2200/12



Table 6-1. Engine Time Between Overhaul (TBO)

ENGINE MODEL	SEE NOTE	HOURS/YEARS	
		ENGINE S/N BEFORE 1006000	ENGINE S/N 1006000 AND LATER
GTSIO-520-F, K	1	1200/12	
GTSIO-520-C, D, H	1, 4	1600/12	
GTSIO-520-L, M, N	1		
TSIO-520-B, D, E, J, K, L, N	1	1400/12	
TSIO-520-BB, C, DB, EB, G, H, JB, KB, LB, M, P, R, T	1, 2	1400/12	1600/12
TSIO-520-NB	1, 2,	1600/12	1800/12
TSIO-520-M, P, R	1, 2, 5		
TSIO-520-AF, CE, UB, VB, WB	1, 2		
L/TSIO-520-AE	1, 2	2000/12	2200/12
TSIO-520-BE	1, 2		
IO-550-A, B, C, D, E, F, L	1, 2	1700/12	1900/12
IO-550-G, N, P, R	1, 2	2000/12	2200/12
IOF-550-N	1, 2		
TSIO-550-B, E	1, 2	1600/12	1800/12
TSIO-550-C, G, K, N	1, 2	2000/12	2200/12
TSIOF-550-D, J, K, P	1, 2		
TSIOL-550-A, B, C	1	2000/12	

1. If an engine consistently accumulates 40 or more hours per month since being placed in service, add 200 hours to recommended TBO.
2. Engines with Serial Number 1006000 or higher include an additional 200 hours to TBO (as noted in Table 6-1, column 3).
3. Applies to: new and rebuilt O-470U Model Specifications 11, 12, 13, 14, 17, 18, and subsequent numbers manufactured, new or rebuilt, or overhauled (2002 or later).
4. Applies to GTSIO-520-C, D, H engine models listed utilizing cylinder part number 653453, or superseding (cylinder production released APRIL 1993-verify part number on cylinder flange). Also, all parts must be replaced as directed by the applicable current service bulletins, illustrated parts catalogs, and overhaul manuals. A log book entry is required.
5. Applies to new and rebuilt TSIO-520-M Spec. 6, 7, and 8; TSIO-520-P Spec. 5 and 6; TSIO-520-R Spec. 7, 9, 10, and 11, or new and rebuilt TSIO-520-M, P, and R model engines with subsequent specification numbers.



6-4. Scheduled Inspections

Scheduled inspections are performed at predetermined intervals to verify the system and subsystem integrity; Scheduled inspections and maintenance are intended to enhance serviceability by discovering minor discrepancies and correcting them before the condition degrades. Scheduled inspections are based on calendar days or operating hours or a combination of both. Scheduled maintenance and service tasks are included in the inspections for convenience.

NOTE: Inspection intervals listed in Section 6-2 apply to conventional, spark ignited engines equipped with magnetos. For FADEC equipped engines, reference the inspection and maintenance instructions in the primary ICA (**Ref: Section 1-1.1**).

Table 6-2. Engine Inspection and Maintenance Schedule

NOTE: If operating hours and a calendar period are specified, perform the inspection coincident with the earliest occurrence.			
Interval		Task	Reference
Cumulative Operating Hours	Calendar		
5	---	Drive Belt (optional equipment) Tension Check (One Time)	Section 6-4.1
10	---	Hartzell Alternator Initial Inspection (One Time)	Section 6-4.1
25	6 months	Initial operation inspection and service after placing a new, rebuilt, or overhauled engine in service, including cylinder replacement. Repeat this inspection after each 25 hours of operation until oil consumption stabilizes.	Section 6-4.2
25	4 months	Oil Change (with integral oil screen)	Section 6-4.8
50	4 months	50-Hour engine inspection and service	Section 6-4.3
100	Annual	100-hour engine inspection and service	Section 6-4.4
---	Annual	Replace FADEC Backup Battery	Primary ICA
100	Annual	Clean FADEC fuel distribution block	Primary ICA
100	Annual	Clean FADEC fuel filter	Primary ICA
300	Annual	Clean fuel injector nozzles ¹	Section 6-4.4
500	4 years	Magneto inspection ¹	Section 6-4.4
500	---	500-hour inspection and service	Section 6-4.5
NOTE: At engine TBO (Section 6-3), engine accessories, including the starter, alternator, magneto, fuel system and turbochargers must be replaced with new assemblies, factory rebuilt assemblies, or assemblies which have been overhauled according to FAA approved procedures.			

1. Not applicable to FADEC engines.



6-4.1. One Time Post - Installation Inspections

Check the tension of new drive belts after the first five hours of operation unless a shorter duration is specified in the primary ICA (**Ref: Section 1-1.1**). Adjust belt tension, as required, according to the instructions in Section 6-4.10.4, “Belt Tension Check and Adjustment.”

NOTE: Some 360 Series engines require an initial inspection of a new alternator or compressor drive belt after twenty minutes of operation. Refer to the primary ICA to verify inspection belt tension inspection interval.

1. Perform a visual inspection of the alternator(s) and associated wiring and hardware after the first ten hours of operation, unless the primary ICA (**Ref: Section 1-1.1**) specifies an earlier inspection period.
2. Inspect the bolts and safety wire application.
3. Look for signs of arcing or overheating.
4. Check the cooling duct connections for cleanliness and security.
5. Check terminals and insulators for tightness and condition.



6-4.2. 25-Hour Initial Operation Inspection

Frequency

- Twenty-five (25) hours or six months (whichever occurs first) after:
 - Placing a new, rebuilt, or overhauled engine in service
 - Replacement of one or more engine cylinder and/or piston rings
- After every 25 hours of engine operation until oil consumption stabilizes

WARNING

Turn the Ignition Switch OFF and disconnect engine electrical power before commencing maintenance or inspections. Confirm continuity between the magneto capacitor and aircraft ground to prevent accidental engine start during maintenance. Do not stand or place equipment within the arc of the propeller.

Procedure

WARNING

Correct all fuel or oil leaks. Flammable petroleum products may ignite if exposed to an ignition source.

1. Perform a visual inspection according to instructions in Section 6-4.6; correct any discrepancies.

NOTE: For FADEC engines, perform an “Engine Operational Check” according to instructions in the primary ICA rather than a Ground Engine Run.

2. Perform a normal “Engine Start” and “Ground Run-up” according to instructions in the AFM/POH. When the engine reaches normal operating temperatures, check the following:

a. Idle RPM AFM/POH

b. Idle Mixture Rise AFM/POH

c. Acceleration Smooth from IDLE to Wide Open
If acceleration is rough or the Idle RPM or Idle Mixture Rise is outside the parameters specified in Section 6-4.7.1, perform an “Engine Operational Check” according to Section 6-4.7 and adjust the fuel system accordingly.

3. Determine oil consumption by reviewing engine log book service record. Calculate the brake specific oil consumption (BSOC) using the formula in the primary ICA (**Ref: Section 1-1.1**). If oil consumption exceeds the maximum limit, consumption is excessive, proceed to step 3a. If consumption is acceptable, proceed to step 4.

a. If oil consumption is excessive, troubleshoot according to the instructions in Chapter 8, “Troubleshooting.”

b. Perform a “Cylinder Borescope Inspection” according to the instructions in Section 6-4.11.3.



Engine Inspection and Service

- c. Service the engine with mineral oil conforming to SAE J1966 rather than the ashless dispersant oil specified in step 4. Repeat this inspection after 25 hours of operation.
4. Change the oil and filter according to instructions in Section 6-4.8.2, “Oil Change.” Fill the oil sump to the proper capacity for the engine model (See engine specification section of Overhaul Manual (**Ref: Section 1-1.1**)) with fresh, ashless dispersant aviation engine oil conforming to SAE J1899 (Section 3-1).
5. Remove and inspect the induction air filter. Clean or replace the filter media if necessary. Verify the induction air filter is installed properly; tighten any loose fastening hardware. With the induction air filter installed, verify the induction air filter retainer is properly installed and the attaching hardware is secure in accordance with the aircraft manufacturer's instructions.
6. Inspect the induction/cylinder drains (if equipped) according to the instructions in Section 6-4.20.
7. For any other optional engine accessories, refer to the accessory manufacturer’s maintenance instructions for inspection criteria.

6-4.3. 50-Hour Engine Inspection

Frequency

- 25 hours after the 25 hour Initial Operation Inspection
- After every 50 hours (or four months) of engine operation

WARNING

Turn the Ignition Switch OFF and disconnect engine electrical power before commencing maintenance or inspections. Confirm continuity between the magneto capacitor and aircraft ground to prevent accidental engine start during maintenance. Do not stand or place equipment within the arc of the propeller.

Procedure

WARNING

Correct all fuel or oil leaks. Flammable petroleum products may ignite if exposed to an ignition source.

1. Perform a “Visual Inspection” according to instructions in Section 6-4.6; correct any discrepancies.

NOTE: For FADEC engines, perform an “Engine Operational Check” according to instructions in the primary ICA rather than a Ground Engine Run.
2. Perform a normal “Engine Start” and “Ground Run-up” according to instructions in the AFM/POH. When the engine reaches normal operating temperatures, check the following:
 - a. Idle RPM..... AFM/POH
 - b. Idle Mixture Rise AFM/POH



- c. Acceleration Smooth from IDLE to Wide Open
If acceleration is rough or the Idle RPM or Idle Mixture Rise are outside the normal operating parameters specified in the primary ICA (**Ref: Section 1-1.1**), perform an “Engine Operational Check” according to the instructions in Section 6-4.7.
- 3. Establish and oil analysis profile by collecting an oil sample according to the instructions in Section 6-4.8.4, “Oil Sample Collection” and Section 6-4.8.5, “Oil Trend Monitoring and Spectrographic Oil Analysis.”
- 4. Change the engine oil and filter according to the Section 6-4.8.2, “Oil Change.” Fill the oil sump to the proper capacity for the engine model (**Ref: Section 1-1.1**) with fresh, ashless dispersant aviation engine oil conforming to SAE J1899 (Section 3-1).
- 5. Perform an “Induction System Inspection” according to Section 6-4.14.
- 6. For applicable turbocharged engines, lubricate the wastegate butterfly valve and clean the oil supply check valve according to the instructions in Section 6-4.21 and Section 6-4.21.1, respectively.
- 7. Inspect the cylinder drains according to the instructions in Section 6-4.20.
- 8. If a battery serves as the FADEC secondary power source, perform the “FADEC Backup Battery Inspection” according to instructions in the primary ICA.
- 9. For any other optional engine accessories, refer to the accessory manufacturer’s maintenance instructions for inspection criteria.

6-4.4. 100-Hour (Annual) Engine Inspection

Frequency

The 100-Hour Inspection is accomplished under two circumstances:

- After every 100 hours of accumulated engine operation
- Annually, if the engine did not accumulate 100 hours of operation during the calendar year since the last 100-Hour Engine Inspection.

WARNING

Turn the Ignition Switch OFF and disconnect engine electrical power before commencing maintenance or inspections. Confirm continuity between the magneto capacitor and aircraft ground to prevent accidental engine start during maintenance. Do not stand or place equipment within the arc of the propeller.

Procedure

WARNING

Correct all fuel or oil leaks. Flammable petroleum products may ignite if exposed to an ignition source.

NOTE: The fuel injector nozzles must be cleaned after the first 100-Hour Inspection after installation of a new, rebuilt or overhauled engine. Thereafter, clean the nozzles every 300 hours or annually.

- 1. Perform a “Visual Inspection” according to instructions in Section 6-4.6; correct any discrepancies.



Engine Inspection and Service

NOTE: For FADEC engines, perform an “Engine Operational Check” according to instructions in the primary ICA rather than Section 6-4.7.

2. Perform an “Engine Operational Check” according to instructions in Section 6-4.7.
3. Collect an engine oil sample according to the instructions in Section 6-4.8.4, “Oil Sample Collection” and submit it for analysis according to Section 6-4.8.5, “Oil Trend Monitoring and Spectrographic Oil Analysis.”
4. Perform the “Cylinder Inspections” according to instructions in Section 6-4.11. The cylinder inspections consist of multiple inspections and checks including Cylinder Power Stroke Area, Differential Pressure, Borescope, Baffle, Cowling, and Cylinder Mounting Deck Inspections.
5. Perform a “Crankcase Inspection” according to Section 6-4.12.
6. Perform an “Engine Mount Inspection” according to Section 6-4.13.
7. Perform an “Induction System Inspection” according to Section 6-4.14.
8. Perform an “Ignition System Inspection” according to Section 6-4.15.
9. **For the IOF-240-B engine only**, perform a “Throttle Position Switch Inspection” according to instructions in the primary ICA.
10. **For FADEC engines only**, perform a “Ground Strap Continuity Test” according to instructions in the primary ICA.
11. **For FADEC engines only**, perform a “FADEC Backup Battery Inspection” according to instructions in the primary ICA.
12. Perform an “Engine Gauge Inspection” according to Section 6-4.16.
13. Perform a “Fuel System Inspection” according to Section 6-4.17.
14. Perform an “Engine Control Linkage Inspection” according to Section 6-4.19.
15. Perform an “Induction System Drain Inspection” according to Section 6-4.20.
16. Inspect the Exhaust system according Section 6-4.21.
17. Change the engine oil and filter according to the Section 6-4.8.2, “Oil Change.” Fill the oil sump to the proper capacity for the engine model (**Ref: Section 1-1.1**) with fresh, ashless dispersant aviation engine oil conforming to SAE J1899 (Section 3-1).
18. Inspect installed accessories for mounting security, condition, and proper operation according to the aircraft maintenance manual or accessory manufacturer’s instructions. Inspect Hartzell alternator brush holders for soot accumulation. If large amount of soot is present, inspect brushes (Section 6-4.22) according to the alternator manufacturer’s ICA.

NOTE: For FADEC engines, perform an “Engine Operational Check” according to instructions in the primary ICA rather than Section 6-4.7.

19. Perform an “Engine Operational Check” according to instructions in Section 6-4.7.
20. For any other optional engine accessories, refer to the accessory manufacturer’s maintenance instructions for inspection criteria.



6-4.5. 500-Hour Engine Inspection

Frequency

- After each 500 hours of accumulated engine operation

WARNING

Turn the Ignition Switch OFF and disconnect engine electrical power before commencing maintenance or inspections. Confirm continuity between the magneto capacitor and aircraft ground to prevent accidental engine start during maintenance. Do not stand or place equipment within the arc of the propeller.

Procedure

1. Complete the “100-Hour (Annual) Engine Inspection” requirements in Section 6-4.4.

NOTE: The following step does not apply to FADEC engines.
2. Replace non-Continental magnetos with new, rebuilt, or serviceable units. Perform a 500-Hour Magneto Inspection on Continental magnetos according to the Continental Magneto Service Manual (See Section 1-2.5, “Related Publications.”)
3. Replace paper type induction air filters according to the aircraft manufacturer’s instructions, regardless of condition.
4. Perform an “Alternator Inspection” according to the instructions in Section 6-4.22. Inspect and test the alternator for proper operation.
5. For any other optional engine accessories, refer to the accessory manufacturer’s maintenance instructions for inspection criteria.



6-4.6. Visual Inspection

Frequency

- Begin any service interval with a visual inspection

Procedure

1. Verify the engine nacelle is clean and free of fuel leaks, oil leaks, dirt and debris.
2. Inspect all fuel and oil lines for signs of chafing.
3. Inspect the oil cooler and oil filter (or screen) for signs of leaks and physical discrepancies.
4. Check the following on the engine for cracks, dents, pitting or physical damage:
 - a. External cylinder barrels
 - b. Cylinder barrel fins
 - c. Areas between and adjacent to the cylinder barrel fins.
 - d. External surfaces of the cylinder head, including areas around
 - 1) Cylinder head fins
 - 2) Top and bottom spark plug bosses
 - 3) Fuel nozzle bosses
 - 4) Crankcase external surfaces
 - 5) Accessories
 - 6) Support structures adjacent to accessories

NOTE: If cylinder discrepancies are discovered during the visual inspection, perform the “Cylinder Inspections” in Section 6-4.11.

5. Check security of engine and accessory wiring harnesses, including ignition leads. Check for signs of thermal breakdown, chafing, deterioration or improper routing.
6. Replace broken or damaged cushion clamps and stressed or broken wire ties.
7. Check magnetos for external damage, cracks and mounting security. Ensure the ignition plate is securely fastened to the magneto and the harness is properly routed.
8. Inspect external drive belts for nicks, cracks and visible wear; replace belts exhibiting nicks, cracks, or visible wear. Check belt tension and adjust, as required according to instructions in Section 6-4.10.4.
9. Inspect the exposed area of the crankshaft between the crankshaft nose oil seal and the propeller flange for evidence of corrosion. If corrosion is detected, use a Scotch-Brite® pad and a no-corrosive soap solution to remove surface corrosion.
 - a. If the cleaning process eliminated the corrosion and no evidence of pitting exists, apply a generous coat of silver or aluminum paint according to the paint manufacturer’s instructions to the exposed portion of the crankshaft to prevent further corrosion.



- b. If cleaning is unsuccessful (suspected corrosion has advanced to pitting), disassemble the engine and replace the crankshaft.
10. Check electrical connectors for signs of corrosion or contamination; if external corrosion or contamination is discovered, disconnect the connectors and inspect the internal pins for corrosion or contamination.
11. Inspect installed accessories for proper mounting and security. Inspect brush holders for soot accumulation. If large amount of soot is present, inspect brushes (Section 6-4.22).

NOTE: For items 12 - 16, inspect for obvious signs of physical damage, wear or deterioration, loose or missing hardware, leaks or foreign material that may hinder normal operation. Correct any discrepancies.
12. Inspect the physical security of the fuel system.
13. Inspect the physical integrity of the induction system airbox, ducts, seals and gaskets.
14. Inspect the physical integrity of the lubrication system.
15. Inspect the physical integrity of the turbocharger and exhaust system.
 - a. Inspect the stacks, risers, elbows and transitions for burns, cracks or leaks.
 - b. Inspect turbocharger and exhaust system hardware and joints for stress.
 - c. Inspect slip joints for leaks, bulges, cracks, deformation, or hot spots.
 - d. Inspect multi-segment V-band clamp spot welds (or rivets) for cracks or physical damage.
 - 1) Inspect the corner radii of clamp inner segments for cracks with a flashlight and inspection mirror.
 - 2) Inspect the V-band clamp outer band for flatness, especially within two inches of spot-weld tabs that retain the T-bolt fastener variance must be less than 0.062 in.
 - e. Inspect the heat exchanger, if installed, seams, joints and transition slip joints for evidence of leakage or cracks using a mirror or flexible borescope. Replace any heat exchanger assembly that exhibits cracks or is suspected of leaking.
16. Repair any observable damage or deficiency before the aircraft is returned to service. Refer to Chapter 10, Non-Overhaul Repair and Replacement Procedures.



6-4.7. Engine Operational Check

WARNING

Flight is prohibited until the engine successfully completes the operational check and is released for normal operation. If, during an operational check or engine warm-up, abnormal operation is observed or leaks occur, do not take-off. Determine the cause of the problem and take corrective action.

NOTE: The following instructions apply to engines equipped with Continental Motors continuous flow fuel injection systems only. For engines equipped with a carburetor (C-75, C-85, C-90, O-200, O-300, O-470 except GCI model), a servo controlled fuel injection system (GTSIO-520-F or K, L/TSIO-360-RB, TSIO-520-WB), FADEC controlled engines (IOF-240, IOF-550, TSIOF-550), or engines modified by STC, follow the instructions in the primary ICA to verify the engine meets operational specifications.

NOTE: For TIARA engines, reference Service Document M75-3 and the primary ICA (X30144) for fuel system setup instructions.

An engine operational check must be performed after any of the following:

- Engine Installation
- Fuel Injection System parts replacement, maintenance or troubleshooting
- Post-Overhaul
- Return from storage
- After each 100-Hour/Annual

Perform the tasks listed in Table 6-3 on a newly installed, repaired or overhauled engine before the engine can be released for normal flight. Record engine operational check results on a copy of the “Engine Operational Checklist”, Table 6-26; substitute forms created by the organization performing the engine operational check may be used.

Table 6-3. Engine Operation Prerequisites

Sequence	Requirement	Section Reference
1	Prepare the engine for operation	Maintenance Preflight Inspection
2	Check Engine Operation	Engine Operational Check
3	Complete the Engine Operational Checklist	“Engine Operational Checklist” (Table 6-26)
4	Perform Flight Check	“Flight Check” in Section 7-2.4 ¹

1. and according to the AFM/POH



6-4.7.1. Fuel Injection System Specifications

NOTE: Engines may not reach rated full power RPM during ground run-up due to atmospheric, environmental, or configuration limitations. This condition is normal, occurring most often when operating naturally aspirated engines configured with a fixed pitch propeller. A correction factor must be applied to reduce the fuel pressure to the lower maximum RPM observed during fuel system adjustments on the ground. See Section 6-4.7.1.1 for RPM correction factors.

Table 6-4. Fuel System Adjustment Values

Idle and FULL POWER Fuel Pressures and Flows						
Engine ¹	Prop. RPM	Manifold Absolute Pressure (MAP)	Unmetered Pump PSI ²	Metered Nozzle PSI ³	Fuel (lbs/hr) ⁴	Fuel (gal/hr) ⁴
IO-240-A, B	1000 Table 6-6	29.5 Table 6-6	9.4- 9.8 Table 6-6	- Table 6-6	- 65 - 70	- 11.0 - 11.9
IO-346-A, B	600 2700	-	7.0 - 7.5 19.0 - 21.0	- 12.5 - 14.0	- 78 - 85	- 13.3 - 14.5
IO-360-A, AB, C, CB, D ⁵ , DB ⁵ , G, GB, H, HB	600 2800	-	7.0 - 9.0 24.0 - 27.0	- 15.8 - 18.2	- 100 - 106	- 17.0 - 18.1
IO-360-AF	600 2800	-	7.0 - 9.0 23.0 - 26.0	- 14.3 - 16.5	- 100 - 107	- 17.0 - 18.1
IO-360-ES ⁶	600 2800	-	7.0 - 9.0 23.0 - 26.0	- 14.3 - 16.5	- 100 - 107	- 17.0 - 18.1
IO-360-ES (Cirrus - Sea Level) ^{6, 7}	600 2700	-	7.0 - 9.0 21.0 - 24.0	- 13.8 - 15.5	- 96 - 102	- 16.4 - 17.4
IO-360-ES (Cirrus - 1500 ft press. alt.) ^{6, 7}	600 2700	-	7.0 - 9.0 19.0 - 22.0	- 13.3 - 14.6	- 94 - 98	- 16.0 - 16.7
IO-360-J, JB	600 2600 ⁸	-	7.0 - 9.0 24.0 - 27.0	- 15.8 - 18.2	- 100 - 106	- 17.0 - 18.1
IO-360-K, KB	600 2600	-	7.0 - 9.0 21.0 - 24.0	- 14.3 - 16.3	- 93.5 - 97.5	- 15.9 - 16.6
TSIO-360-A, AB	600 2800	- 32.0	6.5- 7.5 27.2 - 31.2	- 15.8 - 16.7	- 119 - 124	- 20.1 - 21.0
TSIO-360-B, BB	600 2800	- 32.0	6.5 - 7.5 27.2 - 31.2	- 15.8 - 16.7	- 115 - 124	- 20.1 - 21.0
TSIO-360-C, CB	600 2800	- 37.0	6.5 - 7.5 34.0 - 37.0	- 16.7 - 19.3	- 135 - 145	- 23.0 - 24.7
TSIO-360-D, DB	600 2800	- 36.0	6.5 - 7.5 34.0 - 37.0	- 16.7 - 19.3	- 135 - 145	- 23.0 - 24.7
TSIO-360-E, EB, LTSIO-360-E, EB	700 2575	- 40.0	6.25 - 6.75 43.0 - 46.0	- 15.8 - 18.3	- 130 - 140	- 22.1 - 23.8
TSIO-360-F, FB	700 2575	- 41.0	6.25 - 6.75 40.0 - 43.0	- 15.8 - 18.3	- 130 - 140	- 22.1 - 23.8
TSIO-360-G, GB	700 2700	- 40.0	6.25 - 6.75 45.0 - 49.0	- 16.7 - 19.3	- 135 - 145	- 23.0 - 24.7
TSIO-360-H, HB	600 2800	- 34.5	6.5 - 7.5 29.0 - 33.0	- 14.9 - 17.3	- 125 - 135	- 21.3 - 23.0



Table 6-4. Fuel System Adjustment Values

Idle and FULL POWER Fuel Pressures and Flows						
Engine ¹	Prop. RPM	Manifold Absolute Pressure (MAP)	Unmetered Pump PSI ²	Metered Nozzle PSI ³	Fuel (lbs/hr) ⁴	Fuel (gal/hr) ⁴
TSIO-360-JB	600 2800	- 37.0	6.5 - 7.5 34.5 - 37.5	- 16.7 - 19.3	- 134 - 145	- 22.8 - 24.7
TSIO-360-KB, L/TSIO-360-KB	700 2800	- 40.0	6.5 - 7.5 36.0 - 39.0	- 17.7 - 21.2	- 140 - 155	- 23.8 - 26.4
TSIO-360-LB	700 2700	- 40.0	6.25 - 6.75 34.0 - 38.0	- 14.7 - 16.7	- 135 - 145	- 23.0 - 24.7
TSIO-360-MB	700 2700	- 36.0	6.25 - 6.75 28.0 - 32.0	- 13.6 - 15.3	- 125 - 135	- 21.3 - 23.0
L/TSIO-360-RB	700 2600	- 38.0	25 Minimum 35.0 - 45.0	MFG ⁹ -	- 140 - 150	- 23.3 - 25.5
TSIO-360-SB	700 2600	- 39.0	6.25 - 6.75 31 - 36	- 15.1 - 17.8	- 131 - 151	- 22.3 - 25.7
O-470-GCI	600 2600	-	9.0 - 11.0 23.8 - 25.3	- 14.7 - 16.9	- 122 - 129	- 20.8 - 22.0
IO-470-C, G, P, R	600 2600	-	9.0 - 11.0 24.7 - 27.7	- 14.8 - 17.3	- 123 - 130	- 21.0 - 22.1
IO-470-D, E, F, H, L, M, N, S, U	600 2625	-	9.0 - 11.0 25.0 - 28.0	- 15.0 - 17.5	- 124 - 131	- 21.1 - 22.3
IO-470-J, K	600 2600	-	5.5 - 7.0 24.7 - 27.7	- 14.8 - 17.3	- 123 - 130	- 21.0 - 22.1
IO-470-V	600 2625	-	6.5 - 7.5 28.3 - 29.8	- 17.8 - 18.8	- 123.5 - 131	- 21.0 - 22.3
IO-470-VO	600 2625	-	6.5 - 7.5 28.8 - 31.0	- 17.8 - 18.8	- 132 - 137.5	- 22.5 - 23.4
GIO-470-A	450 2400	-	9.0 - 11.0 26.0 - 28.0	- 15.5 - 16.5	- 145 - 155	- 24.7 - 26.4
TSIO-470-B, C, D	600 2600	- 35.0	5.5 - 6.0 28.0 - 30.0	- 15.0 - 17.0	- 145 - 155	- 24.7 - 26.4
IO-520-A, J	600 2700	-	9.0 - 11.0 29.0 - 32.0	- 15.9 - 18.2	- 136 - 146	- 23.2 - 24.9
IO-520-B, BA, BB C, CB	600 2700	-	9.0 - 11.0 28.0 - 31.0	- 14.9 - 17.2	- 136 - 146	- 23.2 - 24.9
IO-520-D, F, K, L	600 2850	-	9.0 - 11.0 30.0 - 33.0	- 17.0 - 19.4	- 143 - 153	- 24.4 - 26.1
IO-520-E	600 2850	-	9.0 - 11.0 29.0 - 32.0	- 16.1 - 18.3	- 143 - 153	- 24.4 - 26.1
IO-520-M, MB	600 2700	-	6.0 - 7.0 29.0 - 32.0	- 16.7 - 19.3	- 136 - 146	- 23.2 - 24.9
IO-520-P, LIO-520-P	600 2500	-	6.0 - 7.0 26.2 - 26.9	- 14.3 - 16.2	- 130 - 140	- 22.1 - 23.9
TSIO-520-AE, LTSIO-520-AE	600 2400	- 32.5	7.5 - 8.5 34.5 - 38.0	- 15.2 - 16.5	- 160 - 165	- 27.3 - 28.1
TSIO-520-AF	600 2700	- 35.5	5.5 - 6.5 35.0 - 39.0	- 18.4 - 19.9	- 180 - 186	- 30.7 - 31.7
TSIO-520-B, BB	600 2700	- 32.0	5.5 - 7.0 29.0 - 32.0	- 16.0 - 17.9	- 165 - 175	- 28.1 - 29.8



Table 6-4. Fuel System Adjustment Values

Idle and FULL POWER Fuel Pressures and Flows						
Engine ¹	Prop. RPM	Manifold Absolute Pressure (MAP)	Unmetered Pump PSI ²	Metered Nozzle PSI ³	Fuel (lbs/hr) ⁴	Fuel (gal/hr) ⁴
TSIO-520-BE	600 2600	- 38.0	5.5 - 7.0 25.0 - 28.0	- 12.7 - 14.1	- 214 - 224	- 36.5 - 38.2
TSIO-520-C, H	600 2700	- 32.5	5.5 - 7.0 29.0 - 32.0	- 15.3 - 17.2	- 160 - 170	- 27.3 - 29.0
TSIO-520-CE	600 2700	- 37.0	5.5 - 6.5 33.0 - 36.0	- 16.2 - 18.0	- 215 - 225	- 36.6 - 38.3
TSIO-520-D, DB	600 2700	- 32.5	5.5 - 7.0 29.0 - 32.0	- 13.3 - 15.1	- 160 - 170	- 27.3 - 29.0
TSIO-520-E, EB	600 2700	- 34.5	5.5 - 6.5 31.0 - 34.0	- 15.6 - 17.7	- 175 - 185	- 29.8 - 31.5
TSIO-520-G	600 2700	- 35.0	5.5 - 6.5 31.0 - 34.0	- 15.8 - 17.6	- 181 - 191	- 30.8 - 32.5
TSIO-520-J, JB	600 2700	- 36.0	5.5 - 6.5 31.0 - 34.0	- 16.9 - 18.7	- 170 - 178	- 29.0 - 30.3
TSIO-520-K, KB	600 2700	- 33.0	5.5 - 7.0 29.0 - 32.0	- 15.1 - 17.4	- 163 - 175	- 27.8 - 29.8
TSIO-520-L, LB	600 2700	- 38.0	25 Minimum 45.0 - 55.0	MFG ¹⁰	- 180 - 190	- 30.7 - 32.4
TSIO-520-M, R	600 2700	- 36.5	5.5 - 6.5 33.0 - 37.0	- 16.9 - 19.9	- 170 - 186	- 29.0 - 31.7
TSIO-520-N, NB	600 2700	- 38.0	5.5 - 6.5 32.0 - 35.0	- 16.9 - 19.9	- 170 - 186	- 28.9 - 31.7
TSIO-520-P	600 2700	- 36.5	5.5 - 6.5 33.0 - 37.0	- 18.4 - 19.9	- 180 - 186	- 30.7 - 31.7
TSIO-520-T	600 2700	- 39.5	5.5 - 6.5 33.0 - 37.0	- 16.3 - 18.1	- 185 - 195	- 31.5 - 33.2
TSIO-520-UB	600 2700	- 36.0	5.5 - 6.5 33.0 - 37.0	- 14.4 - 16.0	- 195 - 205	- 33.2 - 34.9
TSIO-520-VB	600 2700	- 40.5	5.6 - 6.5 36.0 - 39.5	- 16.9 - 18.7	- 200 - 210	- 34.1 - 35.8
TSIO-520-WB	600 2700	- 39.5	25 Minimum 45.0 - 55.0	- MFG ¹¹	- 190 - 200	- 32.4 - 34.1
GTSIO-520-C	525 2400	- 34.5	4.0 - 7.0 30.0 - 33.0	- 16.5 - 17.5	- 215 - 225	- 36.6 - 38.3
GTSIO-520-D, H	467 2267	- 39.5	4.0 - 7.0 30.5 - 35.0	- 15.7 - 17.3	- 250 - 260	- 42.6 - 44.3
GTSIO-520-F, K ¹¹	600 2267	- 44.5	6.75 - 7.25 38.0 - 41.0	- 17.4 - 18.8	- 300 - 310	- 51.1 - 52.8
GTSIO-520-L, N ¹¹ GTSIO-520-M	467 2234	39.0 40.0	4.0 - 7.0 29.5 - 35.0	- 16.4 - 17.9	- 255 - 265	- 43.4 - 45.1
GIO-550-A	600 2267	-	25 Minimum 45 - 55	- MFG ¹¹	- 175 - 185	- 29.8 - 31.5
IO-550-A ⁶	600 2700	- -	8.0 - 10.0 32.0 - 36.0	- 17.7 - 20.0	- 142 - 150	- 24.2 - 25.6
IO-550-B ⁶	600 2700	- -	8.0 - 10.0 29.2 - 36.2	- 16.5 - 18.4	- 146 - 156	- 24.9 - 26.6



Table 6-4. Fuel System Adjustment Values

Idle and FULL POWER Fuel Pressures and Flows						
Engine ¹	Prop. RPM	Manifold Absolute Pressure (MAP)	Unmetered Pump PSI ²	Metered Nozzle PSI ³	Fuel (lbs/hr) ⁴	Fuel (gal/hr) ⁴
IO-550-C ⁶	600 2700	- -	8.0 - 10.0 31.6 - 37.8	- 17.6 - 19.6	- 152 - 160	- 25.9 - 27.3
IO-550-D, E, F, L ⁶	600 2700	- -	8.0 - 10.0 32.0 - 36.0	- 17.2 - 20.0	- 143 - 155	- 24.4 - 26.4
IO-550-G	600 2500	- -	8.0 - 10.0 22.0 - 26.0	- 14.7 - 16.0	- 125 - 130	- 21.3 - 22.1
IO-550-N, P, R	600 2700	- -	8.0 - 10.0 28.0 - 30.0	- 19.0 - 21.3	- 150 - 160	- 25.6 - 27.3
TSIO-550-B	600 2700	- 38.0	7.0 - 9.0 32.0 - 36.0	- 15.3 - 16.9	- 241 - 252	- 41.0 - 42.9
TSIO-550-C	600 2600	- 35.5	7.0 - 9.0 32.0 - 36.0	- 15.3 - 16.9	- 212 - 222	- 36.1 - 37.8
TSIO-550- E	600 2700	- 38.5	7.0 - 9.0 32.0 - 36.0	- 15.3 - 16.9	- 244 - 254	- 41.5 - 43.3
TSIO-550- G	600 2700	- 34.0	7.0 - 9.0 20.5 - 28.5	- 12.4 - 13.6	- 201 - 211	- 35.2 - 35.9
TSIO-550-G MOONEY ¹²	600 2500	- 33.5	7.0-9.0 20.0-23.0	- 10.4-11.6	- 177-180	- 30.0-30.7
TSIO-550- K, N	600 2500	- 37.5	7.0 - 9.0 20.5 - 28.5	- 14.2 - 14.8	- 210 - 220	- 35.8 - 37.5
TSIOL-550-A	600 2600	- 35.0	5.5 - 6.5 32.5 - 35.5	- 17.0 - 19.0	- 170 - 180	- 29.0 - 30.7
TSIOL-550-B	600 2700	- 35.0	6.0 - 8.0 36.0 - 40.0	- 20.0 - 22.5	- 175 - 185	- 29.8 - 31.5
TSIOL-550-C	600 2600	- 39.5	6.0 - 8.0 37.0 - 40.0	- 15.0 - 16.5	- 204 - 216	- 34.8 - 36.8

- The setup procedures contained in this bulletin are only for use on engines that have not been modified from their original configuration as shipped from the factory by Continental Motors. Engines which have been modified by the installation of aftermarket components such as turbo-normalizing systems, turbocharging systems, intercoolers, after-coolers, fuel nozzles, etc., whether by STC or field approval, must use the instructions provided by the STC holder or installer. CM will not accept responsibility or liability for any modified engine set up according to the instructions contained in these instructions.
- FULL POWER unmetered fuel pump pressure limits are provided for reference only. Use metered fuel pressure specifications for adjustments at full power.
- Use for full power, maximum RPM adjustment only. All other parameters for reference only, Footnote 2 applies.
- May be determined using a calibrated in-line flow measuring device. Otherwise use metered fuel pressure specifications. Refer to Aircraft Manufacturer's Maintenance Manual for method of verifying accuracy of fuel flow indicator.
- IO-360DB engine model specifications equipped with altitude compensating fuel pumps; Flight Test (Section 7-2.4.2) required after fuel system adjustment.
- Engine model equipped with altitude compensating fuel pump; Flight Test (Section 7-2.4.2) required after fuel system adjustment.
- This engine installed in Cirrus SR20 aircraft. IO-360-ES engines has been derated by Cirrus from original 210 HP at 2800 RPM to 200 HP at 2700 RPM. Engine data plate reflects original CM data of 210 HP at 2800 RPM. Refer to Cirrus SR20 Maintenance Manual and POH.
- Engine model certified for five minute rated takeoff power at 2800 RPM. Max. continuous power is 2600 rpm
- Refer to the aircraft manufacturer's instructions for adjustment procedures.
- Refer to the aircraft manufacturer's instructions for adjustment procedures.
- Refer to the aircraft manufacturer's instructions for adjustment procedures.
- TSIO-550-G installed in Mooney aircraft has been rated to a power level that is less than the approved Type Certificate Data Sheet. Refer to the Mooney Aircraft Maintenance Manual for setup instructions.



6-4.7.1.1. Static RPM Compensation

NOTE: Engine driven fuel pump pressures vary with engine RPM. Rated FULL POWER RPM may not be achieved during ground run-up. Use the Fuel Flow Compensation Table to adjust the metered pressures if FULL POWER RPM cannot be achieved. Fuel Pressure compensation for the IO-240-A and B engine models is provided in Table 6-6.

Table 6-5. Static Ground Setup Compensation Table
Metered pressure vs. RPM @ 70° F fuel temperature

Static Engine RPM	Correction Factor	Corrected Metered Pressure	
		Minimum	Maximum
Rated RPM	1		
-20	.991		
-40	.982		
-60	.973		
-80	.964		
-100	.955		
-120	.946		

Procedure

To determine the appropriate correction factor:

Subtract the maximum static RPM from the maximum rated RPM.

Locate the number closest to the difference between rated RPM and maximum observed static RPM.

Multiply the correction factor adjacent to the maximum static RPM by the rated metered pressure to determine the corrected metered pressure. If the maximum static engine RPM = 2640, (-60 RPM); Metered Fuel Pressure Range (in Table 6-4) is 14.9 - 17.2, use the *Correction Factor of 0.973*

Example:	IO-520-BB rated RPM	2700
	Maximum static RPM	<u>2640</u>
	Difference	60

The corrected minimum metered pressure limit @ 2640 RPM is $14.9 \times 0.973 = 14.5$

The corrected maximum metered pressure limit @ 2640 RPM is $17.2 \times 0.973 = 16.7$

The formula is: *Metered Fuel Pressure Limits x Correction Factor = Corrected Metered Pressure Limits @ Static Engine RPM*



**Table 6-6. IO-240-A, B With Standard Fuel Pump
Full Throttle Static RPM Metered Fuel Pressure Specifications**

Full Throttle Static Engine RPM	Nominal Metered Fuel Pressure (allowed variation ± 0.3)
2400	11.2
2350	10.8
2300	10.5
2250	10.2
2200	9.9
2150	9.6
2100	9.4
2050	9.1
2000	8.8
1950	8.6
1900	8.3
1850	8.1
1800	7.8



6-4.7.2. Maintenance Preflight Inspection

Prior to starting the engine, perform a preflight inspection of the engine, propeller, nacelle, and aircraft. This inspection must be performed prior to the first flight after engine installation, inspection, troubleshooting, maintenance, or overhaul work to determine if the aircraft and engine are in an airworthy condition. Do not release a malfunctioning engine for flight.

WARNING

Operation of a malfunctioning engine can result in additional damage to the engine, possible bodily injury or death.

Procedure

1. Turn the Master Power Switch and the Ignition Switch to the OFF position.
2. Remove engine cowling according to the aircraft manufacturer's instructions.
3. Check the throttle, mixture control, propeller (if equipped), carburetor heat (if equipped) and alternate air supply controls for freedom of movement and full range of travel.

WARNING

Ensure the propeller arc is clear of personnel and obstructions before starting the engine.

4. Drain the aircraft fuel sumps according to the aircraft manufacturer's instructions.
5. Remove, clean, inspect, and reinstall the aircraft fuel screens according to the aircraft manufacturer's instructions.
6. Inspect the aircraft vapor return system (if equipped) for proper operation in accordance with aircraft manufacturer's instructions.
7. Purge the aircraft fuel system.
 - a. Disconnect the fuel supply hose from the engine driven fuel pump and terminate the fuel supply hose in a large, clean container suitable for waste fuel.
 - b. Operate the aircraft fuel boost pump (or gravity drain) to allow a minimum of one gallon (3.8L) of fuel to flow into the container. Inspect the fuel for contaminants; locate and correct the source of contaminated fuel, if detected.
 - c. Reconnect the fuel supply line and torque to Appendix B specifications.

WARNING

Use of inaccurate gauges will result in incorrect fuel system adjustment, probable accelerated engine wear and possible engine damage.

8. Verify the fuel system components are properly configured (part numbers conform to type design and parts are installed properly) according to the engine illustrated parts catalog.



Engine Inspection and Service

9. Ensure the fuel manifold valve vent (if equipped) and fuel pump drain lines (if equipped) are properly installed, open and free of obstructions according to the installation instructions.
10. Inspect the engine control rod ends for wear, proper installation and security in accordance with aircraft manufacturer's instructions.
11. Lubricate engine control rod ends and fuel system moving parts using the approved lubricants listed in Section 3-1 and the aircraft manufacturers instructions.

WARNING

The engine is certified for operation with the aviation fuels specified on the Type Certificate Data Sheet (TCDS). If the minimum grade required is not available, use the next higher grade. Use of lower octane rated fuel or jet fuel will result in damage to, or destruction of, an engine the first time high power is applied. If the aircraft is inadvertently serviced with the wrong grade of fuel, or jet fuel, drain the fuel system completely and service the fuel tanks in accordance with the aircraft manufacturer's instructions and perform a "Contaminated Fuel System Inspection" inspection according to instructions in Section 6-5.6.

12. Service the aircraft fuel system according to the aircraft manufacturer's instructions.
13. Check the engine oil level. Service the oil sump as required with the oil grade specified in Section 3-1.
14. Verify the engine crankcase breather is secure with no breather air flow restrictions.
15. If the engine is newly installed or being returned to service after long-term storage, pre-oil the engine according to the instructions in Section 5-2.9.
16. Verify the induction air filter is clean and securely in place. Replace the air filter with a clean one if it is dirty; tighten the filter if it is loose.
17. Visually inspect the engine, propeller hub area, and nacelle for evidence of fuel and engine oil leaks. Correct any discrepancies.
18. Visually inspect the engine and nacelle for debris, loose, missing or broken lines, hoses, fittings, clamps and connections. Inspect for restrictions to cooling airflow; remove any debris.
19. Verify all baffles and baffle seals are installed, correctly positioned, and serviceable.
20. If the engine has been exposed to temperatures below 20°F (-7 C) for more than 2 hours, preheat the engine according to "Engine Preheating" instructions in Section 7-4.1.1. If the engine has been exposed to an ambient temperature between 20° to 40°F (-7° to 4° C), refer to the "Cold Weather Starting Without Preheating" instructions in Section 7-4.1.1.3.



6-4.7.3. Oil Pump Operational Check

1. Perform a Maintenance Preflight Inspection according to Section 6-4.7.2.
2. Perform a normal “Engine Start” according to instructions in Section 7-3.2 and “Ground Run-up” according to Section 7-3.3 to allow the engine to warm to normal operating temperatures.
3. Oil Pressure Check
RESULT: Verify oil pressure is between **30** and **60** psi (**80 psi** for TSIO-360-E, EB, F, FB, GB, KB, LB, MB, RB & SB) which at cruise power RPM. If necessary, adjust according to the “Oil Pressure Adjustment” instructions in Section 6-4.10.1. If no oil pressure is noted, shut down the engine immediately and investigate the cause.
4. If no further checks are required, proceed to “Engine Shutdown” in Section 6-4.7.6.

6-4.7.4. Fuel System Operational Check

CAUTION: Fuel system operational check instructions in this section and the adjustments in Section 6-4.10.2 apply only to Continental Motors (CM) continuous flow fuel injection systems. For engines equipped with carburetors or servo controlled fuel systems, refer to aircraft and/or equipment manufacturer’s instructions.

A fuel system operational check is required after replacement of fuel injection system components, such as the fuel pump, fuel manifold valve, or fuel injectors. The fuel system setup is a critical component of proper engine operation.

Follow the test equipment setup instructions in Section 6-4.7.4.1. When the test equipment is set up properly, proceed with the “Fuel System Operational Checkout Procedure” in Section 6-4.7.4.3.

NOTE: Fuel system adjustments are interactive. Once begun, perform the entire procedure for proper fuel injection system operation.

Required Test Equipment

- Portable Tachometer
- Model 20 ATM-C Porta Test Unit (Section 2-1)

OR

- Calibrated pressure gauges (Section 2-1)

NOTE: Pressure gauges must be accurate within +/- 1%. The calibration period should not exceed one year.

- A calibrated 0-60 psi gauge, graduated in 1 psi increments, to measure unmetereed pressure.
- *On naturally aspirated engines*, a calibrated 0-30 psi gauge graduated in 0.2 psi increments, to measure metered pressure, or
- *On turbocharged engines*, a calibrated differential pressure gauge, 0-30 psid maximum, graduated in 0.2 psi increments.
- Two Part No. MS51523-B4 swivel tees, used to insert gauges in line with fuel lines, for metered and unmetereed pressure references.



- Hoses of sufficient length to allow personnel and equipment to perform the test at a safe distance from the propeller arc and blast area.
- A digital hand-held tachometer, capable of verifying aircraft tachometer accuracy prior to fuel system adjustment.

6-4.7.4.1. Fuel System Operational Checkout Setup Instructions

Important Setup Notes

CAUTION: For L/TSIO-360 and TSIO-520 engine models equipped with a fixed (ground adjustable) exhaust bypass, verify the wastegate is adjusted according to the aircraft manufacturer's instructions. Failure to do so can result in an improperly adjusted fuel system and possible engine damage.

1. Test gauge readings must be taken with the gauges held at the same height above the ground as the fuel system component being measured.
2. Engine driven fuel pump output pressures vary with engine RPM. During ground operation, full power RPM may not be obtained. Use the “Static RPM Compensation” instructions found in Section 6-4.7.1.1 to correct the specified metered pressures if full power RPM cannot be achieved.
3. *On turbocharged engines*, ensure manifold pressure is adjusted according to the aircraft manufacturer’s instructions. Engine driven fuel pumps installed on turbocharged engines are referenced to turbocharger compressor discharge pressure (upper deck pressure) to achieve full power fuel pump pressure.
4. Turbocharged engines equipped with fuel pressure regulators must indicate a full power metered pressure and fuel flow five (5) percent higher than the maximum specified limit **when the regulator is disconnected**. This is required to ensure adequate part-throttle fuel flow.

WARNING

Failure to properly support and stabilize component fittings can result in fitting and/or component damage and loss of system pressure.

Procedure

1. Perform a Maintenance Preflight Inspection according to Section 6-4.7.2.
2. Loosen and remove the unmetered fuel supply hose from either the fuel pump outlet fitting, the fuel control unit inlet fitting, or the throttle body/metering unit inlet tee (whichever is most accessible). Some engine models have a fuel pressure connection fitting in the fuel control inlet screen that may be utilized for unmetered pressure gauge attachment.

NOTE: Some installations may require multiple fittings to adapt the metered and unmetered test equipment to the fuel injection system. Connect the unmetered fuel supply hose to the straight end of the tee connector.



3. For engine models with integral throttle body/metering units (see Figure 6-37), remove and set aside the cap fitting (P/N 639494) from the inlet tee. This cap will be reinstalled after setup is complete.
4. Connect a tee fitting (P/N MS51523-B4) directly to the fuel connection loosened in step 2 (see Figure 6-3 through Figure 6-6, as applicable). Torque the tee fitting to the value specified in Appendix B.

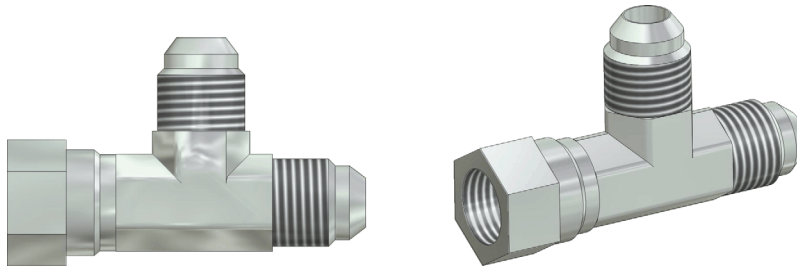

Figure 6-1. Part No. MS51523-B4 Swivel Tee

5. Attach the unmetered fuel supply hose to the straight end of the tee fitting (P/N MS51523-B4) and torque to the value specified in Appendix B.
6. Connect the unmetered test hose from the Porta-Test Unit to the tee fitting and torque to the value specified in Appendix B.
GAUGE METHOD: If using the 0 to 60 PSI gauge, connect the gauge to the tee fitting using a length of hose which will provide proper clearance from the engine cowling and propeller arc. Torque connections to the value specified in Appendix B.
7. Loosen and remove the metered fuel supply hose from the manifold valve inlet fitting.
8. Install and torque the second tee fitting directly to the fuel manifold valve inlet fitting.
9. Attach the metered fuel supply hose to the straight end of the second tee fitting and torque to the value specified in Appendix B. On certain models there is an optional capped fitting on the manifold valve in lieu of second tee fitting.
10. Connect the metered pressure test hose from the Porta-Test Unit to the second tee fitting and torque to the value specified in Appendix B.
GAUGE METHOD: If using the 0 to 30 PSI gauge, connect to the swivel end of the tee fitting using a hose long enough to provide proper clearance from the engine cowling and propeller arc.
11. Torque all connections to the value specified in Appendix B.
12. *On turbocharged engine models*; connect the Porta-Test manifold pressure hose and the upper deck pressure hose to the engine following the instructions provided with the Porta-Test unit.
GAUGE METHOD: If using the 0 to 30 PSID differential gauge pressure fitting, connect to the metered pressure tee fitting using a hose of sufficient length to provide clearance from the aircraft and propeller arc. Connect an equal length of hose to the “suction” side of the gauge and connect the other end to a location to



Engine Inspection and Service

- reference turbocharger compressor discharge (upper deck) pressure (see Figure 6-5 and Figure 6-6)
13. Turbocharged engine models (incorporating a fuel pressure regulator) must have the regulator deactivated during the initial fuel system adjustment. (see Figure 6-44).
 - a. To deactivate the fuel pressure regulator, loosen and remove the fuel line or hose from the “center” (outlet) port fitting at the pressure regulator.
 - b. Install a cap on the “center” (outlet) port fitting.
 - c. Install a plug in the removed line (or hose).
 - d. Torque the cap and plug to the values specified in Appendix B.
 - e. Perform a pressurized leak test on the connections prior to proceeding with fuel system adjustments.
 14. Position the throttle control to the FULL OPEN position and the mixture control to FULL RICH. Operate the aircraft boost pump in accordance with the aircraft manufacturer’s instructions. Bleed the air from the test unit and hoses according to the Porta-Test unit instructions.

GAUGE METHOD: If using the alternative calibrated test gauges, loosen the test connections at each gauge to bleed the lines of any air. Hold the gauge at or slightly above the height of the fuel system component during the bleeding operation. Operate the boost pump only long enough to allow purging of air from the installed test equipment. Verify that all fuel lines, hoses and fittings are securely torqued and that no fuel leaks exist before proceeding. Ensure test hoses have been routed clear of the exhaust system and are securely supported over their entire length to avoid inaccurate gauge readings.

WARNING

Drain all fuel from the induction system prior to attempting engine start. Failure to comply may result in hydraulic lock and subsequent engine failure.

15. Install the engine cowling or cooling shroud during ground operation.
16. Proceed to Section 6-4.7.4.3.

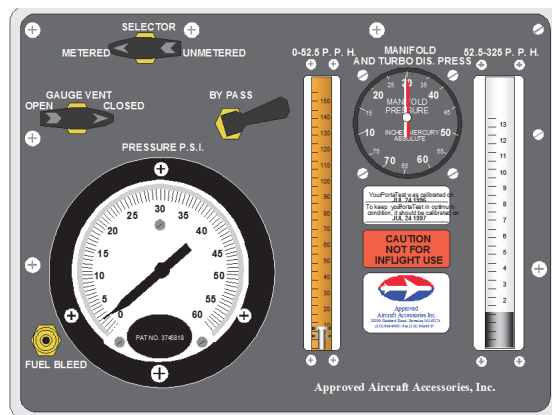

Figure 6-2. Model 20 ATM-C Porta-Test



6-4.7.4.2. Test Equipment Connection Schematics

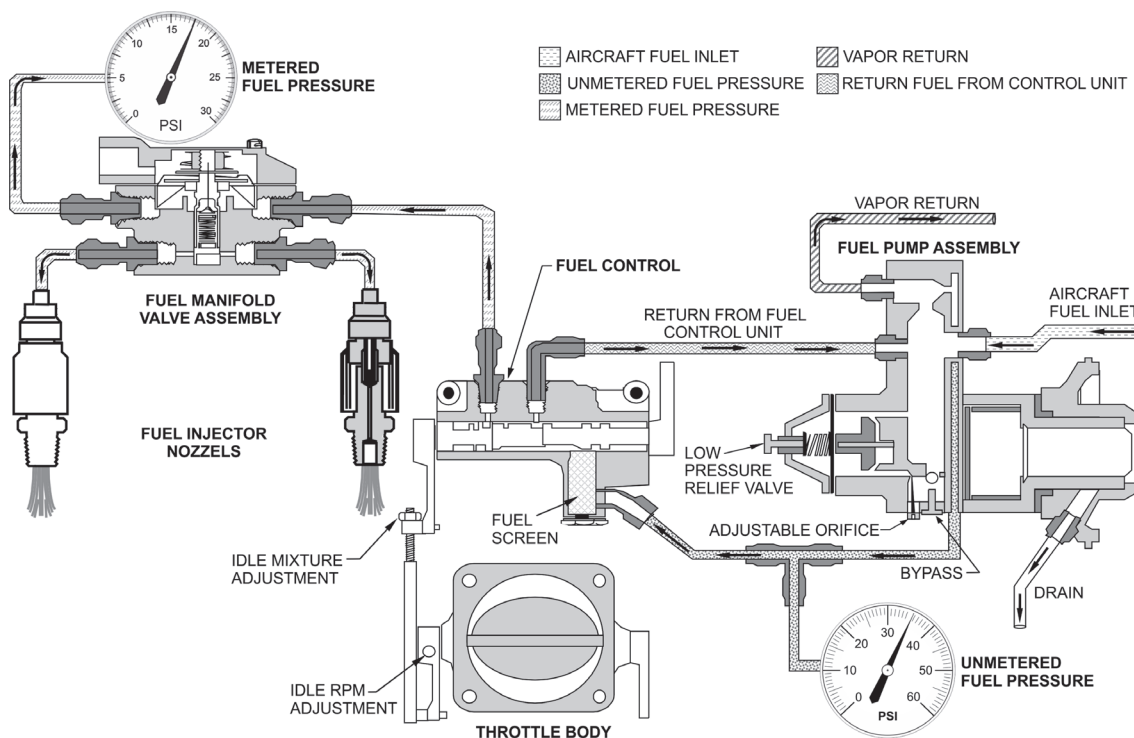

Figure 6-3. Typical Naturally Aspirated Fuel System Schematic (with Fuel Control Unit)

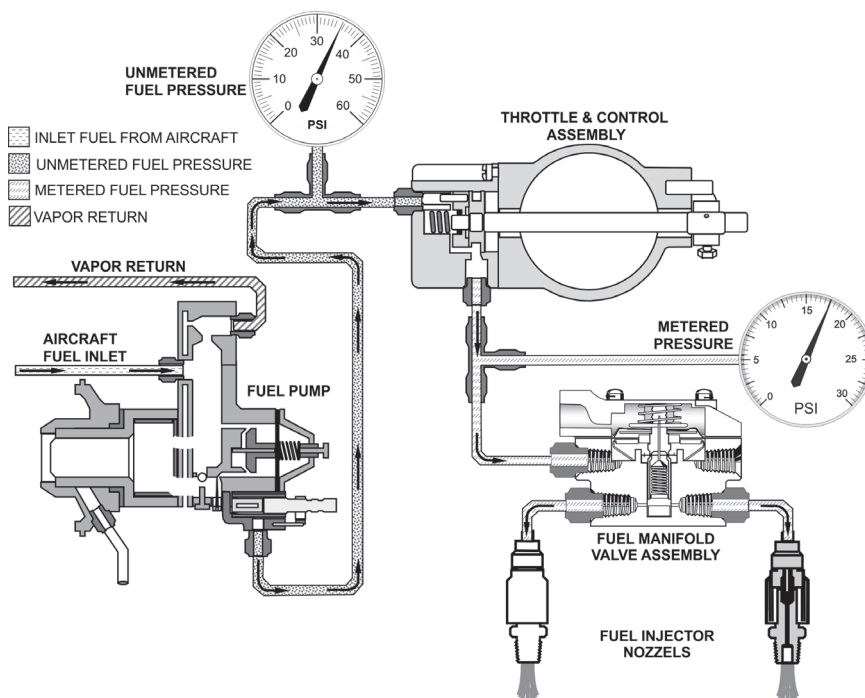

Figure 6-4. Typical Naturally Aspirated Fuel System Schematic (Fuel Pump with Integral Mixture Control)

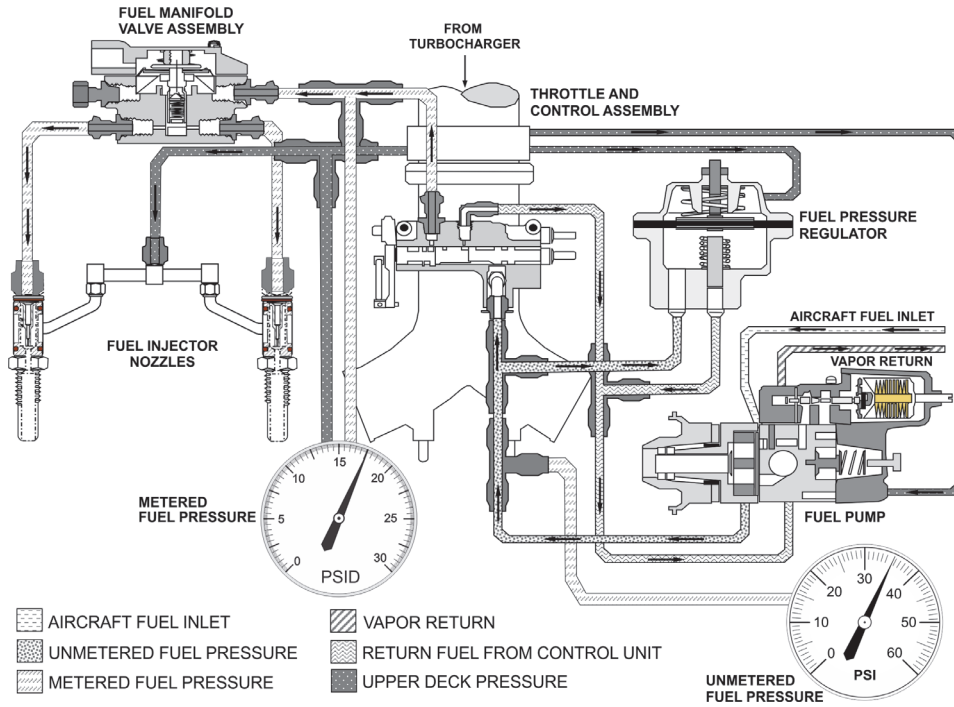

Figure 6-5. Typical Turbocharged Fuel System Schematic (with Fuel Control Unit and Fuel Regulator)

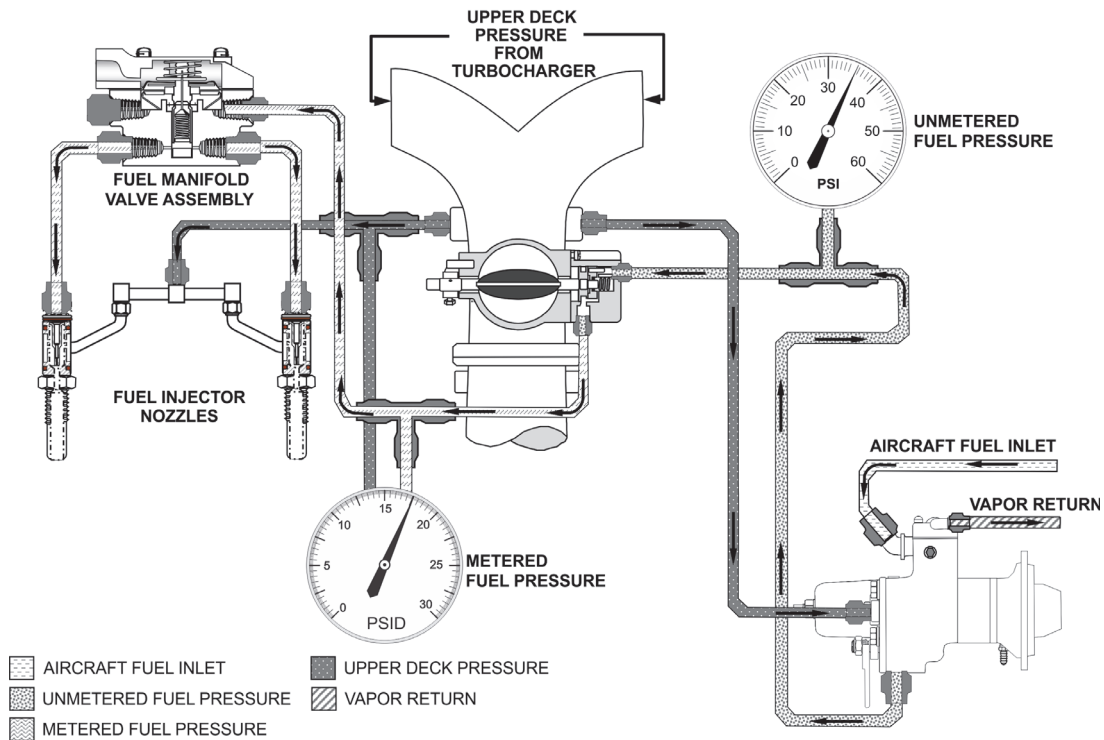

Figure 6-6. Typical Turbocharged Fuel System Schematic (Fuel Pump with Integral Mixture Control)



6-4.7.4.3. Fuel System Operational Checkout Procedure

Procedure

1. Set the aircraft brakes and block the aircraft main landing gear tires.
2. Verify the accuracy of the tachometer, manifold pressure gauge, and fuel flow gauges prior to making any adjustments; replace faulty gauges.
3. Locate the IDLE speed stop screw (Figure 6-37 or Figure 6-39) on the throttle body and turn it counter-clockwise two complete turns. During the operational check, IDLE RPM will be controlled manually using the cockpit throttle control.

WARNING

Ensure the propeller area is clear before starting the engine.

4. Fuel Selector Valve ON
5. Mixture Control FULL RICH
6. Boost Pump (if equipped) AFM/POH
7. Perform a normal “Engine Start” according to instructions in Section 7-3.2 and “Ground Run-up” according to Section 7-3.3 to allow the engine to warm to normal operating temperatures.

NOTE: A puff of white smoke from a new or rebuilt engine, or an engine returned from storage is normal. The source of the smoke is the remaining preservation oil in the burning off in the combustion chamber. The smoke should dissipate quickly; if smoke persists, shut down the engine and investigate the cause.

CAUTION: Operating the engine without oil pressure will result in engine malfunction or failure.

8. Throttle..... 600-1000 RPM (One minute)
RESULT: Operate the engine for one minute, gradually increasing the speed to 1000 RPM in 3 minutes.

9. Oil Temperature Check

NOTE: Allow the engine oil to reach normal operating temperature (100°F (38°C) for turbocharged engines or 75°F (24°C) for naturally aspirated engines) before proceeding to the next step.

10. Boost Pump..... OFF
11. Mixture Control FULL RICH
12. Throttle..... Set to IDLE RPM (Table 6-4)

13. Unmetered Fuel Pressure Gauge..... Check
RESULT: Unmetered fuel pressure is within the range specified in Section 6-4.7.1. Maintain engine speed until CHT is 250°F to 350°F (121°C to 177°C) and engine oil temperature is 160°-180°F. Record the unmetered fuel pressure, regardless of setting. If the unmetered fuel pressure is not within the limits specified in Section 6-4.7.1, adjust the fuel pressure according to the instructions in Section 6-4.10.2.



WARNING

Do not operate the engine at speeds above 1700 RPM until the oil temperature reaches minimum takeoff temperature (100°F (38°C) for turbocharged engines or 75°F (24°C) for naturally aspirated engines) and oil pressure is within the normal operating range. Operating at speeds above 1700 RPM before reaching the minimum oil temperature may result in engine malfunction or engine failure.

NOTE: To eliminate rough idling after mixture rise check, set engine RPM to 1500-1800 RPM for 15 seconds before returning to IDLE RPM.

- 14. Mixture Control Retard *slowly* to IDLE CUT-OFF
 RESULT: Monitor engine RPM as mixture is leaned; stop leaning when maximum RPM is achieved and record engine RPM. IDLE mixture rise should be 25 to 50 RPM (50-75 RPM for **IO-240-B** only) before beginning to drop toward zero. If mixture rise is less than 25 RPM (50 for **IO-240-B**), the mixture is too lean. If the mixture rise is more than 50 RPM (75 for **IO-240-B**), the mixture is too rich. Adjust the idle mixture rise according to instructions in Section 6-4.10.2.

NOTE: The IDLE MIXTURE RISE is the difference (or RISE) between the IDLE RPM at FULL RICH and the maximum achievable IDLE RPM.

- 15. Mixture Control FULL RICH
- 16. Propeller Governor WIDE OPEN
- 17. Throttle..... WIDE OPEN
 RESULT: Check the engine RPM with a portable tachometer. Record the engine speed on the checklist. If the engine does not reach the rated, full power RPM, calculate the corrected metered fuel pressure (Table 6-5 or Table 6-6).

NOTE: If no Manifold Pressure is provided for the engine model in Table 6-4, skip step 18.

- 18. Manifold Pressure Check
 RESULT: Manifold pressure should equal the value specified for the engine model in Section 6-4.7.1. If manifold pressure is not within the specified limits, adjust the Wastegate Controller according to instructions in Section 6-4.10.3.
- 19. Metered Fuel Pressure Gauge Check
 RESULT: The full power, metered fuel pressure should equal the value in Section 6-4.7.1, with Table 6-5 or Table 6-6 correction factor, if applicable. Record the metered fuel pressure, regardless of setting. If the full power, metered fuel pressure is not within the specified limits, adjust the metered fuel pressure according to Section 6-4.10.2.

- 20. Throttle..... Position to desired IDLE RPM
 RESULT: adjust IDLE RPM according to instructions in Section 6-4.10.2.
- 21. Perform a “Flight Check”, if required, according to the instructions in Section 7-2.4.2.
- 22. If no further checks are required, proceed to “Engine Shutdown” instructions in Section 6-4.7.6.



6-4.7.5. Magneto RPM Drop Check

WARNING

Absence of RPM drop during magneto check may be an indication of a faulty ignition circuit (Hot Magneto). Should the propeller be turned by hand (as in during preflight), the engine could inadvertently start and cause personal injury or death. Flight is prohibited until the condition is corrected.

CAUTION: When operating on single ignition, some RPM drop and slight engine roughness as each magneto is switched off should be noted. Excessive (greater than 150 RPM) RPM drop may indicate a faulty magneto or fouled spark plugs.

NOTE: If the engine runs roughly after single magneto operation, increase engine speed to 2200 RPM in the BOTH position and lean the mixture control until the RPM peaks for ten seconds before returning to the full rich position to clear the spark plugs and smooth operation before returning to single magneto operation.

Procedure

1. Start the engine according to the “Engine Start” instructions in Section 7-3.2.
RESULT: No defects noted. Allow the engine oil to warm to normal (100°F (38°C) for turbocharged engines or 75°F (24°C) operating temperature.

CAUTION: Avoid prolonged single magneto operation to preclude spark plug fouling.

NOTE: In the instructions below, the term “Magneto Switch” applies to the method the aircraft manufacturer uses to control the magnetos. Some manufacturers use a wafer switch to control the starter with four additional positions for magneto control, labeled OFF, L, R and BOTH. Toggle switches may be used to accomplish the same action. Adjust instructions according to the available aircraft controls.

2. Throttle..... 1700 RPM
3. Magneto Switch R
RESULT: RPM drop does not exceed 150 RPM; record Left Magneto channel drop result. Maximum allowable RPM drop spread between magneto channels is 50 RPM.
4. Magneto Switch BOTH
5. Magneto Switch L
RESULT: RPM drop does not exceed 150 RPM; record Right Magneto channel drop result. Maximum allowable RPM spread between magneto channels is 50 RPM.
6. Magneto Switch BOTH
7. Throttle..... Reduce to IDLE
8. If no further checks are required, proceed to “Engine Shutdown” on page 32.



6-4.7.6. Engine Shutdown

Procedure

1. Perform a normal engine shutdown according to the “Engine Shutdown” instructions in Section 7-3.4.
2. Remove installed test equipment.
 - a. Disconnect the metered fuel pressure test hose from the aircraft fittings.
 - b. Disconnect the unmetered fuel pressure test hose from between the fuel pump and the fuel control assembly.
 - c. Remove any fittings added to adapt the plumbing to the test equipment.
3. Reconnect and torque the fuel system hoses to Appendix B specifications.
 - a. Connect the unmetered pressure hose between the fuel pump and the fuel control assembly.

CAUTION: Use only P/N 639494 cap on the tee fitting. Installation of a pipe thread cap on the flared fitting may damage the fitting.

- b. Install the protective caps (P/N 639494) (or airframe-installed fitting to cockpit metered pressure gauge) on the fuel manifold valve (metered pressure) or throttle body inlet tee (metered pressure) fittings, if equipped.
4. Leak Check
 - a. Master Power Switch ON
 - b. Mixture..... FULL RICH
 - c. Boost Pump Switch (if equipped)..... ON
 - d. Throttle..... WIDE OPEN
 - e. Check for leaks in the following areas and correct any discrepancies before releasing the engine for flight:
 - 1) Induction System
 - 2) Exhaust System
 - 3) Fuel System
 - 4) Lubrication System
 - f. Boost Pump..... OFF
 - g. Throttle..... IDLE
 - h. Mixture..... IDLE CUT-OFF
 - i. Master Power Switch OFF



6-4.8. Engine Oil Servicing

The engine lubrication system provides either pressure or splash oil to areas of the engine subject to frictional loading. A certain amount of oil consumption is normal if the plane is flown on a regular basis. However, if oil consumption exceeds the Brake Specific Oil Consumption rate in the primary ICA (**Ref: Section 1-1.1**) or there is an abrupt change in the rate of oil consumption, determine the cause and correct it before further flight.

WARNING

Do not fly the aircraft if oil consumption is abnormal or is suspect; investigate for oil leakage. If no oil leakage is noted, perform the “Cylinder Inspections” in Section 6-4.11.

6-4.8.1. Check and Replenish Engine Oil Level

Maintain the oil sump capacity at the specified level. To check the oil level or add oil, perform the following procedure:

WARNING

Check the oil level before each flight and maintain the engine oil at the specified level. Engine operation with less than the specified capacity will cause engine malfunction or failure.

Petroleum based aviation engine oil is flammable. Follow fire hazard precautions. Store oil in a well-ventilated area away from heat or ignition sources.

NOTE: Ensure the aircraft is on level grade and the engine has been shut down for at least five minutes for accurate reading on oil gauge rod.

Procedure

1. Withdraw the oil gauge rod (dipstick) (See Figure 6-7 through Figure 6-22 for engine oil servicing points).
2. Wipe the oil from the oil gauge rod with a clean, lint-free cloth. Avoid getting any lint or debris in the oil sump.
3. Insert the cleaned oil gauge rod back into the oil sump and withdraw the rod again.
4. Verify the oil on the rod touches, but does not pass the oil fill line on the rod.

NOTE: Oil sump capacities differ by engine models. Refer to the “Engine Specifications” in the primary ICA (**Ref: Section 1-1.1**).

CAUTION: When adding oil, completely remove the protective seal from the oil container to prevent the seal from falling into the oil fill port. Prevent any debris from falling into the oil fill port.

5. If more oil is required, add a sufficient quantity of oil meeting the specifications in Section 3-1 to reach the fill line on the oil gauge rod.

NOTE: If oil is spilled on the engine or nacelle during servicing, clean the spilled oil immediately and dispose of oily rags and absorbent materials according to local environmental regulations.



6. Install and lock the oil gauge rod in the fill tube after servicing the engine oil.

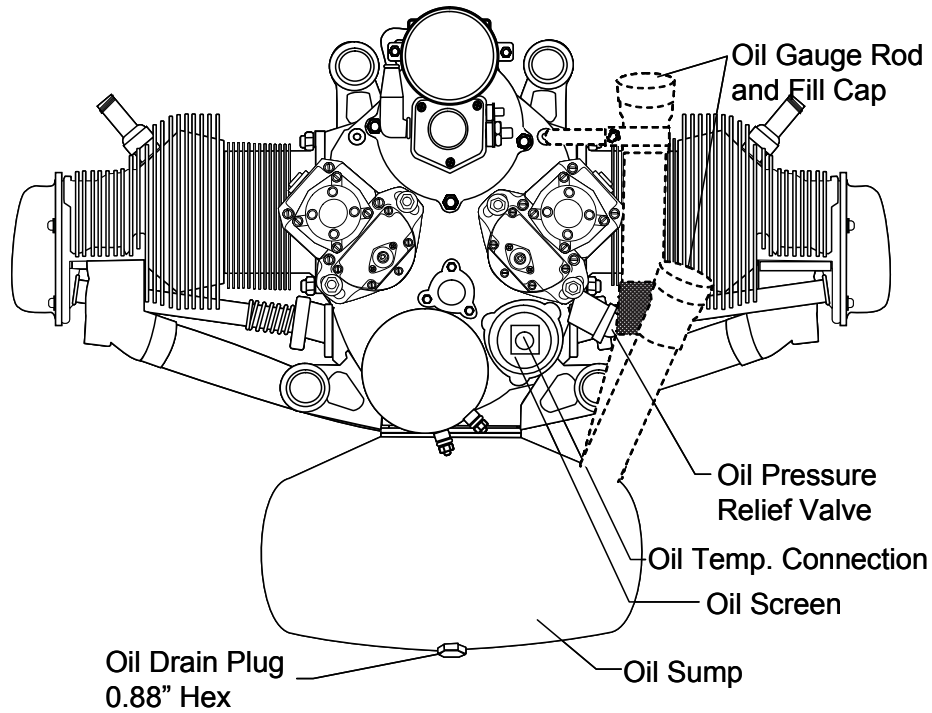

Figure 6-7. C-75, C-85, C-90 & O-200-A Oil Servicing Points (typical)

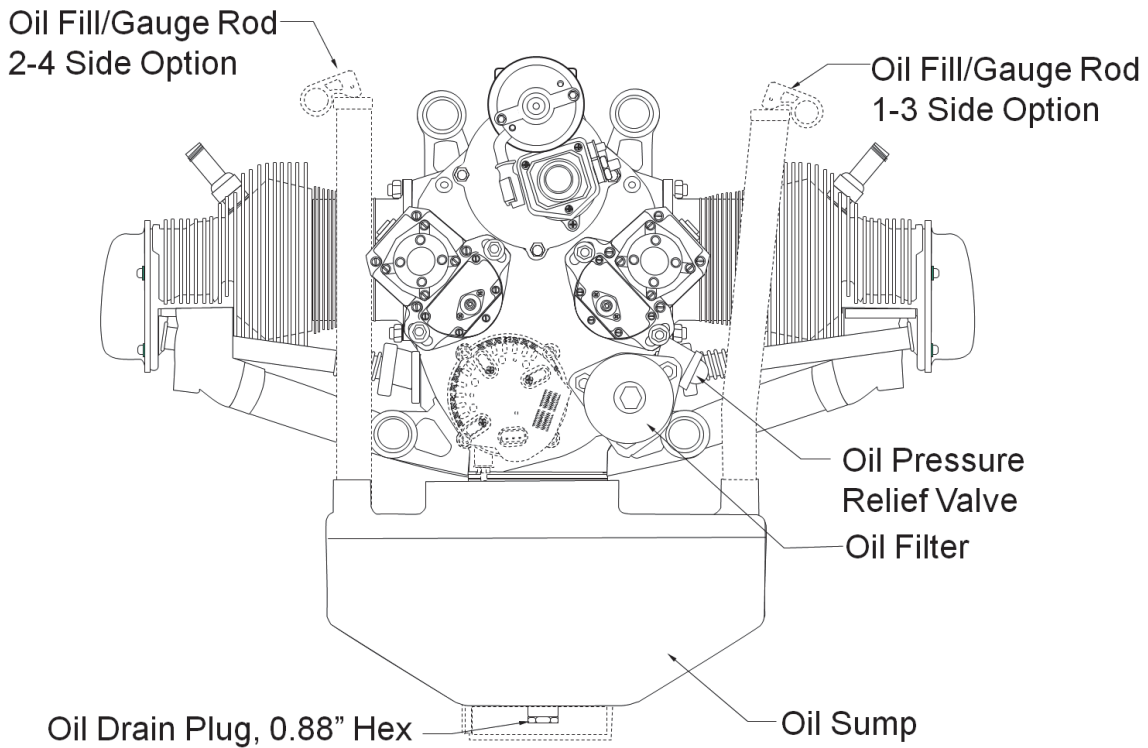

Figure 6-8. O-200-D & X Oil Servicing Points

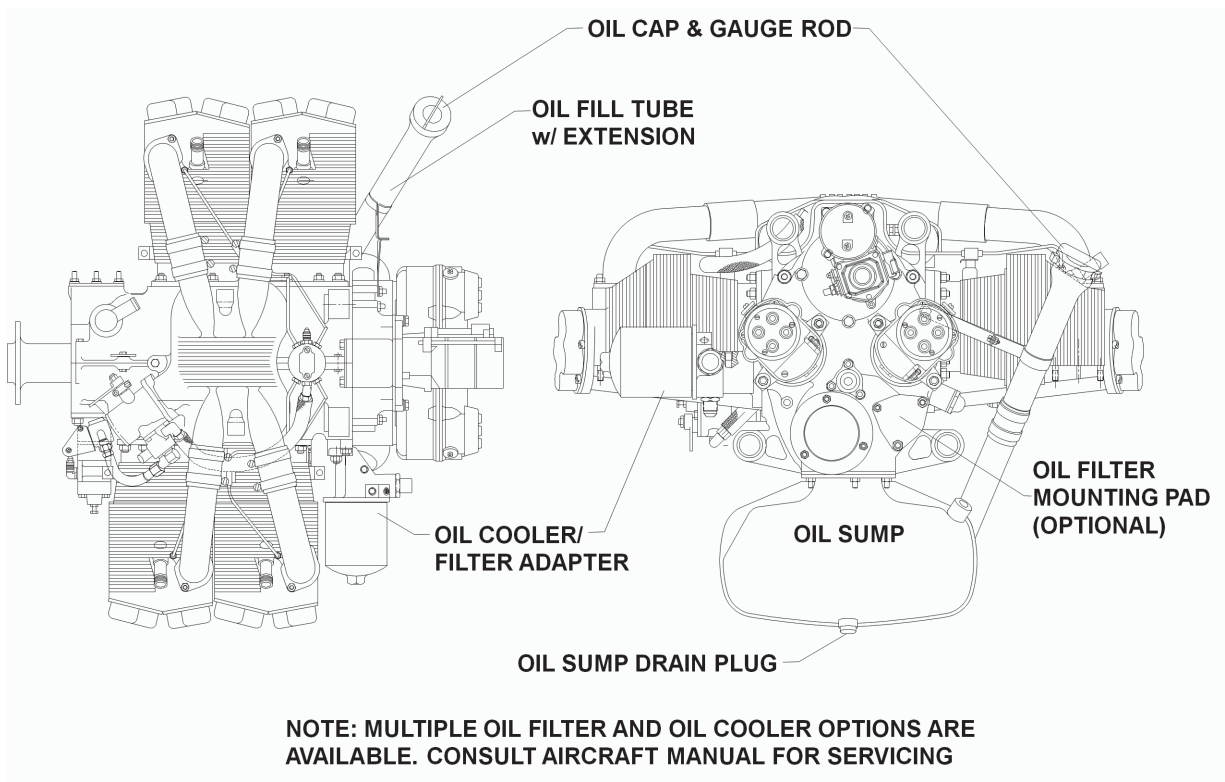

Figure 6-9. IO-240-B Oil Servicing Points (typical)

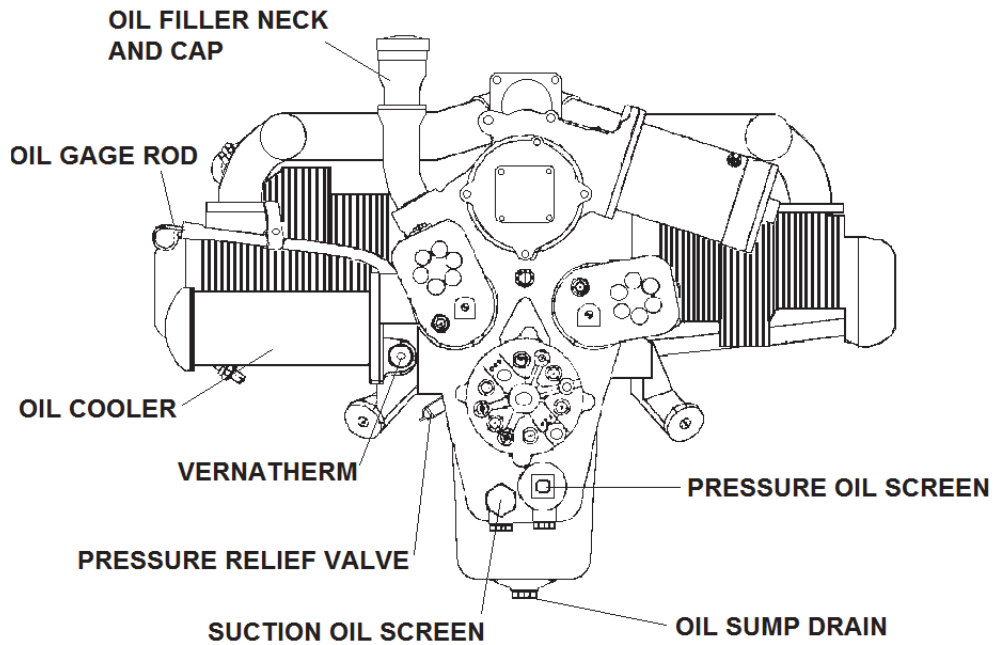
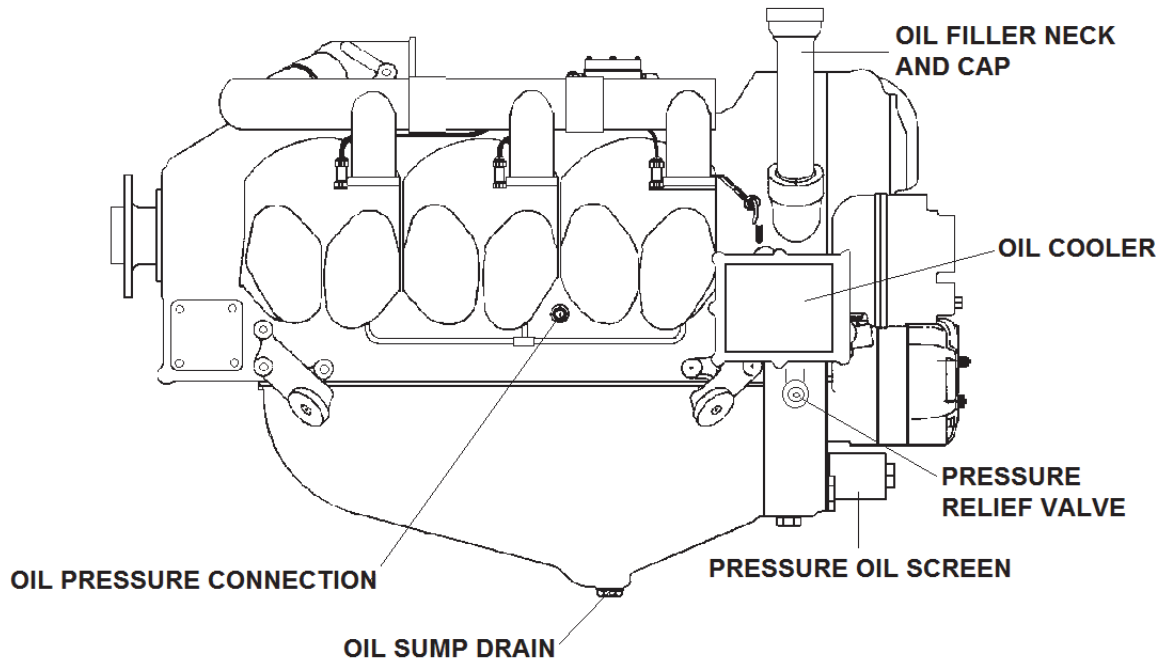

Figure 6-10. IO-360 Oil Servicing Points (typical)

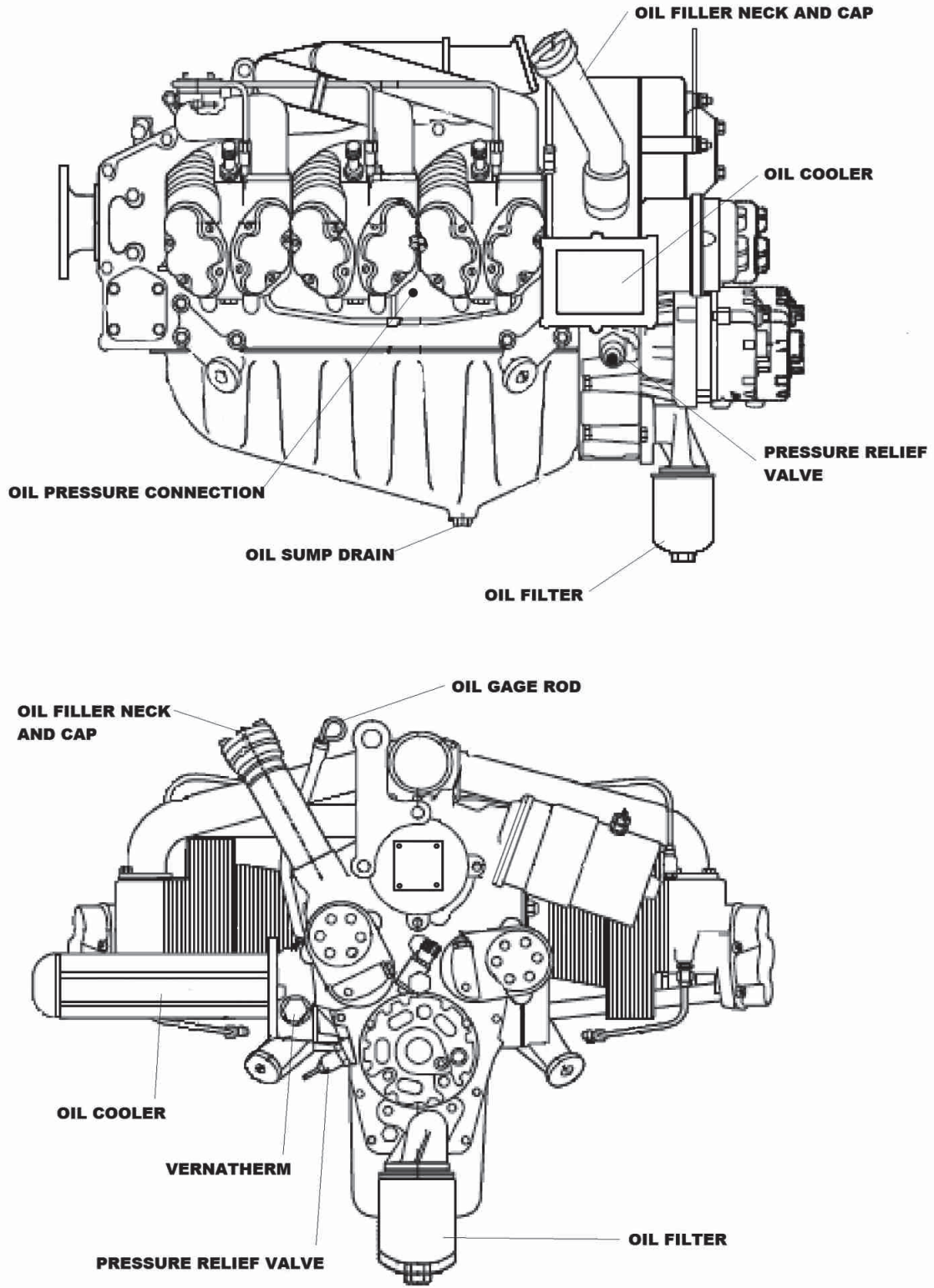

Figure 6-11. IO-360-AF/ES Oil Servicing Points

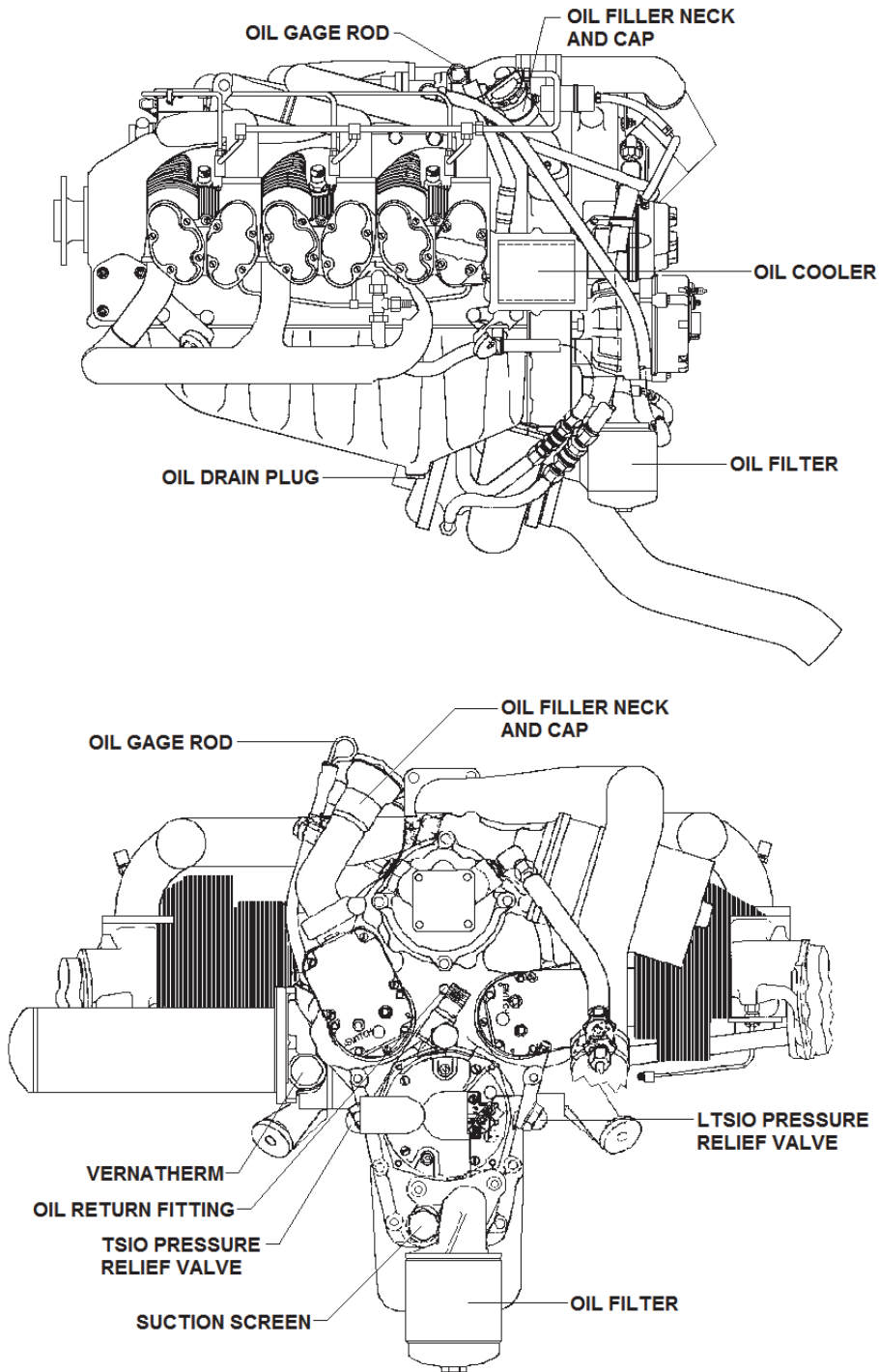

Figure 6-12. TSIO-360 Oil Servicing Points (typical)

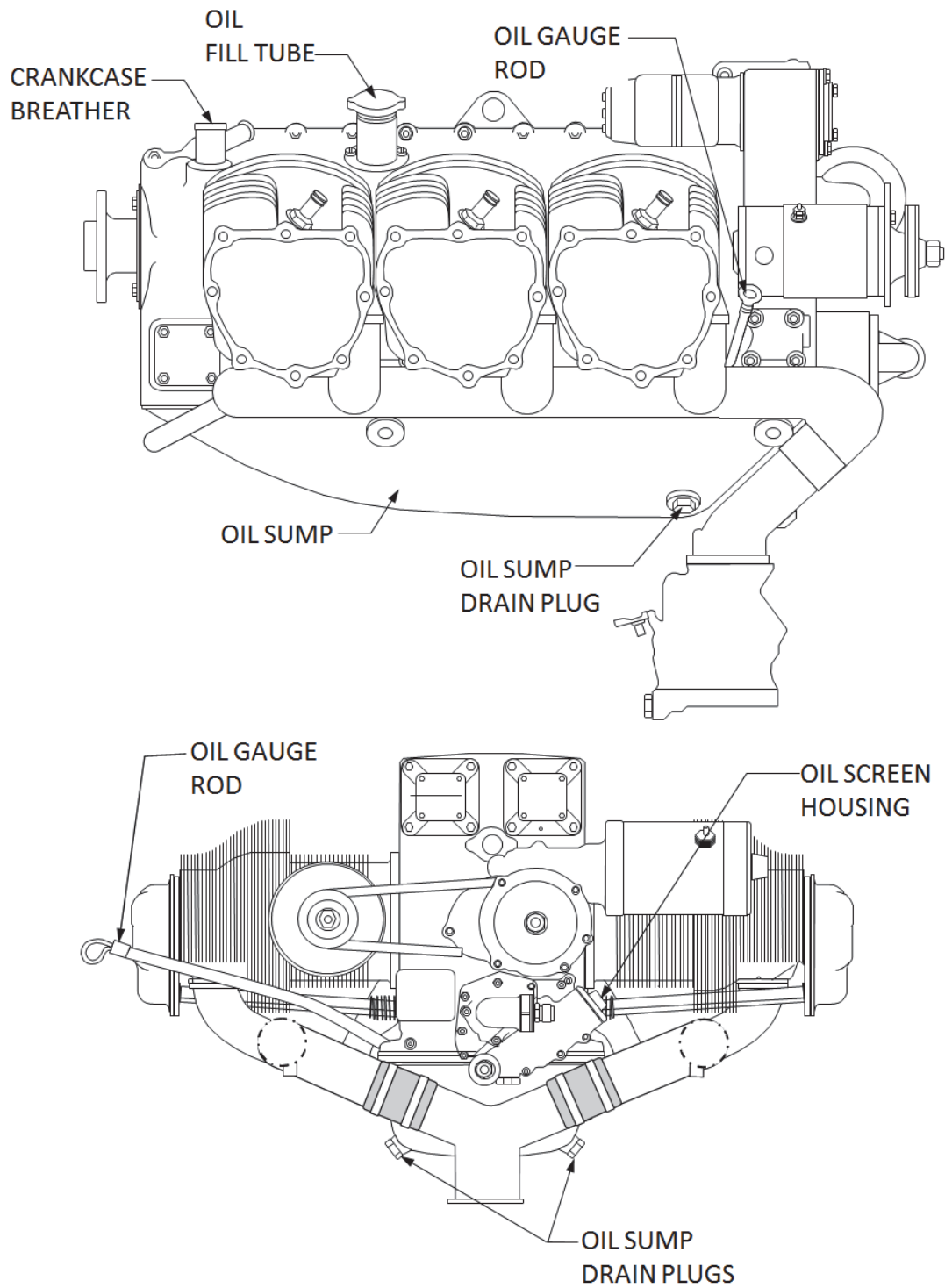

Figure 6-13. O-470 Oil Servicing Points (typical)

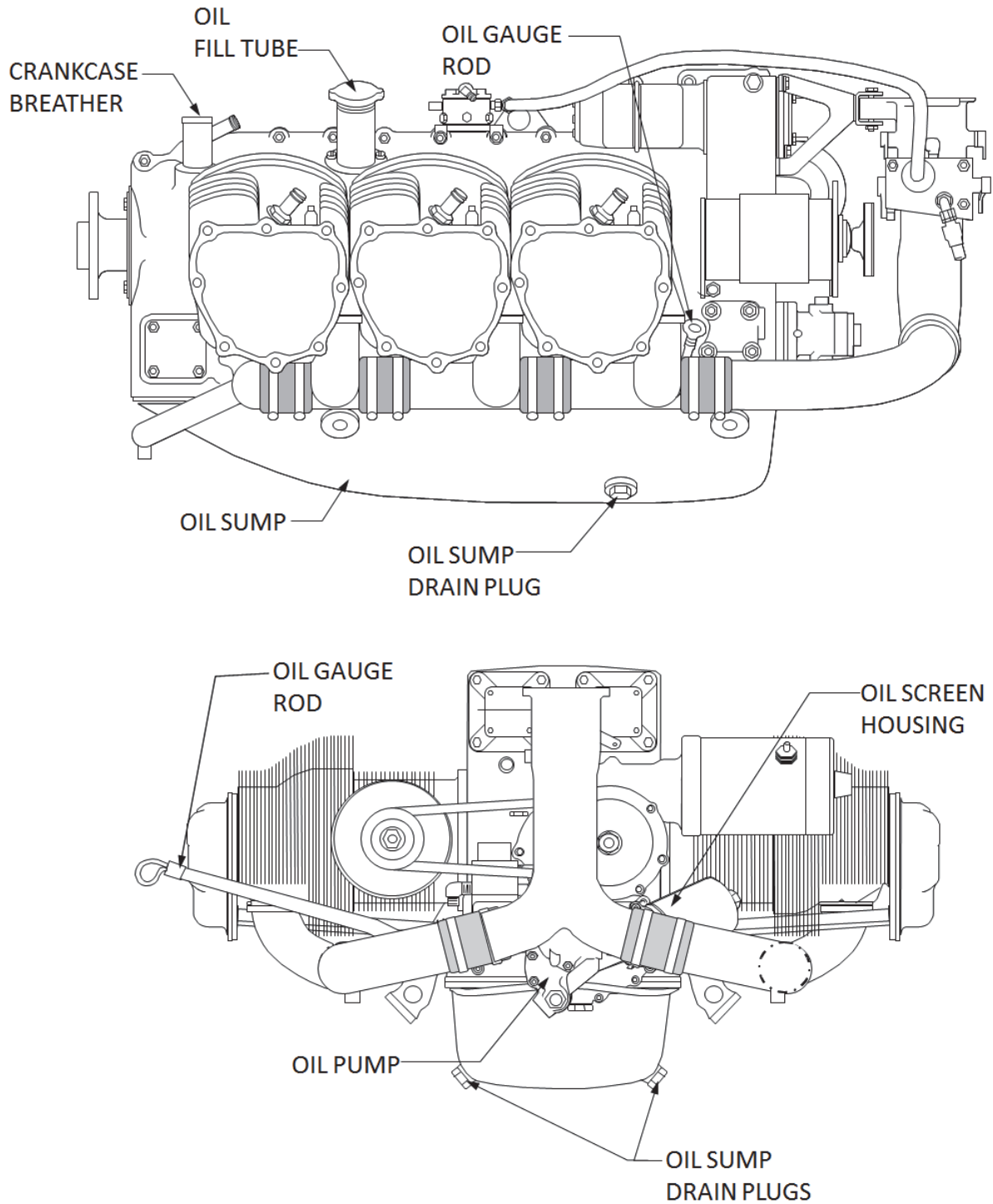

Figure 6-14. IO-470/TSIO-470 Oil Servicing Points (typical)
(typical for IO-520/TSIO-520 engine models with Sandcast Crankcase)

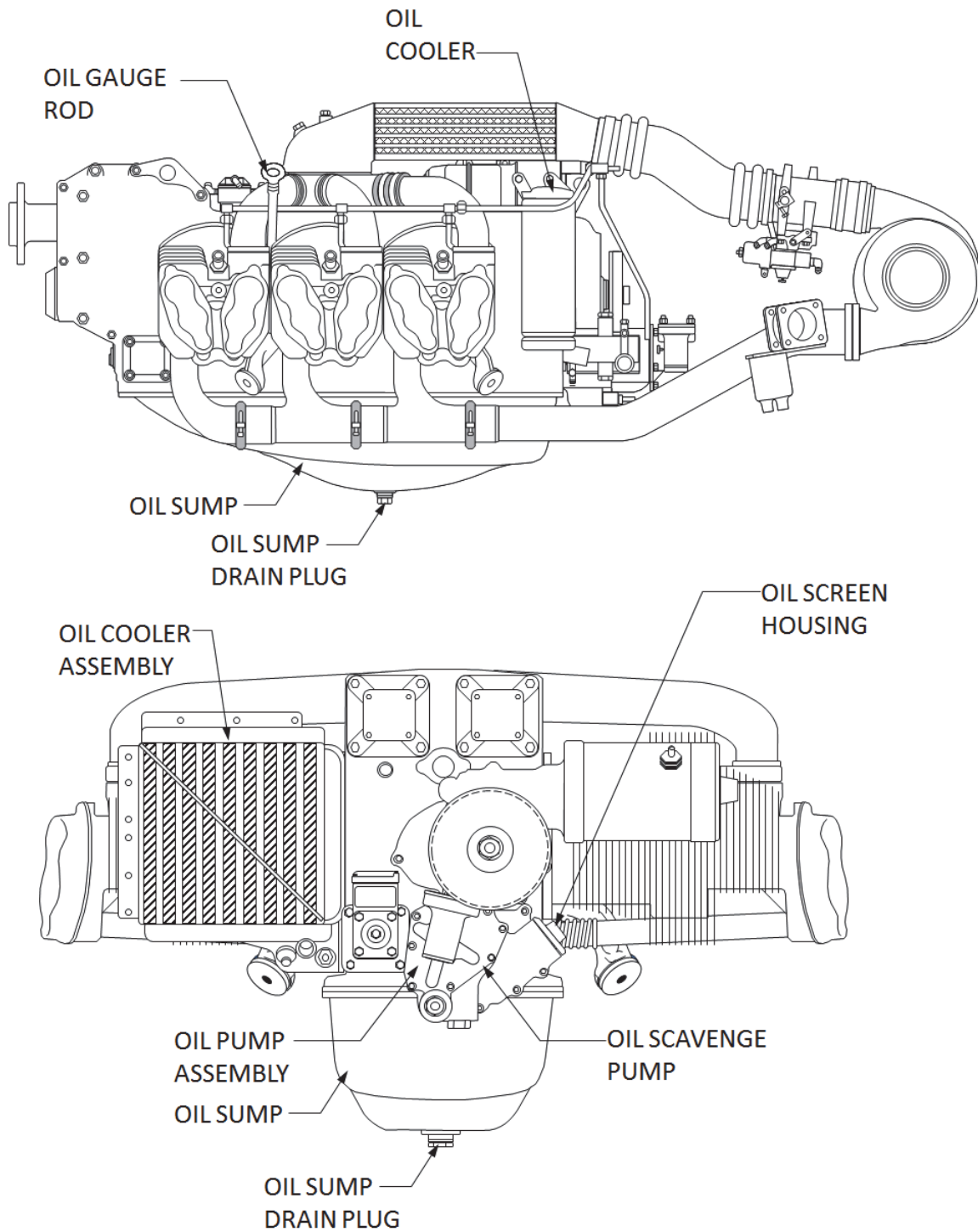

Figure 6-15. GTSIO-520 Oil Servicing Points (typical)

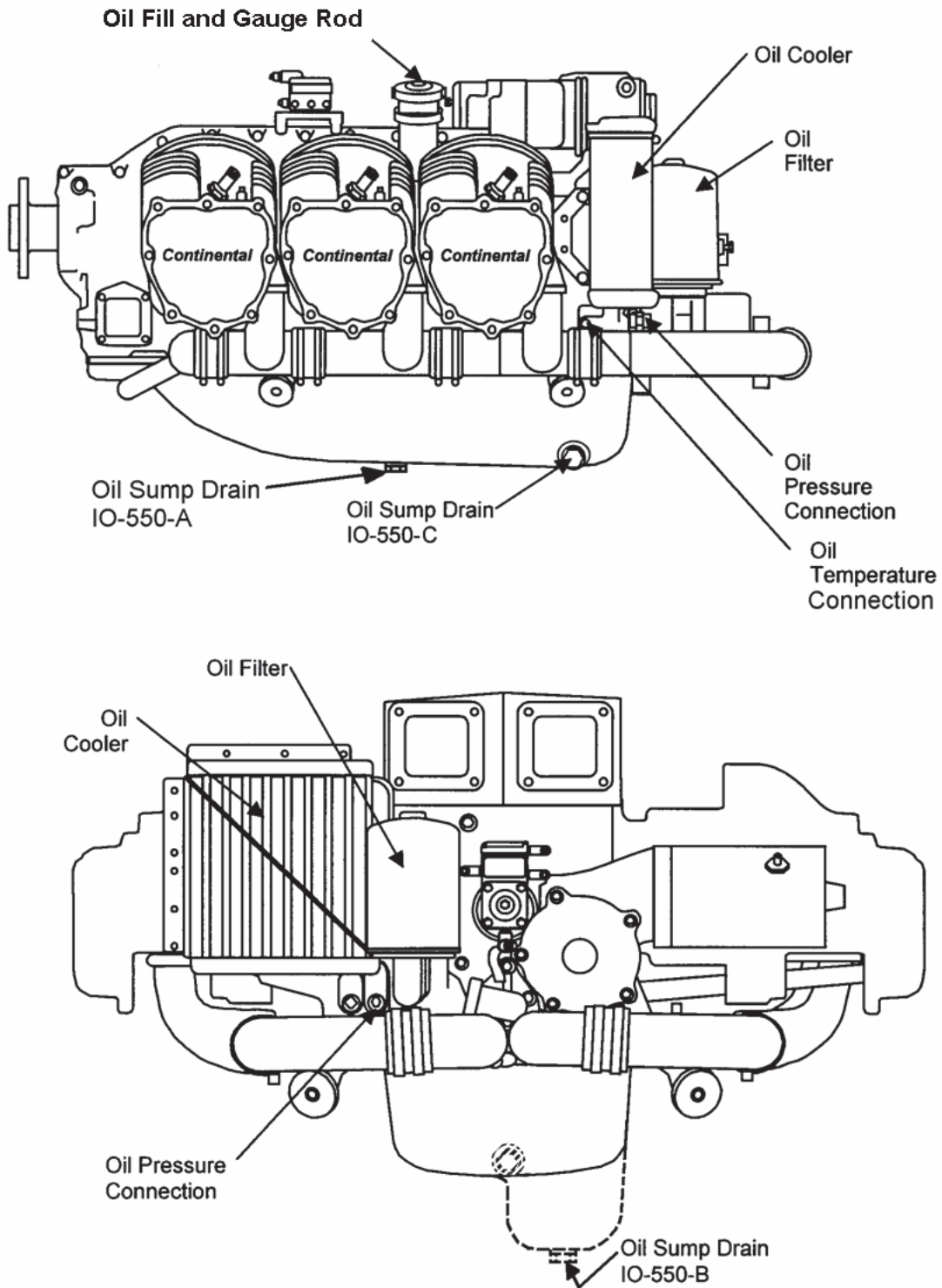

Figure 6-16. IO-550-A, B & C Oil Servicing Points

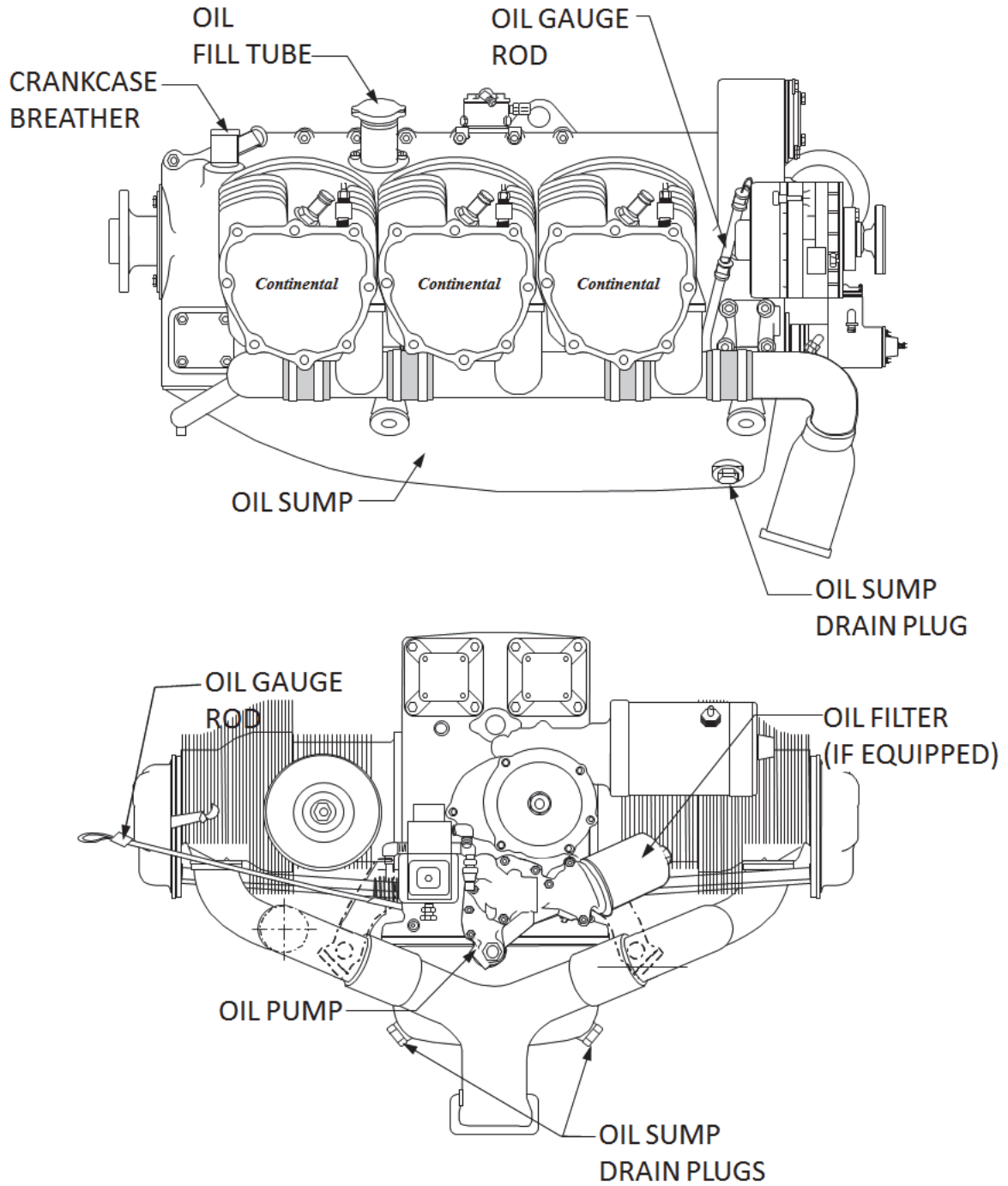

Figure 6-17. IO-550-D, E & F Oil Servicing Points

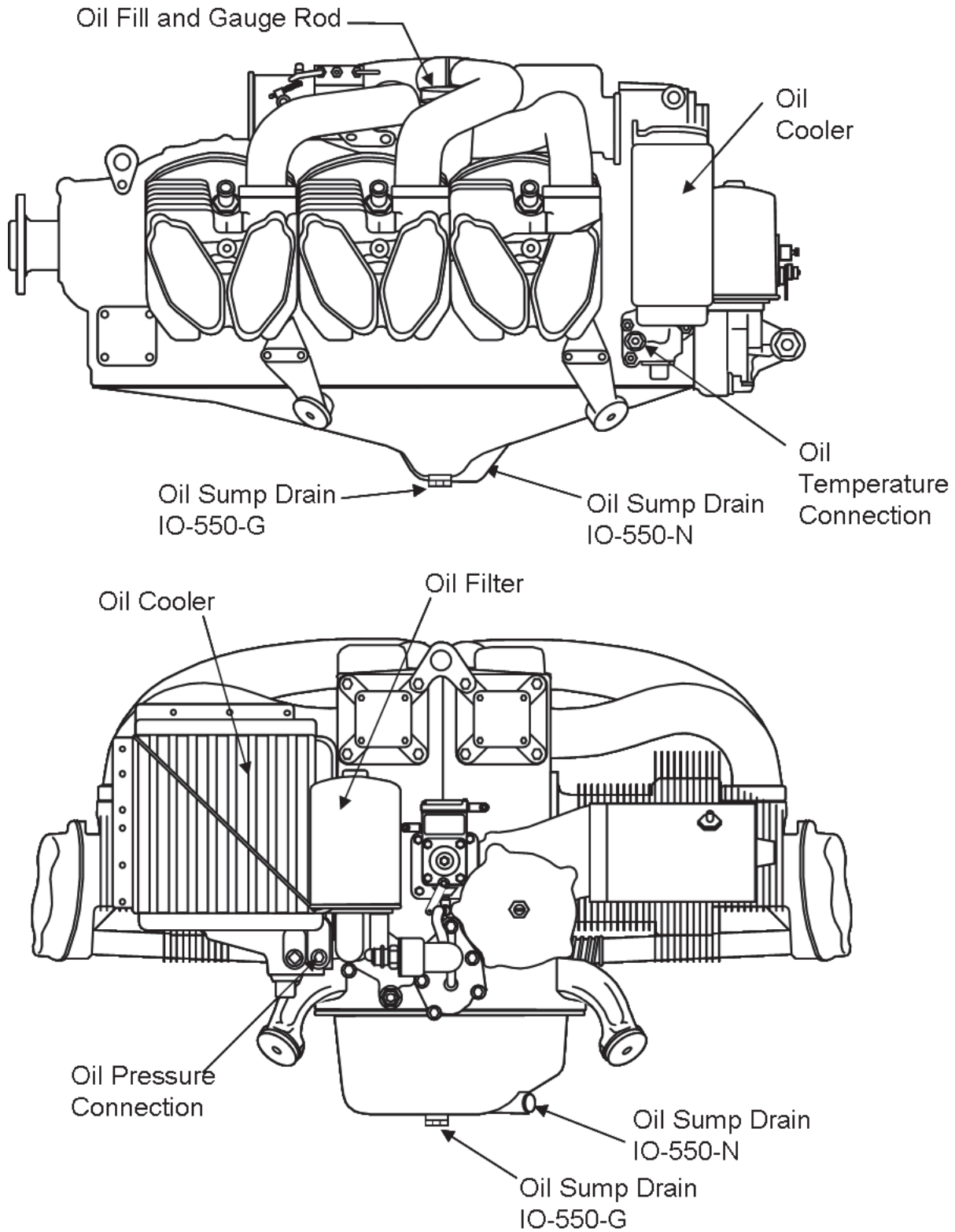

Figure 6-18. IO-550-G & N Oil Servicing Points

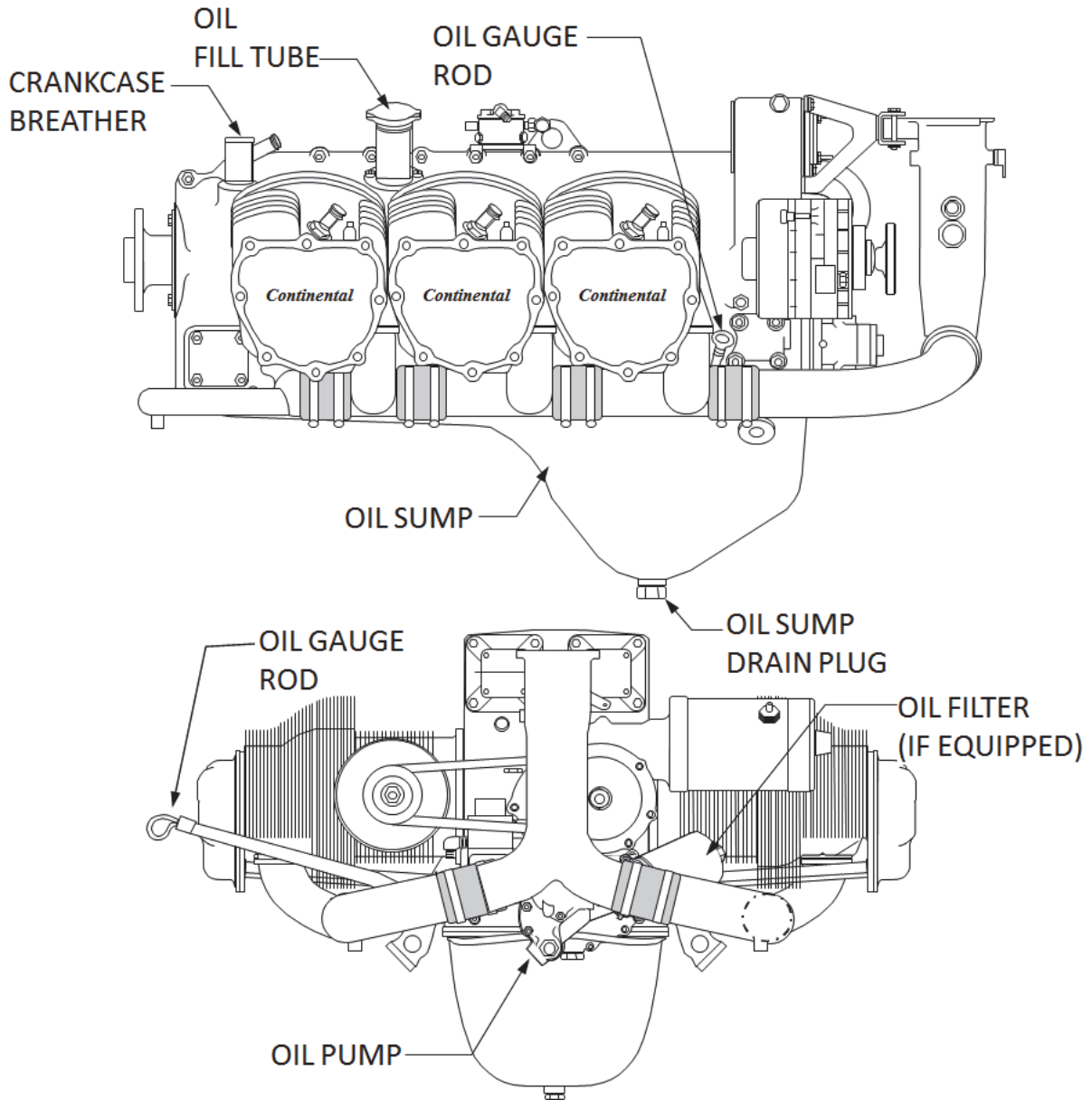

Figure 6-19. IO-550-L Oil Servicing Points

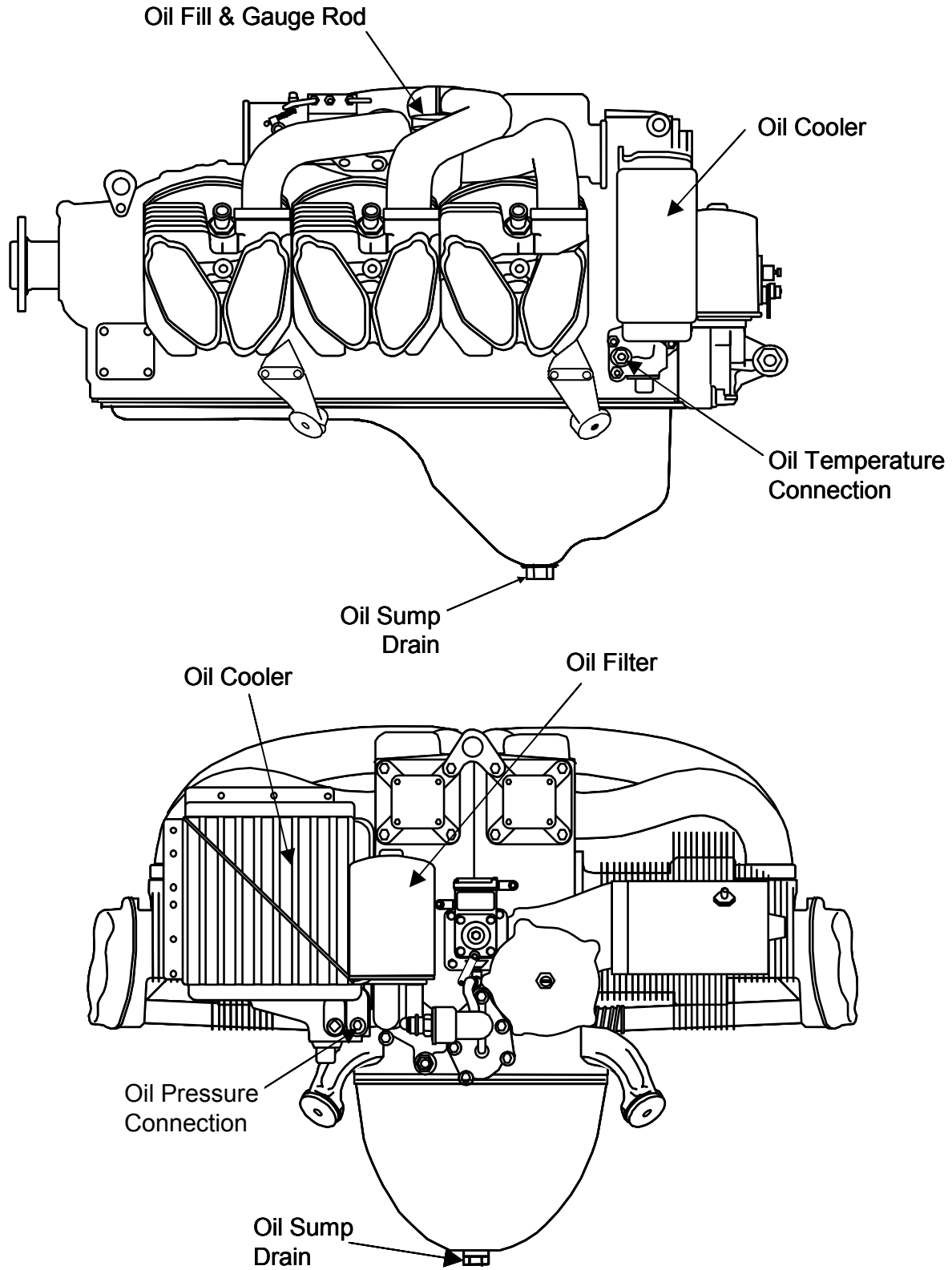

Figure 6-20. IO-550-P Oil Servicing Points

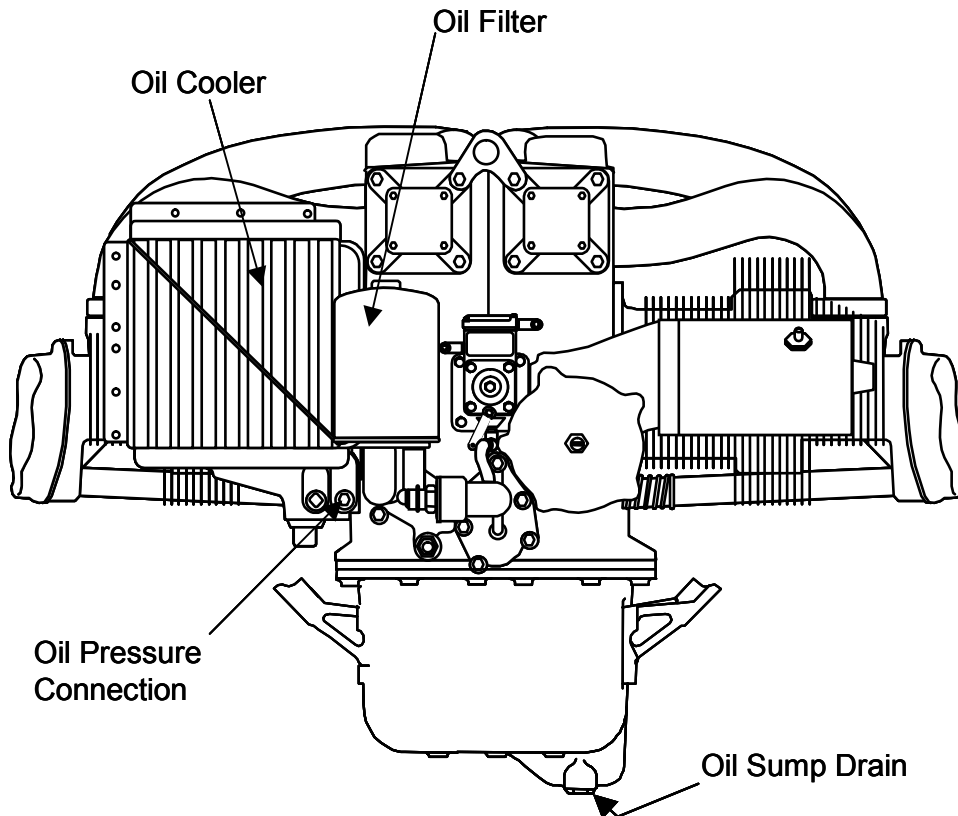
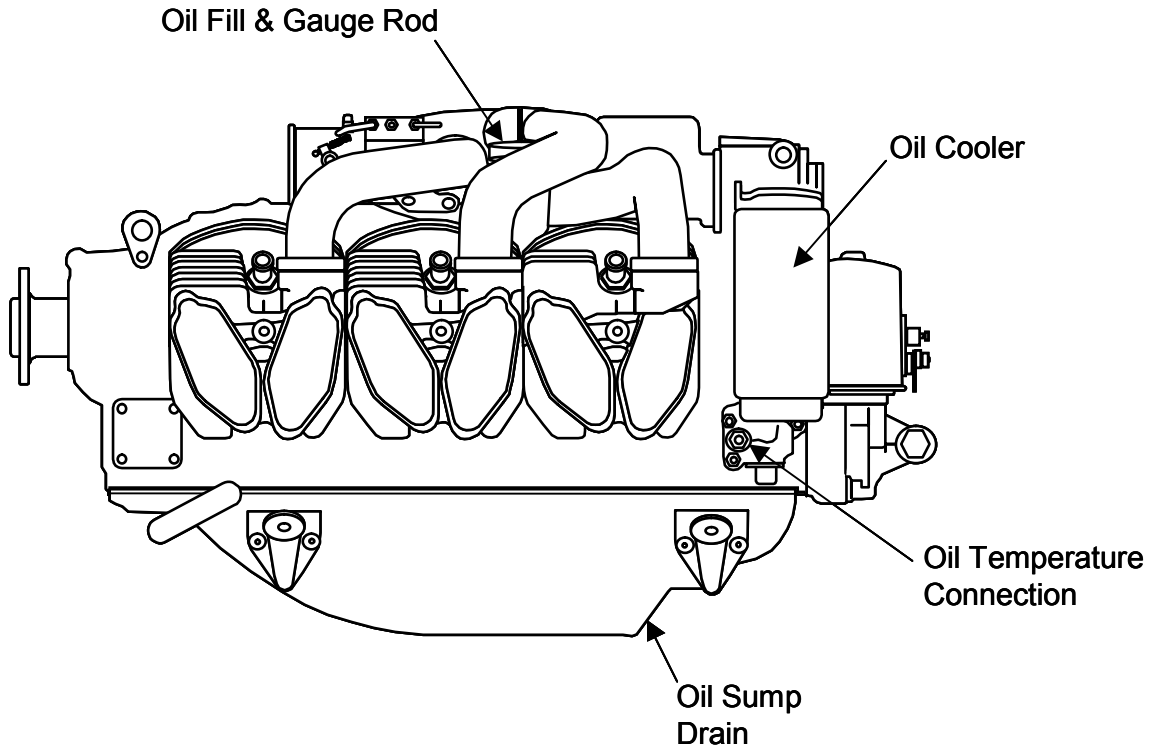

Figure 6-21. IO-550-R Oil Servicing Points

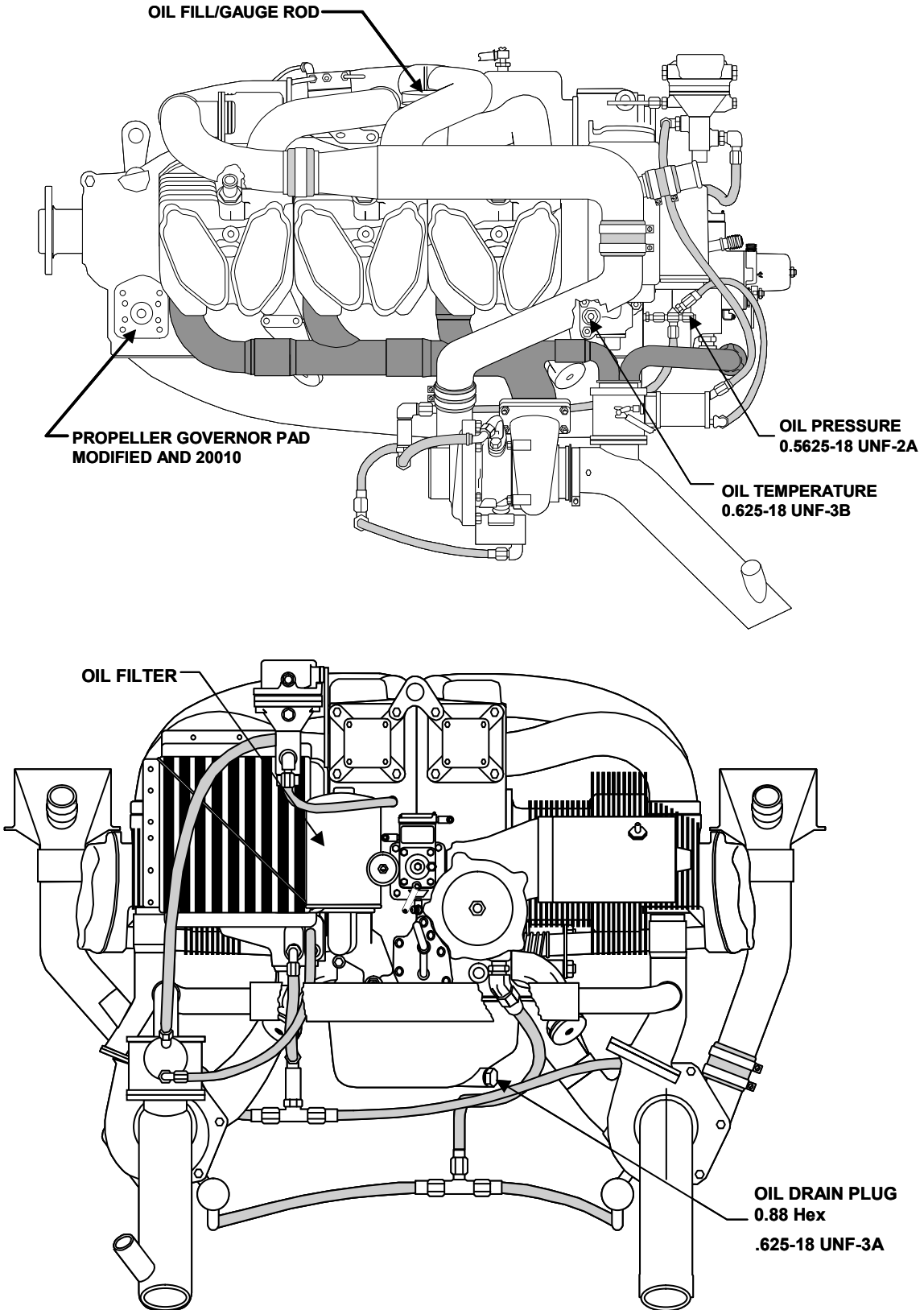

Figure 6-22. TSIO-550 Oil Servicing Points (typical)



6-4.8.2. Oil Change

Perform an oil change within 30 minutes of engine shutdown (to obtain a useful oil sample) according to the oil changes intervals specified in Section 6-2.

NOTE: More frequent oil changes are recommended under extreme usage (flight training, shuttle service, or crop dusting) or adverse (desert or arctic climates) weather conditions.

Procedure

1. Place a catch basin, approved for collecting oil, beneath the oil sump. Remove the oil sump drain plug (Figure 6-7 through Figure 6-22), or quick drain fitting, and drain the oil into the catch basin.
2. Collect an oil sample according to the “Oil Sample Collection” instructions in Section 6-4.8.4. Inspect the oil sump drain plug for evidence of wear material. Metal fragments on the drain plug may indicate excessive wear or part disintegration. Evidence of bronze in the oil sump suggests piston pin bushing loss. Remove the cylinders and inspect the piston pin bushings for proper installation according to instructions in Section 10-10.

CAUTION: Dispose of used engine oil in accordance with local environmental standards.

NOTE: Continental Motors recommends customers submit a sample of the oil drained during each oil change, or if engine trouble is suspected, for spectrographic oil analysis. The first three samples establish the oil analysis trend baseline.

The amount of wear material present in new, rebuilt, or overhauled engines is typically greater during the engine break in period, tapering off during subsequent oil changes. If the amount of wear material does not decrease during subsequent oil changes, note the wear material characteristics (refer to Section 6-4.8.5, “Oil Trend Monitoring and Spectrographic Oil Analysis”) and troubleshoot the engine according to instructions in Chapter 8.

3. Oil Filter or Integral Screen Change

Engines covered in this manual are equipped with either a screw-on, disposable oil filter or an integral screen (Figure 6-23). Maintenance pertaining to the filter media is listed in the “Engine Inspection and Maintenance Schedule” in Section 6-2. To change disposable filters, follow the instructions in step a; for the integral screen, follow the instructions in step b.

- a. Remove the oil filter (Figure 6-8 through Figure 6-22). Cut the oil filter in two parts using an Oil Filter Can Cutter (P/N CT-923 (Table 2-1, “Special Tools List”)).
 - 1) Inspect the oil filter element for metal debris trapped within the filter to assess the engine condition. If debris is found, wash the filter media in a clean glass container to determine content. Use a magnet to differentiate the ferrous materials from non-ferrous particulate.

- 2) New, rebuilt, or overhauled engines exhibit more wear material during the break-in period; material found in the filter media will diminish over time. If wear material in the oil filter does not diminish, or increases, note the characteristics of the wear material (Section 6-4.8.5, “Oil Trend Monitoring and Spectrographic Oil Analysis”) and troubleshoot the engine according to instructions in Chapter 8.

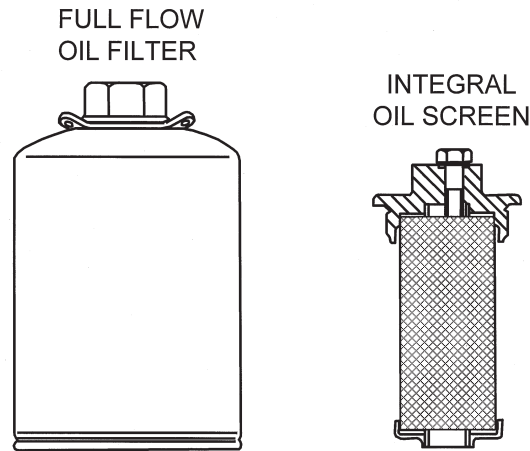

Figure 6-23. Disposable Oil Filter and Integral Screen

- b. If the engine is equipped with an integral oil screen (Figure 6-23), cut the safety wire from the oil screen and remove the fastening hardware. The integral screen is not disposable, rinse the integral screen with mineral spirits over filter paper to clean the media. Use a magnet to differentiate the ferrous materials from non-ferrous particulate.
4. Install the oil filter or screen. For disposable filters, follow the instructions in step a; for the integral screen, follow the instructions in step b.
 - a. Apply a thin coating of Dow Corning DC-4 compound to the oil filter gasket to prevent gasket material sticking to the mating surface. Install the new oil filter; torque the filter to Appendix B specifications and safety wire the filter according to instructions in Section C-3.
 - b. After thorough cleaning, install a new copper gasket on the oil screen flange and install the oil screen in the oil pump, or oil screen adapter. Place a new copper gasket on the plug (or oil temperature sensor provided by aircraft manufacturer) and thread the screen (or plug) in to the housing. Torque to Appendix B specifications and safety wire according to instructions in Appendix C-3.
 5. Reinstall the oil drain plug with a new crush gasket; torque the drain plug to Appendix B specifications and safety wire the drain plug according to instructions in Section C-3.
 6. Add fresh oil and check the oil level according to instructions in Section 6-4.8.1.
 7. Check for oil leaks according to instructions in Section 6-4.8.3.



6-4.8.3. Check for Oil Leaks

WARNING

Keep the engine compartment, nacelle, and fuselage adjacent to the nacelle clean to enable detection of oil leaks.

Procedure

1. Perform a normal “Engine Start” according to instructions in Section 7-3.2 and “Ground Run-up” according to Section 7-3.3 to allow the engine to warm to normal operating temperatures. Document engine oil pressure and temperature.
2. Shut down the engine according to the “Engine Shutdown” instructions in Section 7-3.4.
3. Check the engine nacelle, engine compartment, and adjacent area for oil leaks. If leaks are found, determine the source and correct the cause of the leak(s).
4. Check the oil level in the sump according to Section 6-4.8.1, “Check and Replenish Engine Oil Level.”

6-4.8.4. Oil Sample Collection

Oil samples may be collected during the oil change procedure, before new oil is added or between oil changes. The oil sample must be taken after the engine has been operated within normal operating limits (See Engine Specifications and Operating Limits in primary ICA (**Ref: Section 1-1.1**)), including normal cruise and maximum power settings for at least 30 minutes.

NOTE: Collect oil samples within 30 minutes of engine shutdown.

Procedure

1. Clean any dirt or debris from around the oil sump drain plug.
2. Use the following sample collection devices:
 - a. Sampling tube and/or funnel
 - b. Sample vial

NOTE: Oil sampling equipment must be clean and free of debris, foreign material, or residue to ensure sample integrity and accurate analysis.
3. Collect oil from one of the following sample collection locations consistently according to the Oil Analysis Laboratory’s oil sampling kit instructions:
 - a. Midstream of the oil drain flow after 1/3 of the oil has drained from the oil sump.
 - b. From the oil fill port, at least 2 to 3 inches above the bottom of the oil sump.

NOTE: Never take an oil sample from the bottom of the oil sump or the oil filter canister.
4. Fill the oil sample tube or vial 3/4 full and tighten the cap.
5. Label the oil sample vial with the date the sample was taken, the serial number of engine it was taken from, and the submitter’s name and company.



Engine Inspection and Service

NOTE: Duplicate oil samples, submitted to different oil analysis laboratories will render an equal number of different reports. Establish a rapport with one laboratory and use it consistently for meaningful trend analysis.

6. Submit the oil sample for analysis. The following laboratories provide thorough, detailed oil analysis and reporting:

Aviation Oil Analysis
3319 W. Earll Drive
Phoenix, AZ 85017

Aviation Laboratories
910 Maria Street
Kenner, LA 70062

6-4.8.5. Oil Trend Monitoring and Spectrographic Oil Analysis

Spectrographic oil analysis identifies concentration, in parts per million (PPM), of wear material in an oil sample (see Section 6-4.8.4) collected during an oil change. Analysis begins with the first oil change sample, and continues with successive oil changes. The first samples establish a baseline. Subsequent samples, taken over time, establish trends. These trends help determine if wear material is deviating from the baseline. (Establishment of the baseline and ensuing wear trends assume analysis is done by the same laboratory using the same method of analysis.)

Spectrographic oil analysis results will vary for reasons exclusive of engine condition. Chemical composition of engine oils vary by manufacturer. For consistent, meaningful analysis, service the engine with the appropriate grade of aviation engine oil from the same manufacturer, collect engine oil samples at regular intervals and submit the samples to the same laboratory for analysis.



6-4.9. Ignition System Maintenance

6-4.9.1. Ignition Timing

Reference: **MSB94-8**

Ignition timing instructions apply only to engine models with magneto ignition. For all FADEC engines, consult the primary ICA.

Equipment Required

- Eastern Technology Corporation Model E25 Timing Indicator (or equivalent)
- Top Dead Center Locator
- Eastern Technology Corporation Model E50 timing light (or equivalent)

CAUTION: Ignition timing drift greater than 4 degrees between inspections may be an indication of magneto cam wear or breaker point erosion. Investigate any timing drift greater than 4 degrees.

NOTE: Instructions provided utilize the Eastern Technology Model E25 timing indicator and E50 timing light. If using alternate timing tools, reference the manufacturer's instructions.

NOTE: Instructions to turn the crankshaft clockwise or counterclockwise in Section 6-4.9.1.1 and Section 6-4.9.1.2 reference the pilot's perspective, viewed from behind the propeller. Standing in front of the engine, all directions are opposite of the printed text.

Table 6-7. Magneto Timing Specifications - Geared Engines

Engine Model	Crankshaft Angle	Propeller Shaft Ratio	Propeller Shaft Angle
GO-300	28° BTC	0.75	21° BTC
GIO-470	24° BTC	0.75	18° BTC
GTSIO-520-C	22° BTC	0.75	16.5° BTC
GTSIO-520-D, F, H, K	20° BTC	0.667	13.3° BTC
GTSIO-520-L, M, N	24° BTC	0.667	16° BTC
TIARA 6-285 and 6-320	30° BTC	0.500	15° BTC

Table 6-8. Magneto Timing Specifications - Direct Drive Engines

Engine Model	Right Magneto ¹	Left Magneto ¹	Notes
A65	30° BTC	30° BTC	
A75, A80	29° BTC	32° BTC	
C75, C85	28° BTC	30° BTC	
C90	26° BTC	28° BTC	
O-200-A, B, C	24° BTC	24° BTC	2



Engine Inspection and Service

Table 6-8. Magneto Timing Specifications - Direct Drive Engines

Engine Model	Right Magneto ¹	Left Magneto ¹	Notes
O-200-D	24° BTC	24° BTC	
IO-240-A	22° BTC	22° BTC	
IO-240-B	26° BTC	26° BTC	
C-125	28° BTC	30° BTC	
C-145, O-300	26° BTC	28° BTC	
E-165, E-185, E-225	26° BTC	26° BTC	
O-470-A, E	26° BTC	26° BTC	
O-470-B, G, M, P & U	24° BTC	24° BTC	
O-470-J	20° BTC	20° BTC	
O-470-K, L, R & S	22° BTC	22° BTC	
IO-346	24° BTC	24° BTC	
IO-360-A, B, C, D, G, H, J & K	20° BTC	20° BTC	3
IO-360-AF & ES	24° BTC	24° BTC	
IO-470-C, G, R & P	26° BTC	26° BTC	
IO-470-D, E, F, H, L, M, N, S, U, V & VO	20° BTC	20° BTC	
IO-470-J, & K	22° BTC	22° BTC	
IO-520-A, B, BA, BB, C, CB, D, E, F, L, M, MB, N, NB	22° BTC	22° BTC	
IO-550-A, B, C, D, E, F, G, L, N, P & R	22° BTC	22° BTC	
LTSIO-360-E, EB, KB	20° BTC	20° BTC	
LTSIO-360-RB	22° BTC	22° BTC	
TSIO-470	22° BTC	22° BTC	
LTSIO-520-AE	20° BTC	20° BTC	
TSIO-360-A, AB, B, C, CB, D, DB, E, EB, F, FB, G, GB, H, HB, J, JB, K, KB, LB, MB & SB	20° BTC	20° BTC	
TSIO-360-RB	22° BTC	22° BTC	



Table 6-8. Magneto Timing Specifications - Direct Drive Engines

Engine Model	Right Magneto ¹	Left Magneto ¹	Notes
TSIO-520-B, C, D, E, H, J, K, L, N, VB, WB, AE & CE	20° BTC	20° BTC	3
TSIO520-M, P, R, T, UB & AF	22° BTC	22° BTC	3, 4
TSIO-520-BE	24° BTC	24° BTC	
TSIO-550-A, B, C, E, G, K & N	24° BTC	24° BTC	
TSIOL-550-A & C	20° BTC	20° BTC	
TSIOL-550-B	24° BTC	24° BTC	

1. Allowable tolerance is plus or minus one degree unless otherwise noted.
2. O-200-A and -B model engines that have a complete set (4 each) of Continental Motors Part No. 641917 or subsequent (higher) part number cylinders installed are eligible to have the timing advanced to 28 degrees BTC. This may include a combination of 641917, 649543, 653246, 654377, 653816, 655483, 657454, 657455 and subsequent (higher) part number cylinders. Part No. 641917 was first produced in 1977. The cylinder part number is stamped on the barrel flange. The absence of a cylinder part number may indicate cylinders manufactured prior to Part No. 641917. Visual acceptance can be determined by the examples listed in Figure 6-24 and Figure 6-25. For those engine that have the applicable cylinders and timing advanced, restamp the engine data plate to indicate magneto timing of 28 degrees BTC and make a log book entry noting the change and the part number of the qualifying cylinders installed. Subsequent installation of cylinders must be of the part numbers listed above to retain the advanced 28 degree BTC timing. ONLY cylinders manufactured by Continental Motors qualify for the advanced timing under this manual.
3. Timing specification for "B" Models (i.e. IO-360-DB, IO-520-BB, TSIO-520-EB, etc.) is the same as standard models.
4. Magneto setting tolerance of TSIO-520-P to be plus zero (0) or minus one (1) degree.

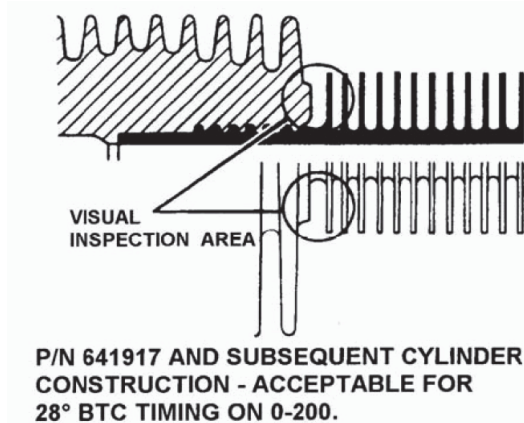

Figure 6-24. O-200 28° BTC Timing

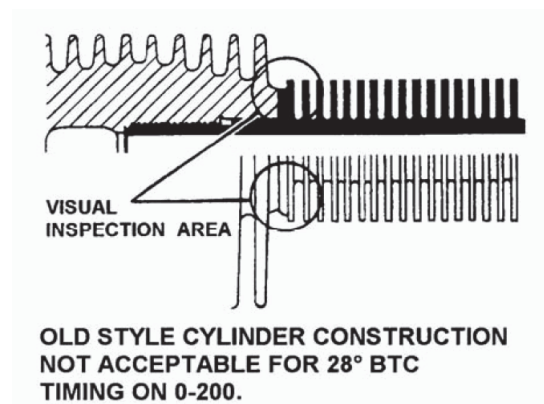

Figure 6-25. O-200 24° BTC Timing



6-4.9.1.1. Crankshaft Top Dead Center Alignment

WARNING

Turn the Ignition Switch OFF and disconnect engine electrical power before commencing maintenance or inspections. Confirm continuity between the magneto capacitor and aircraft ground to prevent accidental engine start during maintenance. Do not stand or place equipment within the arc of the propeller.

CAUTION: Incorrect timing, in addition to a rough running engine, can lead to detonation, pre-ignition, possible internal engine damage, or engine failure.

Gravity affects the timing indicator pendulum position. Prior to checking or adjusting engine timing, level the aircraft (fore to aft) to avoid friction on the pendulum.

NOTE: Some starters restrict reverse engine rotation. If the engine does not freely turn in the opposite direction of normal rotation, temporarily remove the starter to complete magneto to engine timing.

1. Place the fuel selector valve in the OFF position.
2. Turn the ignition switch to the OFF position. Disconnect the aircraft battery according to the aircraft manufacturer's instructions.
3. Remove top spark plugs from each cylinder. Find the No. 1 cylinder compression stroke by placing a finger over the spark plug hole and rotating the crankshaft. When the cylinder is on the compression stroke, the valves will be closed and pressure will build as the piston moves to the top of the cylinder. Pressure buildup in the cylinder can be felt at your fingertip.
4. Install the top dead center (TDC) locator (Figure 6-26) in the No. 1 cylinder spark plug hole.

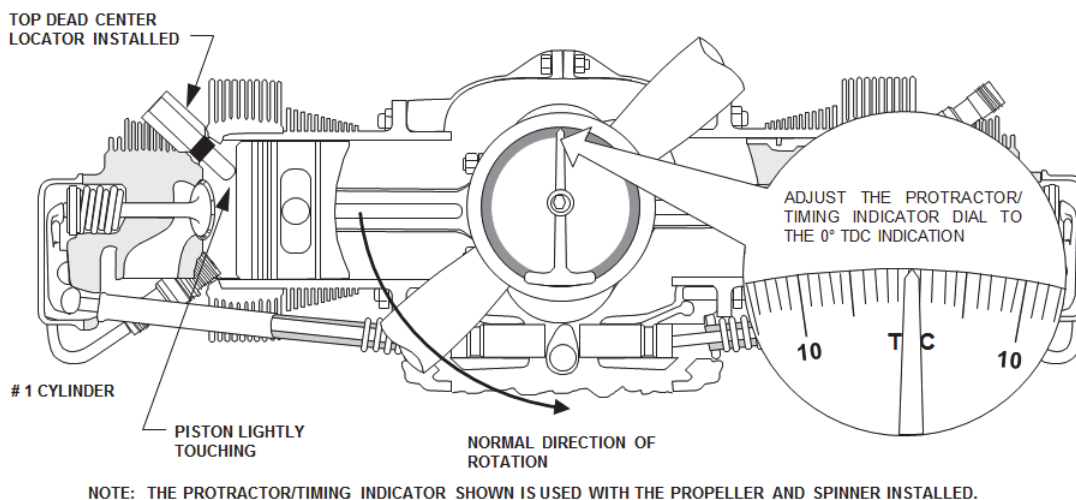
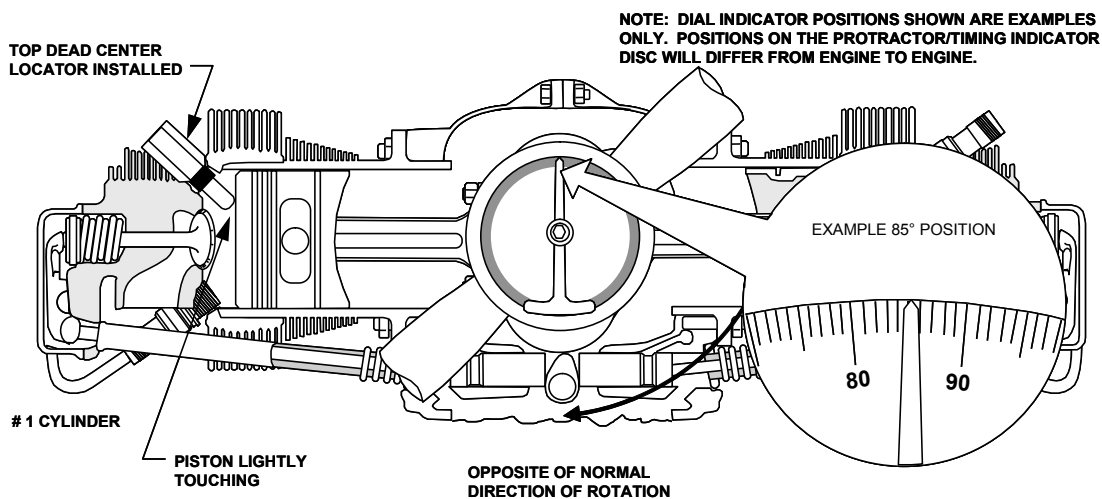

Figure 6-26. Timing Disk and TDC Locator Installed

NOTE: Ensure the timing disk is securely fastened to the propeller to prevent movement during engine timing.

5. Securely install the timing disk indicator on the crankshaft flange, propeller spinner or propeller hub using the supplied elastic bands.
6. Turn propeller slowly in the direction of normal rotation until the piston lightly touches the top dead center locator.
7. Rotate the timing disc until the Top Dead Center (TDC) mark aligns with the weighted pendulum pointer.
8. Slowly rotate the crankshaft in the opposite direction of normal rotation until the piston again lightly touches the top dead center locator (Figure 6-27).



NOTE: THE PROTRACTOR/TIMING INDICATOR SHOWN IS USED WITH THE PROPELLER AND SPINNER INSTALLED.

Figure 6-27. No. 1 Cylinder Positioned at Top of Intake Stroke

9. Determine the difference between TDC and the current pointer indication (Figure 6-27) and divide by two; turn the timing disk to align the pointer with the resulting number (Figure 6-28), without turning the timing indicator base.

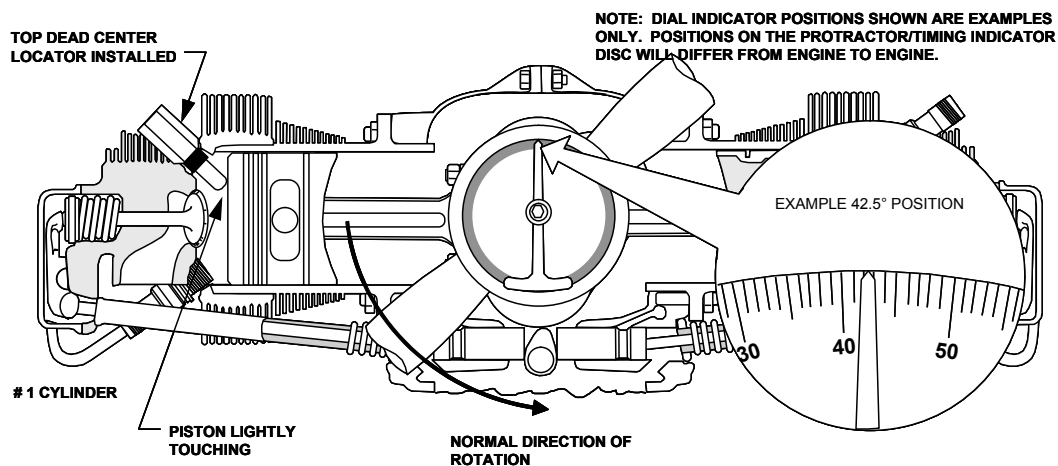

NOTE: THE PROTRACTOR/TIMING INDICATOR SHOWN IS USED WITH THE PROPELLER AND SPINNER INSTALLED.

Figure 6-28. Crankshaft Positioned at TDC



10. Remove the Top Dead Center locator from the No.1 cylinder (Figure 6-29).
11. Rotate the crankshaft in the direction of normal rotation on the compression stroke until the pointer aligns with the 0° mark. On magnetos equipped with impulse couplings, continue turning the crankshaft in the direction of normal rotation until each impulse coupling trips. Couplings may trip a few degrees on either side of TDC. If one or both couplings trip after TDC, rotate the crankshaft opposite of the direction of normal rotation a few degrees before TDC, then back in the direction of normal rotation toward TDC. Impulse couplings should not be armed at this point.
12. For direct drive engines, the crankshaft is now positioned at Top Dead Center (TDC) of the No. 1 cylinder compression stroke, proceed to step 14. For gear driven engines proceed to step 13.

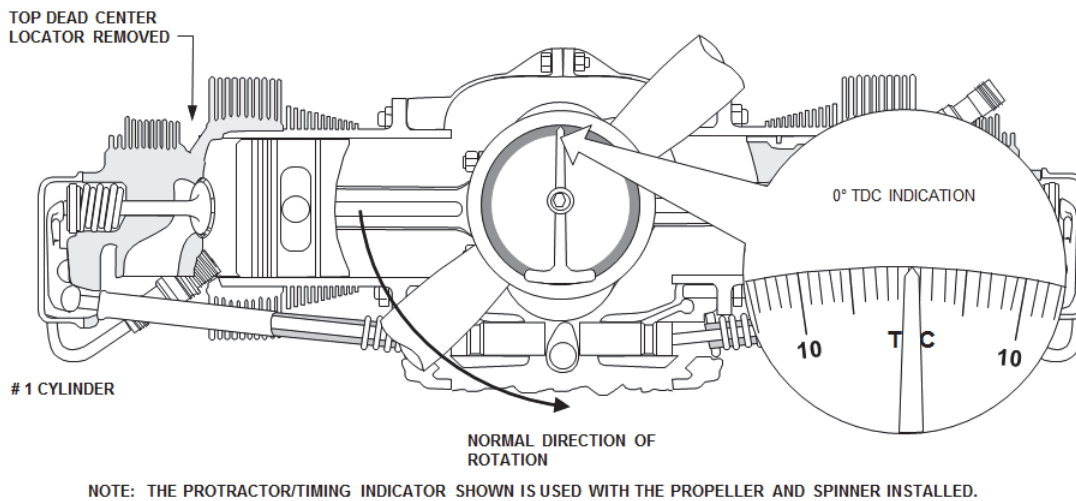

Figure 6-29. Cylinder No. 1 Top of Compression Stroke

13. To determine TDC for geared engines, see the calculations below for the applicable engine model and rotate the propeller shaft accordingly.
 - a. For GO-300, GIO-470 and GTSIO-520-C engine models, add 135 degrees to the value in step 12.
 - b. For GTSIO-520-D, F, H, K, L, M & N engine models, add 120 degrees to the value in step 12.
 - c. For TIARA engine models, add 90 degrees to the value in step 12.

EXAMPLE:

For a geared engine with a 0.75 propeller to crankshaft RPM ratio and timing specification of 24° BTC, the propeller shaft would be 0.75 X 24 degrees or 18° BTC. If the propeller shaft to crankshaft ratio is 0.667, the propeller shaft timing would be 0.667 X 24 degrees, or 16° BTC.



14. Turn the crankshaft in the opposite direction of normal rotation past the engine timing specification to remove gear backlash. Turn the crankshaft in the direction of normal rotation until the pointer aligns with the engine crankshaft timing (**Direct Drive** Table 6-8) or propeller shaft timing angle (**Gear Drive** step 13 and Table 6-8) on the timing disk. The engine is now prepared for magneto removal, installation or magneto to engine timing.

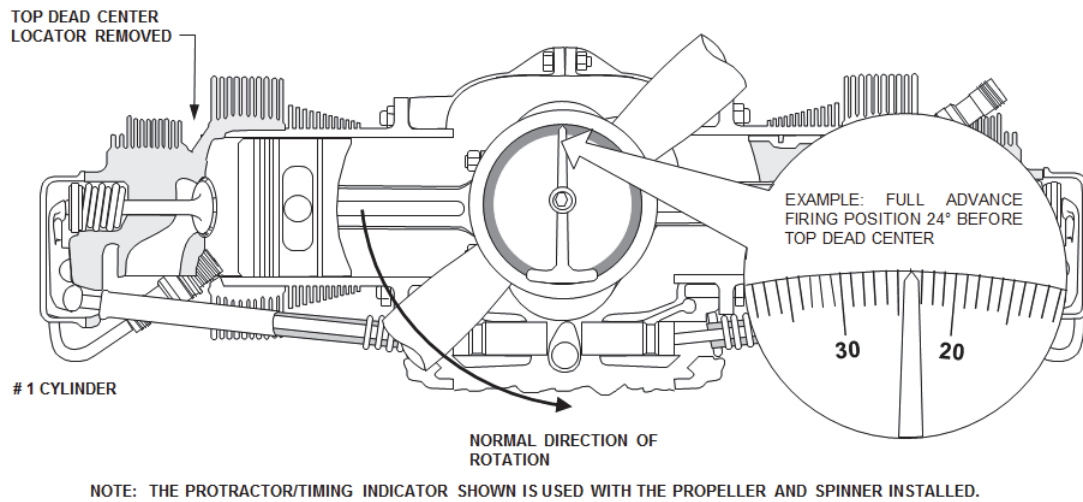

Figure 6-30. No. 1 Cylinder Full Advance Firing Position



6-4.9.1.2. Magneto to Engine Timing

WARNING

Failure to properly maintain the magneto, harness and/or spark plugs will lead to internal engine damage and failure.

CAUTION: Timing Indicator Plate, part number 628760 was discontinued in 1984 due to timing errors attributed to improper use. Use of timing indicator, part number 628760 is prohibited.

Procedure

1. Complete Section 6-4.9.1.1, “Crankshaft Top Dead Center Alignment.”

NOTE: Be familiar with the test equipment function prior to use. Some timing lights indicate proper ignition timing by illuminating a lamp; other models illuminate a lamp until the magneto cam lobe opens the circuit and turns the lamp off while other timing indicators use an audible signal to indicate timing status.

2. Disconnect the P-leads from the magnetos. Connect a timing light right lead to the right magneto switch or P-lead terminal and the left lead to the left switch or P-lead terminal. Connect the timing light ground lead to a suitable ground on the engine such as an unpainted bolt or stud.

NOTE: Engines equipped with impulse coupling magnetos must be turned in the direction of normal rotation past the impulse coupling trip point prior to centering the pointer at engine timing mark.

3. With the crankshaft in the correct timing position, turn the crankshaft opposite the direction of normal rotation a few degrees before the engine timing setting in Table 6-7 to clear valve backlash. Turn the crankshaft in the direction of normal rotation toward the point of ignition and observe the timing light as the needle approaches the engine timing setting. As the pointer aligns with the correct ignition timing, the timing light should indicate proper timing. Lightly tap the end of the pointer with a finger to verify the pointer position.
4. If the timing light fails to illuminate, loosen the nuts securing the magneto to the mounting flange and rotate the magneto to the left or right in the mount until the lamp illuminates. If magneto timing adjustment is not possible, remove the suspect magneto and repair according to the magneto manufacturer's service instructions.

CAUTION: Do not exceed the specified magneto to flange torque. Excessive torque will crack the magneto mounting flange.

5. Torque the magneto fasteners to Appendix B specifications.
6. Remove the protractor and timing disk from the propeller flange, spinner or propeller hub. Reconnect the switch or P-lead wires to the magnetos.
7. Inspect and install spark plugs according to Section 6-4.9.2.
8. Inspect and install the ignition harness according to Section 6-4.9.3.
9. Connect the aircraft battery according to the aircraft manufacturer's instructions.



6-4.9.2. Spark Plug Maintenance

Procedure

1. Remove the ignition harness leads from all spark plugs.
2. Remove the top and bottom spark plug from each cylinder. Mark each plug's installed location during removal.

NOTE: Many spark plug manufacturer's offer erosion (go/no-go) gauges to determine spark plug serviceability. If the spark plug meets the "go" criteria, it may remain in use, if no performance issues are noted.

3. Inspect plug condition using Figure 6-31 as a guide to spark plug serviceability. Discard spark plugs that fail to meet the "normal electrode condition" characteristics depicted in Figure 6-31.
4. Remove and discard the copper gaskets from all reusable spark plugs.

WARNING

Do not install any spark plug that has dropped or exhibits physical damage.

5. If a new spark plug is required, select one from the list in Table 6-9.

	FINE WIRE ELECTRODE	MASSIVE ELECTRODE
NORMAL ELECTRODE CONDITION •INSULATOR TIP GRAY, TAN OR LIGHT BROWN •FEW COMBUSTION DEPOSITS •ELECTRODES NOT BURNED OR ERODED •PROPER TYPE AND HEAT RANGE PLUG FOR ENGINE AND SERVICE. •SPARK PLUG SHOULD BE CLEANED, REGAPPED AND TESTED BEFORE REINSTALLTION		
NORMAL WORN-OUT CONDITION •ELECTRODES ERODED BY HIGH VOLTAGE SPARKING AND BY CORROSIVE GASES FORMED DURING COMBUSTION TO LESS THAN 1/2 ORIGINAL THICKNESS •MORE VOLTAGE NEEDED TO FIRE SPARK PLUGS - OFTEN MORE THAN IGNITION SYSTEM CAN PRODUCE. •REPLACE WITH NEW APPROVED AVIATION SPARK PLUGS.		
SEVERE WORN-OUT CONDITION •EXCESSIVELY ERODED CENTER AND GROUND ELECTRODES PLUS EXTENSIVE NECKING OF FINE WIRE GROUND ELECTRODES INDICATE ABNORMAL ENGINE POWER OR PLUGS LONG OVERDUE FOR REPLACEMENT. •DISCARD SPARK PLUGS AND CHECK HEAT RANGE BEFORE INSTALLING NEW ONES. •REPLACE WITH NEW APPROVED AVIATION SPARK PLUGS IN APPROPRIATE HEAT RANGE.		

Figure 6-31. Spark Plug Inspection Criteria

6. Clean the spark plugs (new or re-used) according to the manufacturer's recommendations. Set the spark plug gap to the spark plug manufacturer's recommended setting for the spark plug part number. If the manufacturer's recommended spark plug gap cannot be located, use the gap specified in Table 6-9.

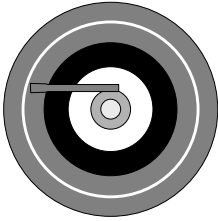
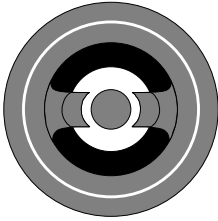
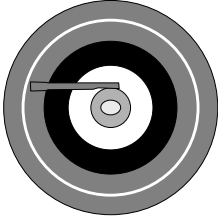
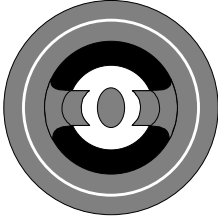
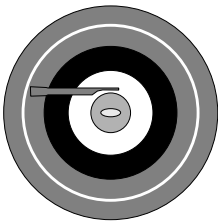
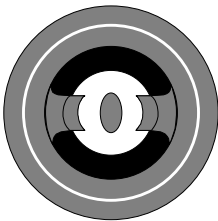

Table 6-9. Spark Plug Application Chart

	Tempest Aviation								Champion Aerospace															
	Manufacturer Part Number	UREM37BY	UREM38E	UREM40E	URHM38E	URHM38EL	URHM38S	URHM40E	URHB32S	URHB32E	M41E	REM37BY	REM38E	REM38S	REM40E	RHM38E	RHM38S	RHM40E	RHB32E	RHB32S	RHB36S	RHU27E	RHU32E	RHU32S
CM Part Number	656082	655902	655899	655915	658565	658475	655914	658474	655908	N/A	N/A	N/A	N/A	N/A	N/A	N/A	N/A	N/A	N/A	N/A	N/A	N/A	N/A	N/A
Barrel Size/Reach ¹	5/8-24S	5/8-24S	5/8-24S	3/4-20S	3/4-20L	3/4-20S	3/4-20S	3/4-20L	3/4-20L	UNSHLD	5/8-24S	5/8-24S	5/8-24S	5/8-24S	3/4-20S	3/4-20S	3/4-20S	3/4-20L	3/4-20L	3/4-20L	3/4-20L	3/4-20XL	3/4-20XL	3/4-20XL
Electrode Gap (recommended)	.016-.021	.016-.021	.016-.021	.016-.021	.016-.021	.017-.020	.016-.021	.017-.020	.016-.021	.016-.021	.016-.021	.016-.021	.016-.021	.016-.021	.016-.021	.016-.021	.016-.021	.016-.021	.016-.021	.016-.021	.016-.021	.016-.021	.016-.021	.016-.021
Engine Model																								
A-40; A-50	X		X				X			X	X			X			X							
A-65; A-75	X		X			X	X			X	X		X	X		X	X							
A-80	X		X				X			X	X			X			X							
A-100										X														
C-75; C-85; C-90	X	X	X	X		X	X			X	X		X	X		X	X							
O-200-A,B,C,D,X	X	X	X	X		X	X			X	X		X	X		X	X							
C-115; C-125	X		X			X	X			X	X		X	X		X	X							
C-145; O-300-A,B,C,D		X	X	X		X	X			X	X	X	X	X		X	X							
GO-300-A,B,C,D,E,F	X	X	X	X		X	X				X	X	X	X	X	X	X							
IO-240-A,B		X		X								X			X									
IOF-240-B					X																			
IO-346-A		X	X	X		X	X					X	X	X	X	X	X							
IO-360-A,AB,C,CB,D,DB,ES,G,GB,H,HB,J,JB,K,KB		X		X		X						X	X		X	X								
IO-360-AF	X																							
L/TGIO-360-A,AB,B,BB,C,CB,D,DB,E,EB,F,FB,G,GB,H,HB,JB,KB,LB,MB,RB,SB		X		X		X						X	X		X	X								
E-165; E-185	X	X	X	X		X	X			X	X	X	X	X	X	X	X							
E-225	X	X	X	X		X	X			X	X		X	X		X	X							
O-470-2		X		X		X						X	X		X	X								



Engine Inspection and Service

CAUTION: Failure to install a new spark plug gasket on each spark plug may result in incomplete sealing of the combustion chamber, loss of spark plug heat transfer, spark plug overheating, possible pre-ignition / detonation and internal engine damage

NOTE: For engines using spark plug thermocouples to report cylinder head temperature, copper gaskets are not required.

7. Install new copper gaskets on all spark plugs.
8. Refer to the spark plug rotation chart (Table 6-10); mark serviceable spark plugs with the respective “TO” cylinder number. For all remaining locations, replace with a new spark plug.

Table 6-10. Spark Plug Rotation Chart

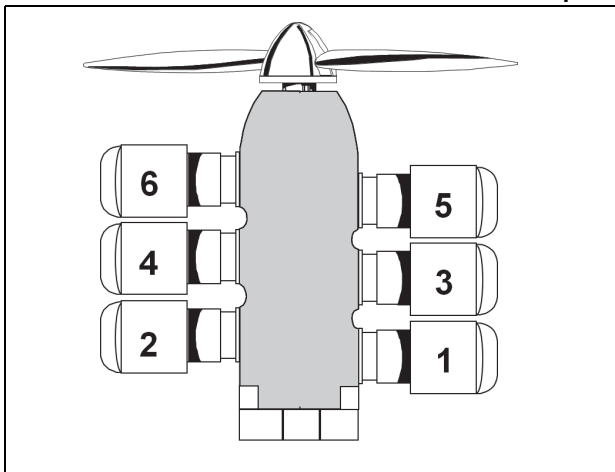

Six Cylinder Spark Plug Rotation	
FROM CYLINDER NUMBER	TO CYLINDER NUMBER
1 TOP	6 BOTTOM
1 BOTTOM	6 TOP
2 TOP	5 BOTTOM
2 BOTTOM	5 TOP
3 TOP	4 BOTTOM
3 BOTTOM	4 TOP
4 TOP	3 BOTTOM
4 BOTTOM	3 TOP
5 TOP	2 BOTTOM
5 BOTTOM	2 TOP
6 TOP	1 BOTTOM
6 BOTTOM	1 TOP

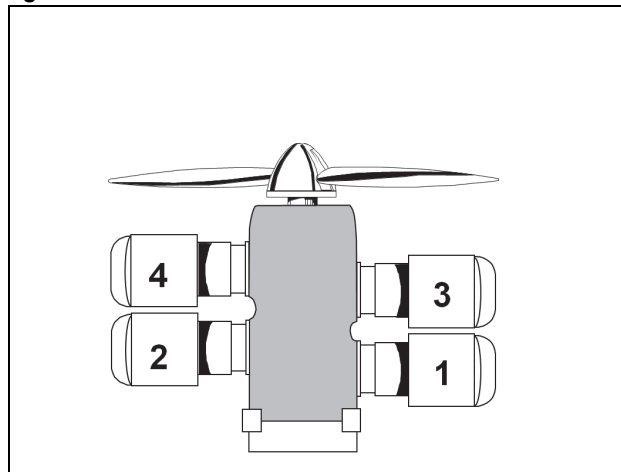

Four Cylinder Spark Plug Rotation	
FROM CYLINDER NUMBER	TO CYLINDER NUMBER
1 TOP	4 BOTTOM
1 BOTTOM	4 TOP
2 TOP	3 BOTTOM
2 BOTTOM	3 TOP
3 TOP	2 BOTTOM
3 BOTTOM	2 TOP
4 TOP	1 BOTTOM
4 BOTTOM	1 TOP

9. Sparingly apply the spark plug manufacturer’s recommended thread lubricant to all except the first row of threads on the spark plug.
10. Thread each spark plug by hand into the engine cylinder head within one to two threads of the gasket. If the spark plug cannot be easily turned, clean the cylinder or spark plug threads.
11. Torque the spark plugs to 300-360 in. lbs. (ref: Appendix B) using a calibrated torque wrench and six-point deep well socket.



6-4.9.3. Ignition Harness Maintenance

NOTE: The cable outlet plates are keyed to attach to the magneto in only one position. No. 1 position marked on the magneto cover aligns with Cylinder No. 1 spark plug firing position.

Procedure

1. Inspect the spark plug leads for chafing, heat damage, wear, and cracking. Replace damaged cables, if repair kits are available or replace the harness.
2. Clean and spray the mating surfaces with MS-122AD spray before installing harness on magneto.
3. Install and tighten three (Champion (Slick)) or four (Continental) screws around the cable outlet plate alternately to seat the cover squarely on magneto. Torque the screws to Appendix B specifications.
4. Refer to the aircraft manufacturer's instructions for specific ignition harness routing instructions. Observe the following when installing the harness on an engine:
 - a. Support leads with the necessary clamps and cable ties to prevent whipping or chafing action. Inter-cylinder baffles are fitted with nut plates to secure ignition harness clamps.
 - b. Refer to the aircraft manufacturer's instructions for routing the ignition through baffling and cushion clamp placement; ensure the ignition harness is not routed in close proximity to the exhaust system.
 - c. Wipe the spark plug lead connector clean using a lint-free cloth moistened with isopropyl alcohol.
 - d. To prevent the sleeves from sticking and minimize twisting of the ferrule, coat the insulating sleeves (see Figure 6-32) with MS-122AD spray.

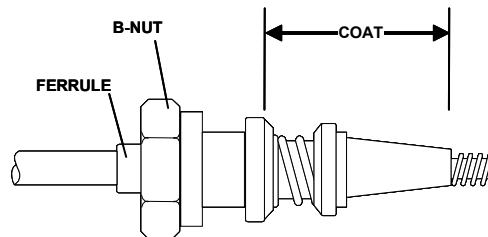

Figure 6-32. Lubricate Ignition Wire with MS-122AD

- e. Apply a light coat of Shell Alvania No. 2 lubricant to the contact point between the nut seat and ferrule on each ignition lead.
- f. Route the ignition leads to the cylinder number and position found on the labels on the loose end of the cable. If the labels are missing or unclear, refer to the ignition harness routing illustrations (in Maintenance and Overhaul (or Overhaul) Manual). Secure the ignition leads to the rocker covers using the ignition lead cushion clamps and rocker cover screws.



5. If the ignition harness includes elbow clamps, install the elbow clamps (Figure 6-33) on the harnesses at the ferrule to prevent harness strain; secure with clamp and screws and lock washers.

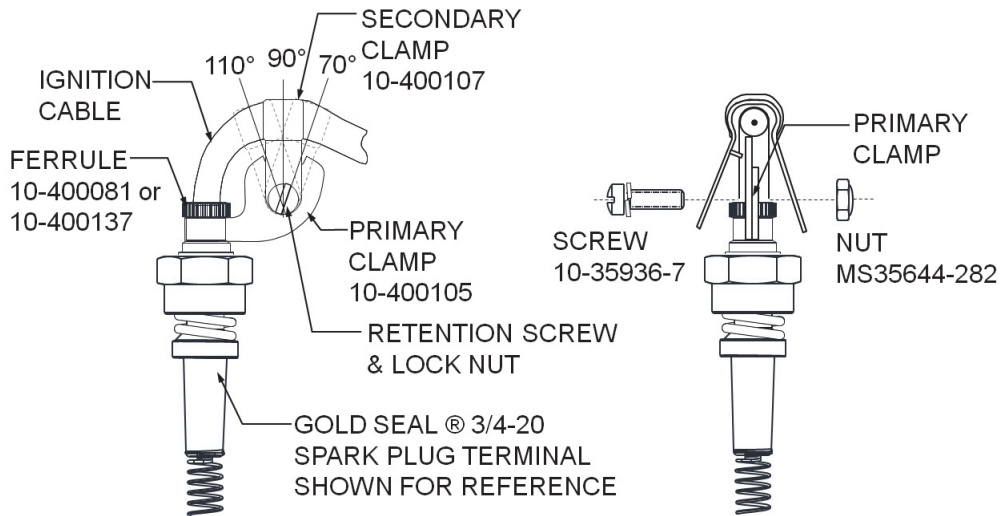

Figure 6-33. Elbow Kit Assembly

6. Verify the inside of the spark plug barrel is clean and dry.
7. Insert the spring-end of the lead into the spark plug barrel. While holding the lead wire B-nut, firmly push the rubber insulator into the spark plug.
CAUTION: Hold ferrules while torquing or loosening spark plug coupling nuts to protect against twisting the ignition cable.
8. Push the ferrule against the spark plug and turn the B-nut clockwise. Continue turning the B-nut until it seats and is finger-tight. While holding the spark plug lead ferrule stationary, torque the B-nut to Appendix B specifications.
9. If all maintenance is complete, perform an “Engine Operational Check” according to the instructions in Section 6-4.7.



6-4.10. Engine Adjustments

NOTE: Before performing any engine fuel system adjustment, verify the aircraft fuel system and fuel pump are operating according to the aircraft manufacturer's specifications and perform an "Engine Operational Check" according to the instruction in Section 6-4.7.

NOTE: For turbocharged engines, Wastegate Controller Adjustment (Section 6-4.10.3) may be required after an engine is installed, rebuilt, serviced, or overhauled.

WARNING

Turn the Ignition Switch OFF and disconnect engine electrical power before commencing maintenance or inspections. Confirm continuity between the magneto capacitor and aircraft ground to prevent accidental engine start during maintenance. Do not stand or place equipment within the arc of the propeller.

WARNING

The procedures listed herein apply to Continental Motors fuel injected engines in their original type design. For modified engine designs, refer to the Supplemental Type Certificate holder information and instructions.

6-4.10.1. Oil Pressure Adjustment

NOTE: Oil pressure on C-75, C-85, C-90, O-200, and O/IO/IOF-240 engine models is not adjustable. Replace the oil pressure relief valve components on these engine if oil pressure is not within acceptable limits.

Procedure

1. Perform an "Oil Pump Operational Check" according to the instructions in Section 6-4.7.3. Adjust oil pressure if the recorded pressure is not within the specified limits.

NOTE: The engine oil temperature must be within normal operating range (see primary ICA) before oil pressure adjustment.

2. Loosen the jam nut securing the oil pressure adjustment screw (see Figure 6-34 for adjustment location).
3. Adjust oil pressure to maintain oil pressure (see "Engine Specifications" section of Primary ICA (30-60 psi for most engines)) at cruise power RPM. To *increase* oil pressure, turn the oil pressure adjusting screw (Figure 6-34) *clockwise (CW)*. To *decrease* oil pressure, turn the oil pressure adjusting screw *counterclockwise (CCW)*.

NOTE: If the jam nut is a lock nut with nylon insert, safety wire is not required on the jam nut.

4. Torque the jam nut to Appendix B specifications and safety wire (if required) the jam nut according to instructions in Appendix C.

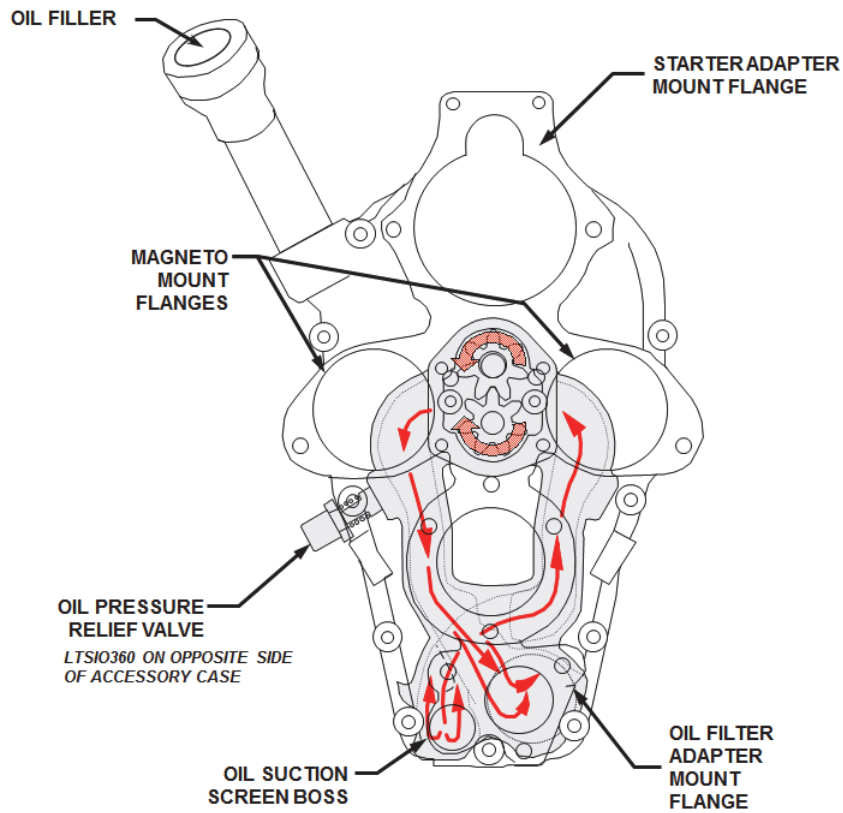

IO/L/TSIO-360 Oil Pressure Adjustment

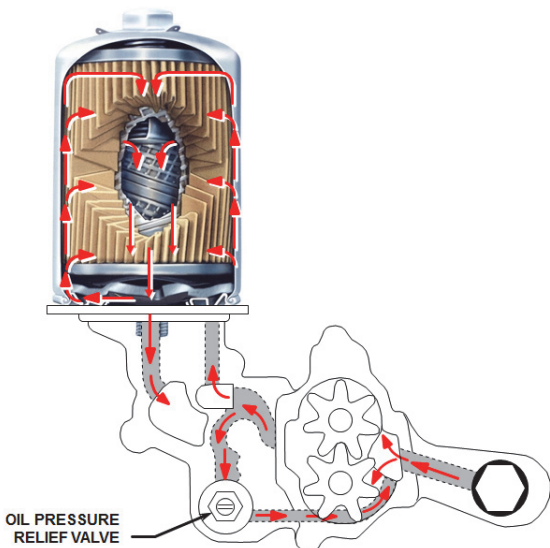

520/550 Permold Oil Pressure Adjustment

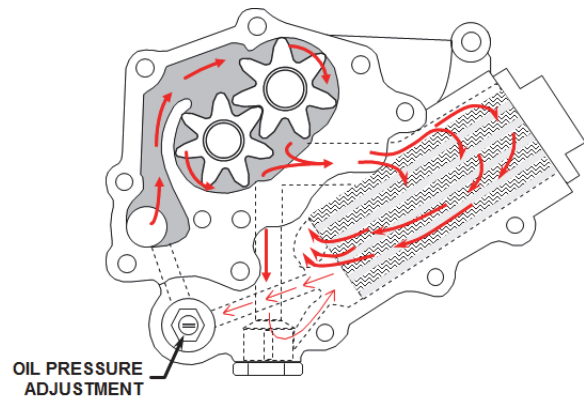

470/520/550 Sandcast Oil Pressure Adjustment with Oil Screen

Figure 6-34. Oil Pressure Relief Valve Adjustment Screw Locations



6-4.10.2. Fuel System Adjustment

Procedure

Perform the “Fuel System Operational Check” according to instructions in Section 6-4.7.4. Record operational check results on a copy of the “Engine Operational Checklist.” Determine adjustment requirements according to results of the Operational Check and make adjustments according to instructions in Section 6-4.10.2.1, Section 6-4.10.2.2, or Section 6-4.10.2.3 applicable to the engine model.

WARNING

Make all adjustments with the engine stopped and the Ignition Switch and Master Power Switch in the OFF position!

6-4.10.2.1. Naturally Aspirated Engine Standard Fuel Pump Adjustments

Procedure

1. Unmetered Fuel Pump Pressure:
 - a. Loosen the jam nut on the fuel pump low pressure relief valve assembly (Figure 6-35 or Figure 6-36).
 - b. Turn the low pressure relief valve adjustment screw *clockwise (CW)* to *increase* unmetered fuel pump pressure, or *counter-clockwise (CCW)* to *decrease* unmetered fuel pump pressure.

NOTE: After each fuel system adjustment, restart the engine and operate the engine at 1500 to 1800 rpm for 15 seconds to clear the engine, then position throttle for desired checks.

- c. Tighten the jam nut on the low pressure relief valve adjustment screw but do not torque at this time; further adjustment may be required.

NOTE: Maximum part throttle full rich fuel flow will be achieved by setting the idle RPM unmetered fuel pump pressure to the minimum value specified. **With the idle RPM fuel/air mixture properly adjusted (after step 2, below), the fuel control metering plate orifices are indexed to the maximum open position.**

2. Idle Mixture Adjustment
 - a. Identify the illustration (Figure 6-37 or Figure 6-39) that matches the fuel system being adjusted. Adjust the idle mixture setting to achieve the idle mixture rise (Section 6-4.7.4, step 14) according to the direction depicted in the illustration. Recheck the unmetered fuel pressure (Section 6-4.7.4, step 13) and idle mixture rise (Section 6-4.7.4, step 14) and adjust, as necessary, until the fuel system settings are adjusted within the specified limits.



3. Full Power Metered Fuel Pressure Adjustment

WARNING

Wear eye protection when cutting safety wire to avoid injury from flying debris.

- a. If installed in an X-pattern through the adjustable orifice, cut and remove the safety wire from the adjustable orifice housing (Figure 6-35 or Figure 6-36). Adjust the safety wire routing through two adjacent sides of the housing and the adjacent plug, next to the adjustable orifice housing on the fuel pump.

CAUTION: The adjustable orifice screw is a tapered needle and may become damaged if forced against its seat. This adjustment should move freely. Do not continue adjustments if rotational resistance increases suddenly.

- b. Turn the adjustable orifice screw clockwise (**CW**) to increase or counterclockwise (**CCW**) to decrease metered fuel pressure.
4. Recheck unmetered fuel pump pressure, idle mixture rise, and full power metered fuel pressure until all are within the specified limits (Section 6-4.7.1).
5. After final adjustments are complete, carefully torque the jam nut on the low pressure relief valve to Appendix B specifications without disturbing the fuel system adjustments. Do not exceed lock nut torque limits.
6. Recheck unmetered fuel pump pressure, idle mixture rise, and full power metered fuel pressure to verify fastener torque did not affect fuel system adjustments. If values are not within specified limits, repeat the adjustment procedures.

WARNING

Make all adjustments with the engine stopped and the Ignition Switch and Master Power Switch in the OFF position!

NOTE: After each fuel system adjustment, restart the engine and operate the engine at 1500 to 1800 rpm for 15 seconds to clear the engine, then position throttle for desired checks.

7. IDLE RPM Adjustment

After adjusting fuel pressures to meet specifications, adjust the IDLE RPM to the desired setting that provided smooth operation with minimal control adjustment for ground operation. Do not adjust the IDLE setting below the minimum setting.

- a. Turn the idle RPM adjustment screw until the end of the screw contacts the throttle stop pin.
- b. Turn the idle RPM adjustment screw clockwise (**CW**) to increase idle RPM or counter-clockwise (**CCW**) to decrease idle RPM.

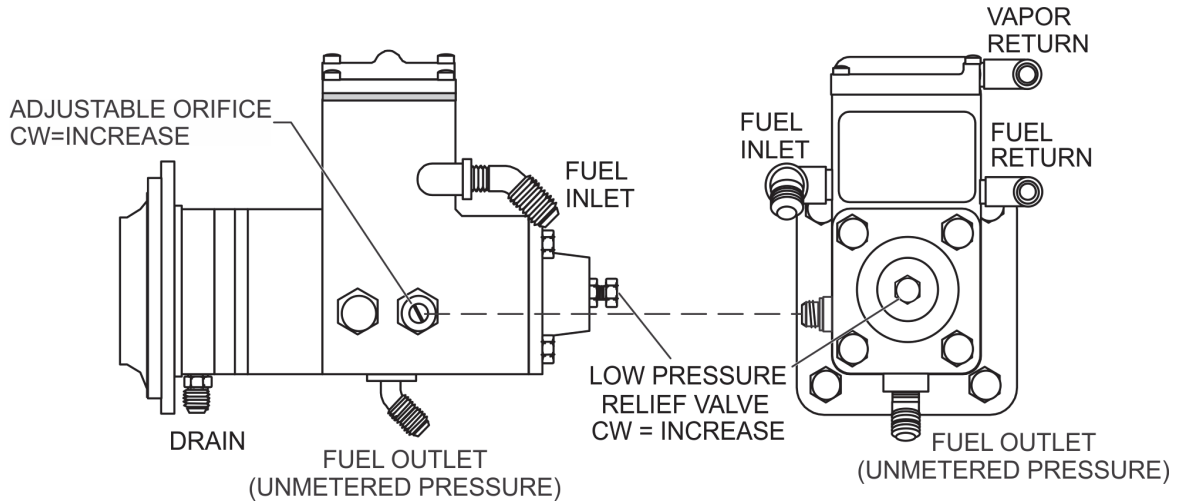

Figure 6-35. Fuel Pump, Naturally Aspirated Engine without integral Mixture Control

CAUTION: The adjustable orifice screw is a tapered needle and may become damaged if forced against its seat. This adjustment should move freely. Do not continue adjustments if rotational resistance increases suddenly.

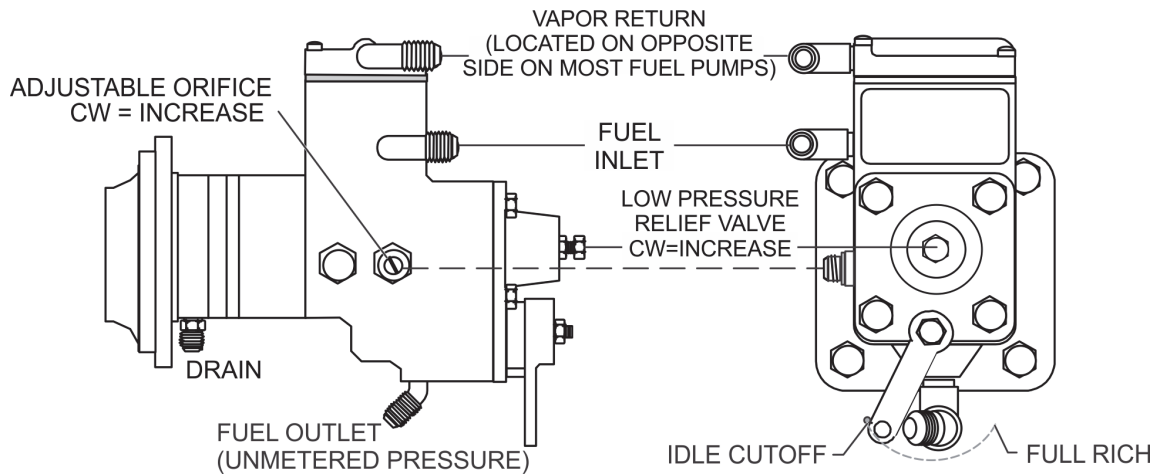

Figure 6-36. Fuel Pump, Naturally Aspirated Engine with integral Mixture Control

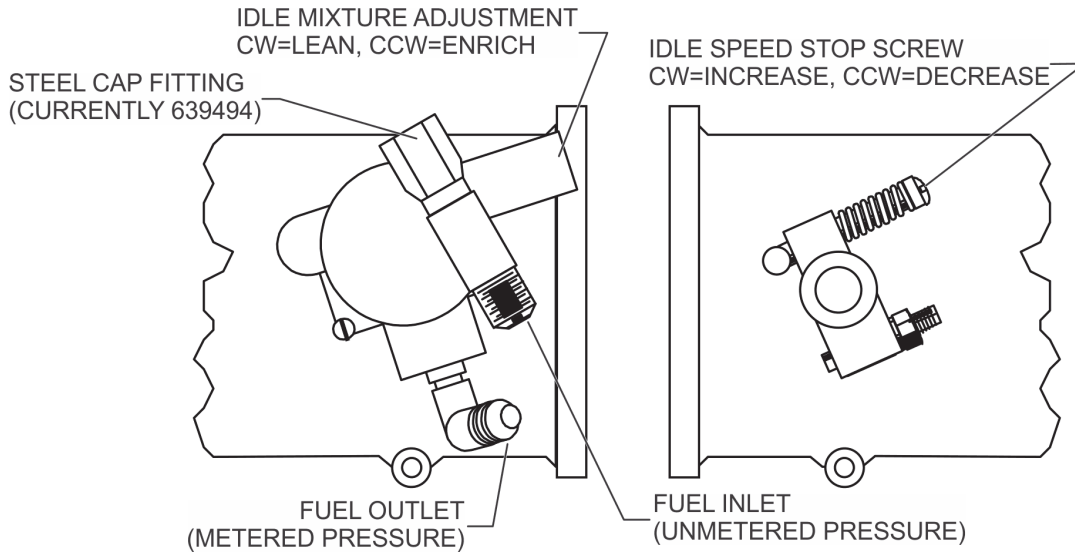

Figure 6-37. Throttle and Metering Assembly

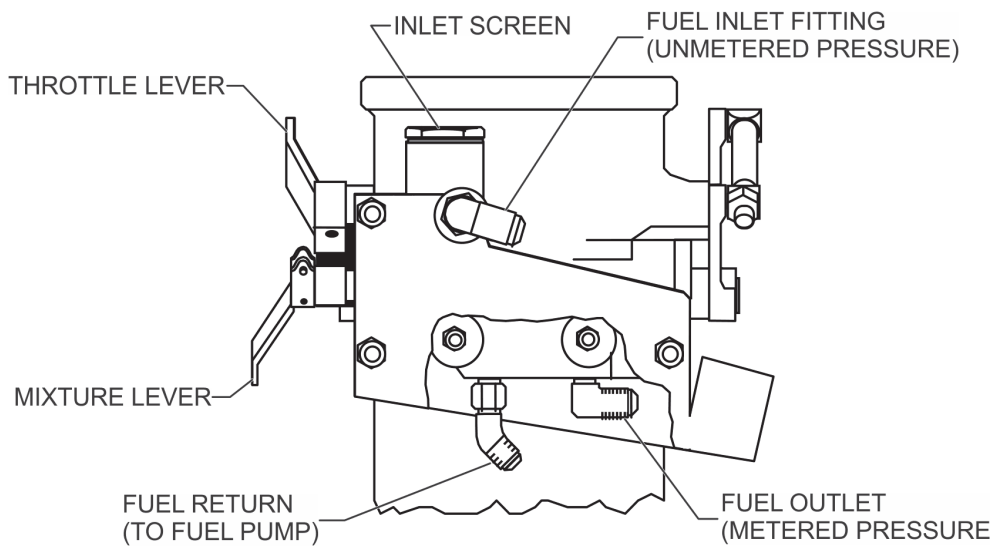

Figure 6-38. Throttle and Control Assembly, Front View

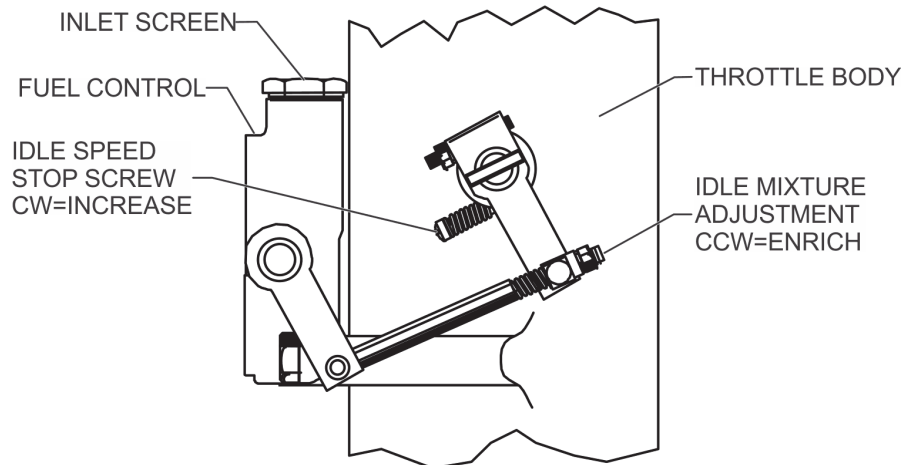
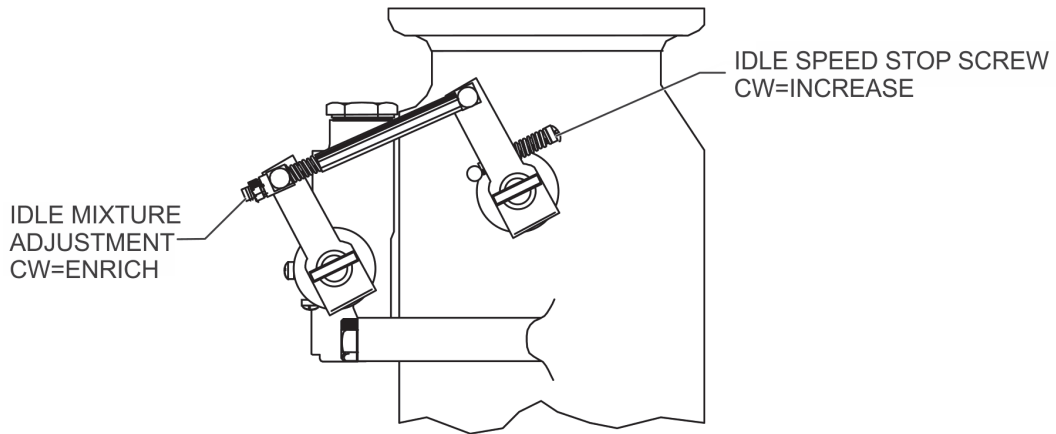

Figure 6-39. Throttle and Control Assembly, Side View



6-4.10.2.2. Naturally Aspirated Engine with Altitude Compensating Fuel Pump Adjustments

WARNING

Make all adjustments with the engine stopped and the Ignition Switch and Master Power Switch in the OFF position!

NOTE: After each fuel system adjustment, restart the engine and operate the engine at 1500 to 1800 rpm for 15 seconds to clear the engine, then position throttle for desired checks.

Procedure

1. Unmetered Fuel Pump Pressure:
 - a. Loosen the jam nut on the fuel pump low pressure relief valve assembly (Figure 6-35 or Figure 6-36).
 - b. Turn the low pressure relief valve adjustment screw *clockwise (CW)* to increase unmetered fuel pump pressure, or *counter-clockwise (CCW)* to decrease unmetered fuel pump pressure.
 - c. Tighten the jam nut on the low pressure relief valve adjustment screw but do not torque at this time; further adjustment may be required.

NOTE: Maximum part throttle full rich fuel flow will be achieved by setting the idle RPM unmetered fuel pump pressure to the minimum value specified. **With the idle RPM fuel/air mixture properly adjusted (after step 2, below), the fuel control metering plate orifices are indexed to the maximum open position.**

2. Idle Mixture Adjustment
 - a. Identify the illustration (Figure 6-37 or Figure 6-39) that matches the fuel system being adjusted.
 - b. Adjust the idle mixture setting to achieve the idle mixture rise (Section 6-4.7.4, step 14) according to the direction depicted in the illustration. Adjust the idle mixture setting to achieve the idle mixture rise (Section 6-4.7.4, step 14) according to the direction depicted in the illustration. Recheck the unmetered fuel pressure (Section 6-4.7.4, step 13) and idle mixture rise (Section 6-4.7.4, step 14) and adjust, as necessary, until the fuel system settings are adjusted within the specified limits.

3. Full Power Metered Fuel Pressure Adjustment:

CAUTION: The adjustable orifice screw is a tapered needle valve and may become damaged if forced against its seat. This adjustment should move freely. Do not continue adjustments if rotational resistance increases suddenly.

- a. On naturally aspirated engines with an adjustable orifice screw (Figure 6-41), turn the adjustable orifice screw clockwise (*CW*) to increase or counterclockwise (*CCW*) to decrease metered fuel pressure.



b. *On naturally aspirated engines without an adjustable orifice screw:*

CAUTION: The aneroid adjustment screw has an extra fine thread; exceeding jam nut torque will damage either the adjustable aneroid stem or housing threads. Jam nut torque value is 25-30 inch pounds.

- 1) Loosen the aneroid adjustment screw jam nut (Figure 6-40).
- 2) Turn the aneroid adjustment screw counter-clockwise (**CCW**) to increase full power, metered fuel pressure; turn the screw clockwise (**CW**) to decrease full power metered fuel pressure.
4. Recheck unmetered fuel pump pressure, idle mixture rise, and full power metered fuel pressure until all are within the specified limits (Section 6-4.7.1).
5. After final adjustments are complete, carefully torque the jam nut on the low pressure relief valve to 25-30 in. lbs. without disturbing the fuel system adjustments. Do not exceed jam nut torque limits.
6. Recheck unmetered fuel pump pressure, idle mixture rise, and full power metered fuel pressure to verify fastener torque did not affect fuel system adjustments. If values are not within specified limits, repeat adjustment procedures.
7. IDLE RPM Adjustment

After adjusting fuel pressures to meet specifications, adjust the IDLE RPM to the desired setting that provided smooth operation with minimal control adjustment for ground operation. Do not adjust the IDLE setting below the minimum setting.

 - a. Turn the idle RPM adjustment screw until the end of the screw contacts the throttle stop pin.
 - b. Turn the idle RPM adjustment screw clockwise (**CW**) to increase idle RPM or counter-clockwise (**CCW**) to decrease idle RPM.

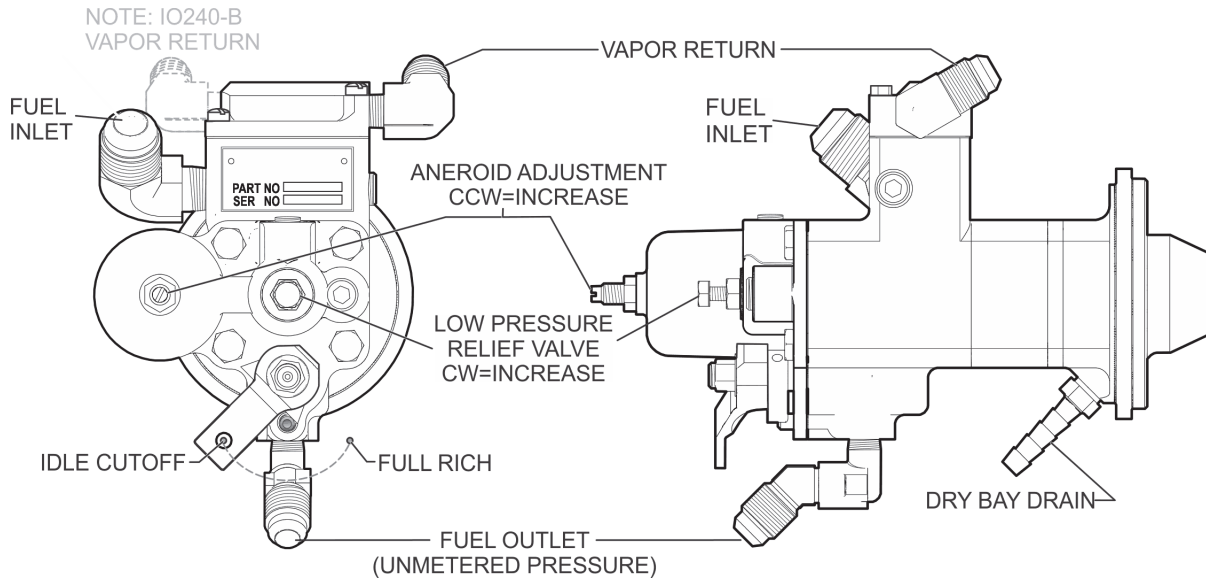

Figure 6-40. Altitude Compensating Fuel Pump (Auto-Lean), Naturally Aspirated Engine (without adjustable orifice)

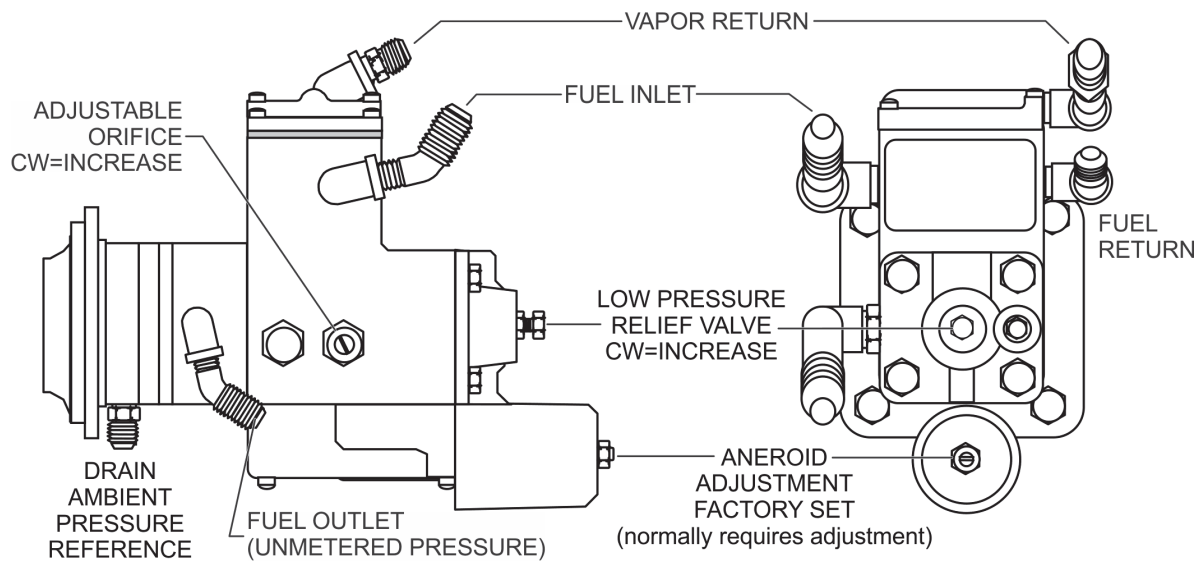

Figure 6-41. Altitude Compensating Fuel Pump (Auto-Lean), Naturally Aspirated Engine (with adjustable orifice)



6-4.10.2.3. Turbocharged Engine Fuel Pump Adjustments

WARNING

Make all adjustments with the engine stopped and the Ignition Switch and Master Power Switch in the OFF position!

NOTE: After each fuel system adjustment, restart the engine and operate the engine at 1500 to 1800 rpm for 15 seconds to clear the engine, then position throttle for desired checks.

1. Unmetered Fuel Pump Pressure:
 - a. Loosen the jam nut on the fuel pump low pressure relief valve assembly (Figure 6-42 or Figure 6-43).

NOTE: Maximum part throttle full rich fuel flow will be achieved by setting the idle RPM unmetered fuel pump pressure to the minimum value specified. **With the idle RPM fuel/air mixture properly adjusted (after step 2, below), the fuel control metering plate orifices are indexed to the maximum open position.**

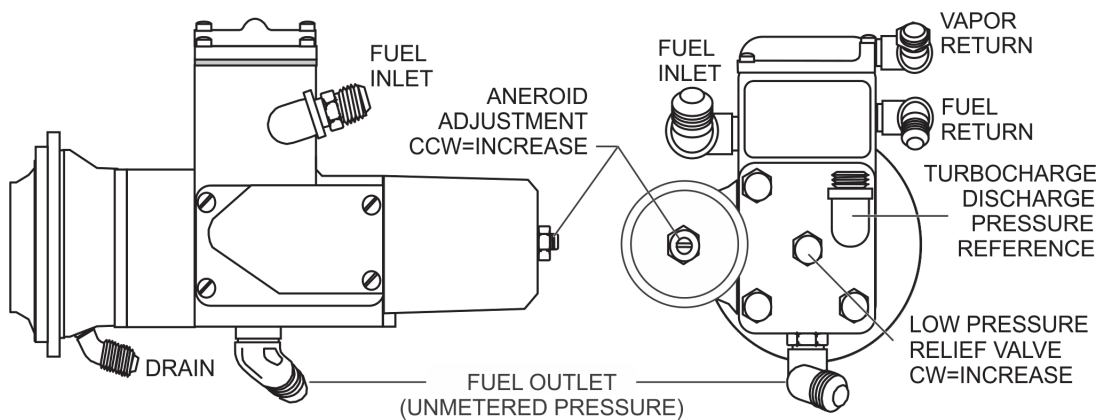

Figure 6-42. Aneroid Equipped Fuel Pump, Turbocharged Engine

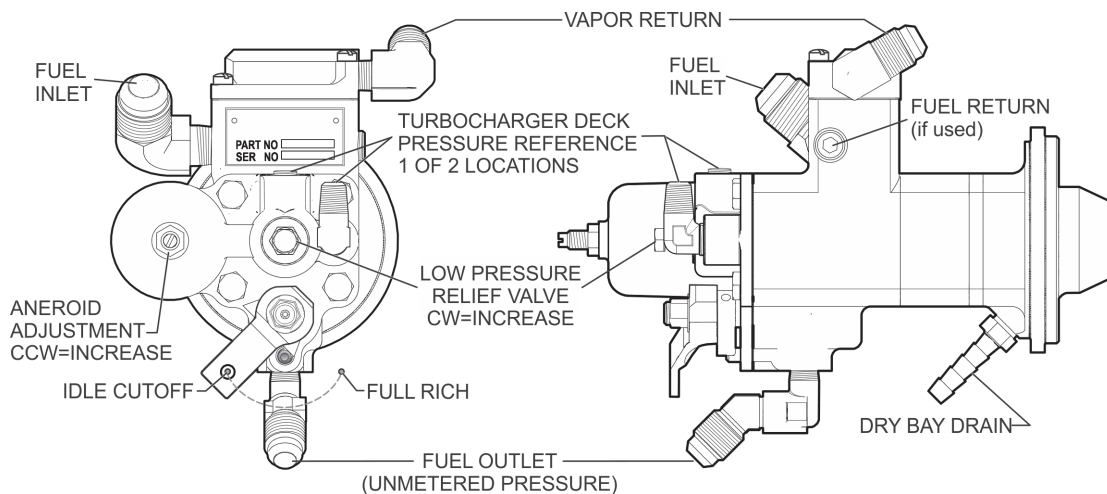

Figure 6-43. Aneroid and Mixture Control Equipped Fuel Pump, Turbocharged Engine



- b. Turn the low pressure relief valve adjustment screw clockwise (*CW*) to increase unmetered fuel pump pressure, or counter-clockwise (*CCW*) to decrease unmetered fuel pump pressure.
 - c. Tighten the jam nut on the low pressure relief valve adjustment screw but do not torque at this time; further adjustment may be required.
2. Idle Mixture Adjustment
- a. Identify the illustration (Figure 6-37 or Figure 6-39) that matches the fuel system being adjusted. Adjust the idle mixture setting according to the direction depicted in the illustration to achieve the idle mixture rise (Section 6-4.7.4, step 14). Adjust the idle mixture setting to achieve the idle mixture rise (Section 6-4.7.4, step 14) according to the direction depicted in the illustration. Recheck the unmetered fuel pressure (Section 6-4.7.4, step 13) and idle mixture rise (Section 6-4.7.4, step 14) and adjust, as necessary, until the fuel system settings are adjusted within the specified limits.
3. Full Power Metered Fuel Pressure Adjustment
- a. *On turbocharged engines without a fuel pressure regulator*, loosen the jam nut (Figure 6-42 or Figure 6-43) on the aneroid adjustment screw.
 - 1) Turn the aneroid adjustment screw counter-clockwise (*CCW*) to increase full power, metered fuel pressure; turn the screw clockwise (*CW*) to decrease full power metered fuel pressure.
 - 2) Tighten the jam nut on the aneroid adjustment screw to secure the setting; do not torque at this time.
 - b. *On turbocharged engines equipped with a fuel pressure regulator*, perform a final adjustment to the FULL POWER metered fuel pressure and fuel flow:

NOTE: On turbocharged engines equipped with a fuel pressure regulator, the FULL POWER metered fuel pressure and fuel flow must be adjusted to five (5) percent higher than the maximum specified limit when regulator is disconnected to ensure adequate part-throttle fuel flow.

 - 1) Turn the aneroid adjustment screw counter-clockwise (*CCW*) to increase full power, metered fuel pressure; turn the screw clockwise (*CW*) to decrease full power metered fuel pressure.
 - 2) Tighten the jam nut on the aneroid adjustment screw to secure the setting; do not torque at this time.
 - 3) Reconnect the fuel pressure regulator (Figure 6-44); torque connections to the Appendix B specifications.
 - 4) Loosen the jam nut on the regulator adjustment set screw.
 - 5) Turn the regulator adjustment screw clockwise (*CW*) to increase or counterclockwise (*CCW*) to decrease metered fuel pressure and fuel flow.
4. Recheck unmetered fuel pump pressure, idle mixture rise, and full power metered fuel pressure until all are within the specified limits (Section 6-4.7.1).



5. After final adjustments are complete, carefully torque the jam nut on the low pressure relief valve to 25-30 in. lbs. without disturbing the fuel system adjustments. Do not exceed jam nut torque limits.
6. Recheck unmetered fuel pump pressure, idle mixture rise, and full power metered fuel pressure to verify fastener torque did not affect fuel system adjustments. If values are not within specified limits, repeat the adjustment procedures.
7. IDLE RPM Adjustment
After adjusting fuel pressures to meet specifications, adjust the IDLE RPM (Figure 6-37 or Figure 6-39) to the desired setting that provided smooth operation with minimal control adjustment for ground operation. Do not adjust the IDLE setting below the minimum IDLE RPM setting (Section 6-4.7.1) for the engine model.
 - a. Turn the idle RPM adjustment screw until the end of the screw contacts the throttle stop pin.
 - b. Turn the idle RPM adjustment screw clockwise (**CW**) to increase idle RPM or counter-clockwise (**CCW**) to decrease idle RPM.

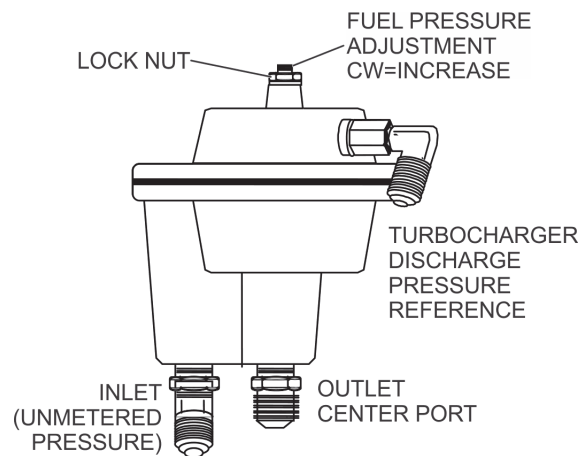

Figure 6-44. Fuel Pressure Regulator, Turbocharged Engine



6-4.10.2.4. Fuel Pump Auto-Lean Schedule Adjustment

NOTE: Auto-leaning is a function of naturally aspirated engines equipped with altitude compensating fuel pumps. Turbocharged engines with aneroid fuel pumps react to upper deck pressure reference pressure, not atmospheric pressure.

NOTE: On IO-550-A and C model engines, do not attempt to adjust the auto-leaning schedule if the aircraft is at a field altitude greater than 1000 feet. On IO-550-B, D, E, F and L model engines, do not attempt to adjust the auto-leaning schedule if the aircraft is at a field altitude greater than 3000 feet.

1. If not previously accomplished, perform an “Engine Operational Check” (Section 6-4.7) and “Flight Check” (Section 7-2.4.2), and adjust, as required, to meet the “Fuel Injection System Specifications” in Section 6-4.7.1.

CAUTION: The aneroid adjustment screw has an extra fine thread; exceeding jam nut torque will damage either the adjustable aneroid stem or housing threads. Jam nut torque value is 25-30 inch pounds.

2. Adjustments to the altitude compensating fuel pump aneroid adjustment screw will result in a change to the auto-leaning schedule (see Figure 6-47 through Figure 6-53). One complete revolution of the aneroid adjustment screw will increase or decrease the auto-leaning schedule approximately 1000 feet. Make adjustment in **small increments** to avoid drastic changes to fuel pump operating characteristics.
3. Turn the aneroid adjustment screw clockwise to decrease the altitude (move horizontally to the left on the chart); turn the aneroid adjustment screw counterclockwise to increase the altitude (moves horizontally to the right on the chart) at a given pressure altitude.
4. Adjustments to the aneroid may affect the full power unmetered fuel pressure, metered pressure, fuel mixture, and fuel flow. **It is important to maintain the balance between these adjustments in order to achieve the specified fuel system parameters.** Further re-adjustment of the adjustable orifice (metered fuel pressure adjustment in Section 6-4.10.2) may be necessary after setting the auto-leaning schedule.

CAUTION: The adjustable orifice screw is a tapered needle and may become damaged if forced against its seat. This adjustment should move freely. Do not continue adjustments if rotational resistance increases suddenly.

5. If fuel flow on the chart is too lean or too rich, fine adjustments to the adjustable orifice (see Figure 6-41) will correct vertical offset errors on the chart (Figure 6-45), by increasing or decreasing fuel flow.
6. Review the Flight Check portion of the “Engine Operational Checklist” to determine if the auto-leaning schedule is set to the “specified limits” for the engine model (reference Table 6-17 and Figure 6-53 for IO-550-D engine model). Use the following example to correct altitude offset errors and set the auto-leaning schedule:



- a. The plotted engine performance depicted by the black stars in Figure 6-45 begins within the lower limit of the engine operating range, drifts below the minimum fuel flow, and returns to near the lower limit of the operating range in the chart.

NOTE: Aneroid adjustments move the plotted performance horizontally across the chart.

- b. The goal, during adjustment, is to reposition the plotted performance as close to the optimum fuel flow (represented by the dashed line) across the fuel pump specifications in the chart (the midpoint between the upper and lower fuel flow limits, according to Table 6-17).

- c. Select a point along the plotted performance curve. In this example, we will use 4000 feet, as point “A”. In order to make the fuel pump conform to the performance curve, we move horizontally across the chart to the midpoint between the upper and lower limits on the target curve, called point “B” (see Figure 6-45).

- d. The horizontal distance between points “A” and “B” is 2000 ft. This value represents the ALTITUDE OFFSET ERROR (Figure 6-45).

NOTE: Rotating the aneroid adjustment screw (increase/decrease) corrects the altitude offset in the altitude leaning schedule.

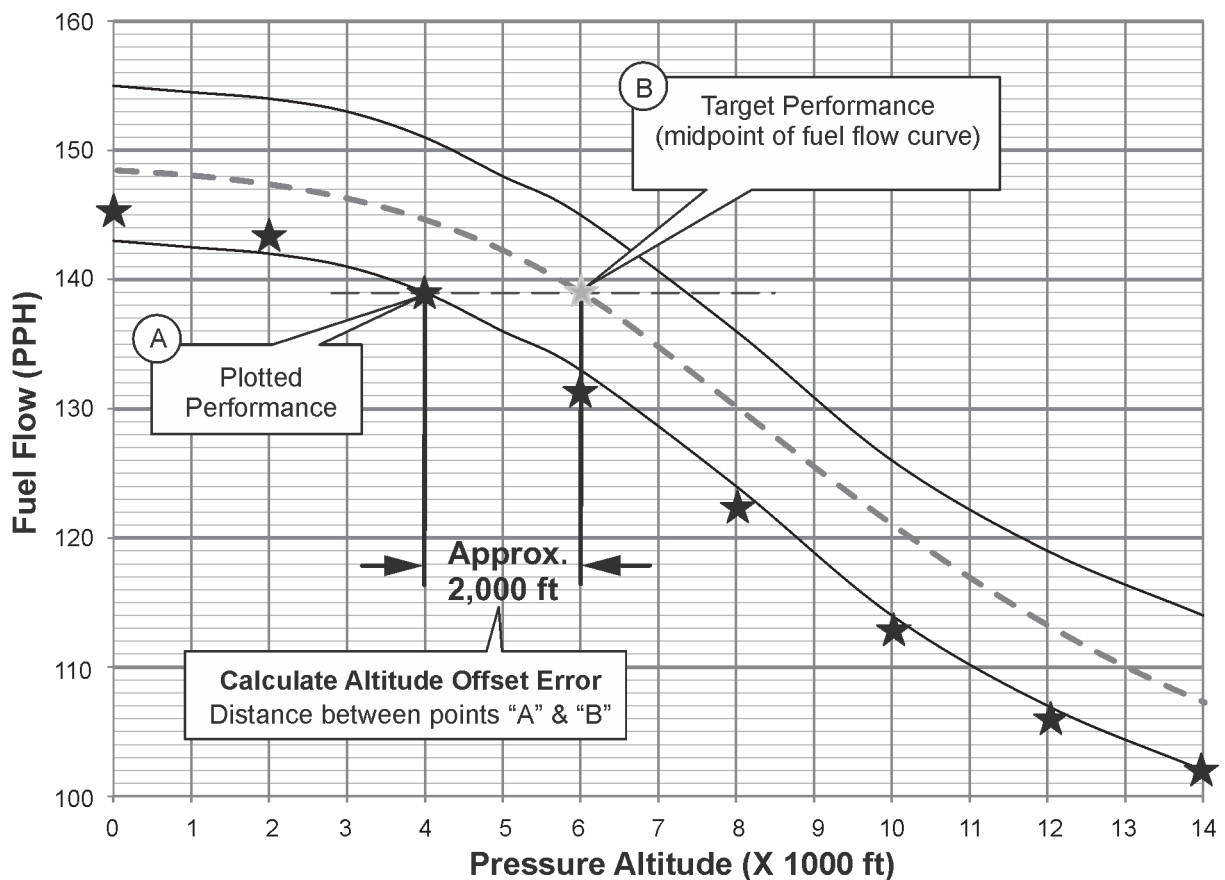

Figure 6-45. Altitude Leaning Schedule Adjustment Example



Engine Inspection and Service

- e. To achieve the correct altitude offset, rotate the aneroid adjustment screw one complete revolution counterclockwise for each 1000 ft of correction required. Thus, to correct a 2000 ft offset requires rotating the aneroid adjustment screw approximately two turns counterclockwise.
- f. Torque the jam nut to 25-30 inch pounds after aneroid adjustment.

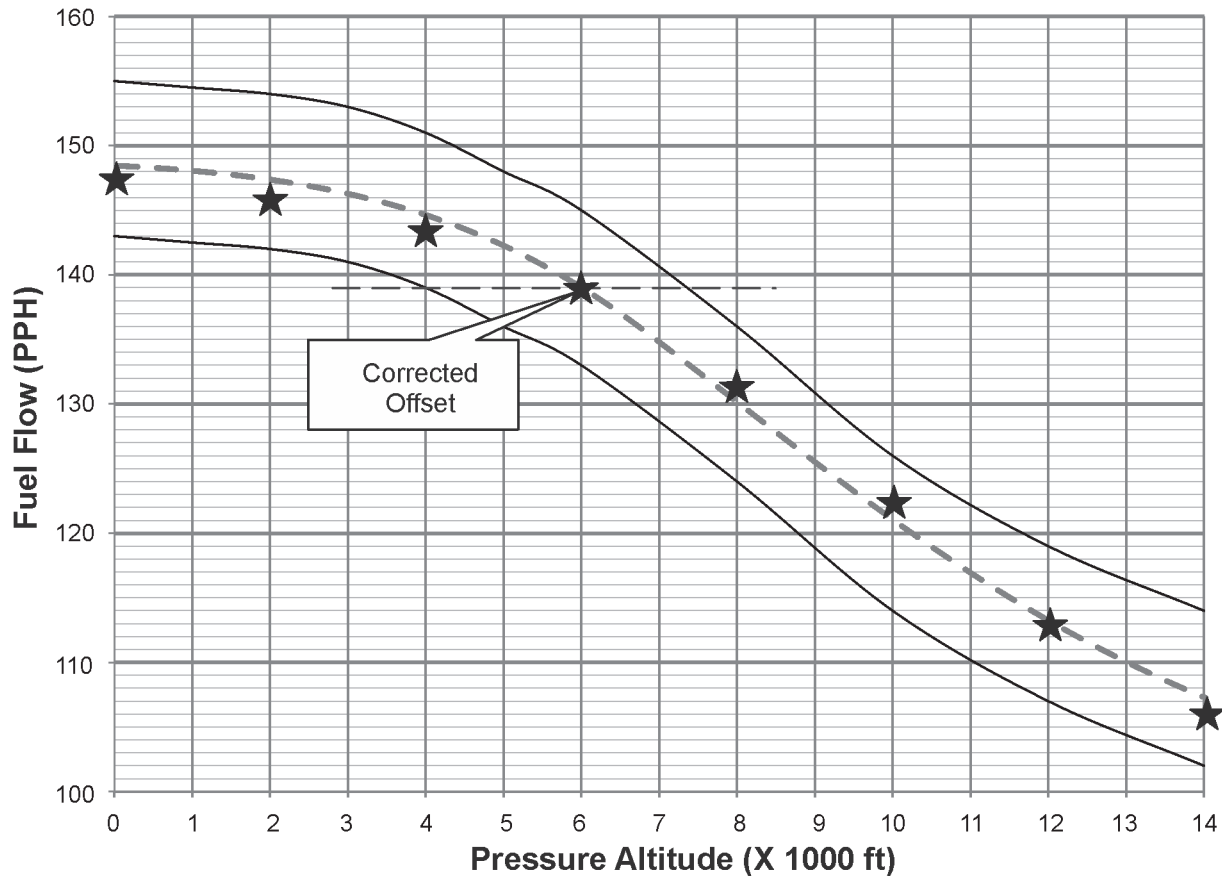

Figure 6-46. Altitude Leaning after Correction

7. Perform a complete ground run-up and verify the unmetered and metered pressures, idle mixture rise, and fuel flows are within the limits specified for the pressure altitude. If these parameters are not within the limits specified, make adjustments according to the instructions in Section 6-4.10.2 to achieve the specified values.
8. Once the adjustments are complete, remove the test equipment in accordance with the instructions in Section 6-4.7.6.
9. Perform a flight check according to instructions in Section 7-2.4.2.
10. Repeat procedures until the engine's fuel injection system meets all specifications.



6-4.10.2.5. Altitude Compensating Fuel System Auto-Leaning Schedules

**Table 6-11. IO-360-D/DB Engine Altitude Leaning Schedule
Full Throttle RPM, Full Rich Mixture @ 2800 RPM**

Pressure Altitude (Set Altimeter at 29.92 in. Hg.)	Fuel Flow (lbs/hr)		Fuel Flow (gals/hr)		Metered Fuel Pressure PSID	
	Min.	Max.	Min.	Max.	Min.	Max.
Sea Level	102.9	112.9	17.5	19.2	16.0	18.8
1,000	98.4	108.4	16.8	18.5	15.0	17.8
2,000	94.1	104.1	16.0	17.7	14.1	16.8
3,000	90.0	100.0	15.3	17.0	13.3	15.9
4,000	86.1	96.1	14.7	16.4	12.6	15.1
5,000	82.3	92.3	14.0	15.7	11.9	14.4
6,000	78.8	88.8	13.4	15.1	11.3	13.7
8,000	72.2	82.2	12.3	14.0	10.2	12.5
10,000	66.4	76.4	11.3	13.0	9.3	11.5
12,000	61.3	71.3	10.4	12.1	8.6	10.7
14,000	56.9	66.9	9.7	11.4	8.0	10.0
16,000	53.3	63.3	9.1	10.8	7.5	9.5

Gasoline = 5.87 lbs per gallon @ 70° F.
IO-360-DB installed in T-41 aircraft, Refer to Cessna SL81-2, dated July 1981 for amplified instructions

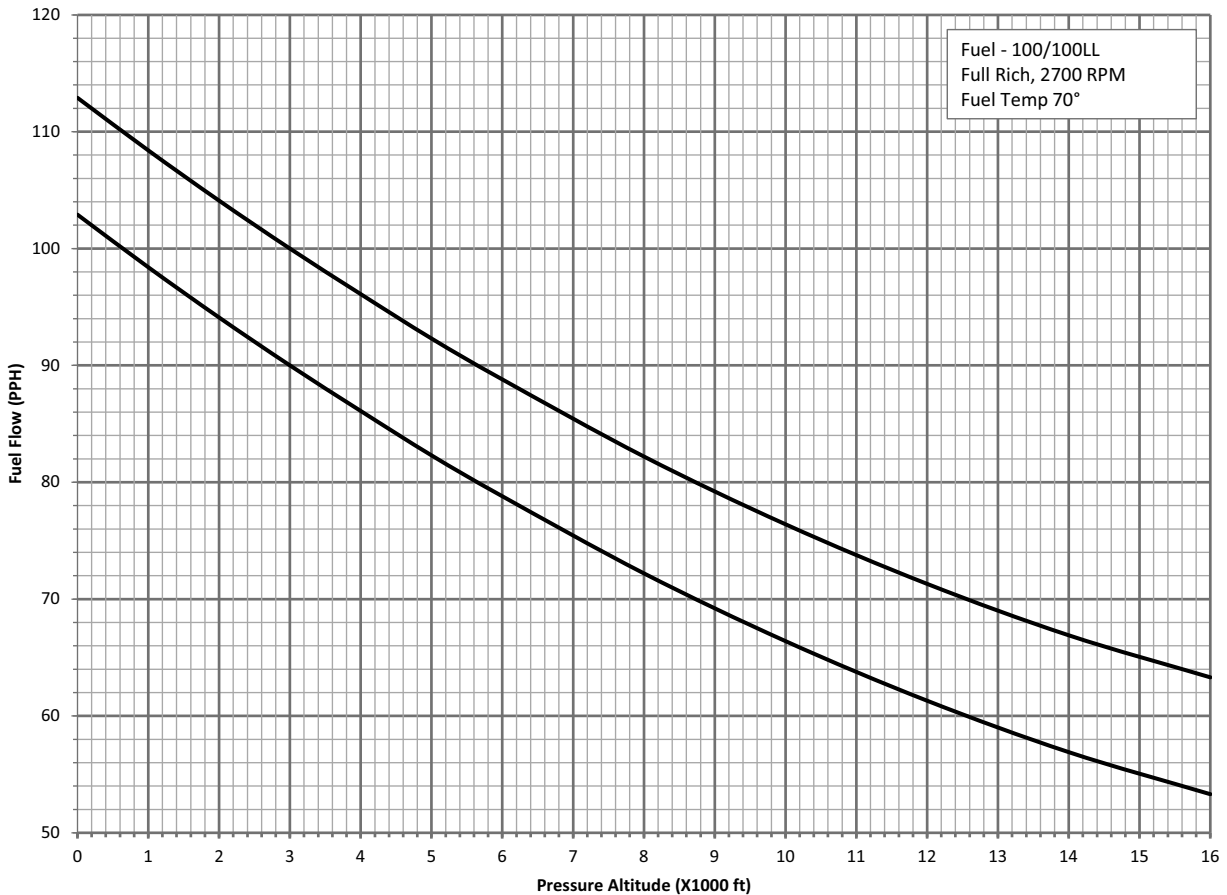

Figure 6-47. IO-360-D/DB Altitude Leaning Schedule



Table 6-12. IO-360-ES Engine Altitude Leaning Schedule
Full Throttle RPM, Full Rich Mixture @ 2800 RPM

Pressure Altitude (Set Altimeter at 29.92 in. Hg.)	Fuel Flow (lbs/hr)		Fuel Flow (gals/hr)		Metered Fuel Pressure PSID	
	Min.	Max.	Min.	Max.	Min.	Max.
Sea Level	100.0	107.0	17.0	18.1	14.3	16.5
1,000	97.7	103.7	16.6	17.7	13.9	15.8
2,000	93.7	99.7	16.0	17.0	13.1	14.9
3,000	90.3	96.3	15.4	16.4	12.3	14.1
4,000	87.3	93.3	14.9	15.9	11.7	13.6
5,000	85.0	91.0	14.5	15.5	11.5	13.2
6,000	83.3	89.3	14.2	15.2	11.1	12.8
8,000	80.0	86.0	13.6	14.7	10.6	12.2
10,000	77.3	83.3	13.2	14.2	10.1	11.8
12,000	74.4	80.4	12.7	13.7	9.6	11.2
14,000	71.3	77.3	12.1	13.2	9.2	10.7
16,000	69.3	75.3	11.8	12.8	8.9	10.3

Gasoline = 5.87 lbs per gallon @ 70° F.

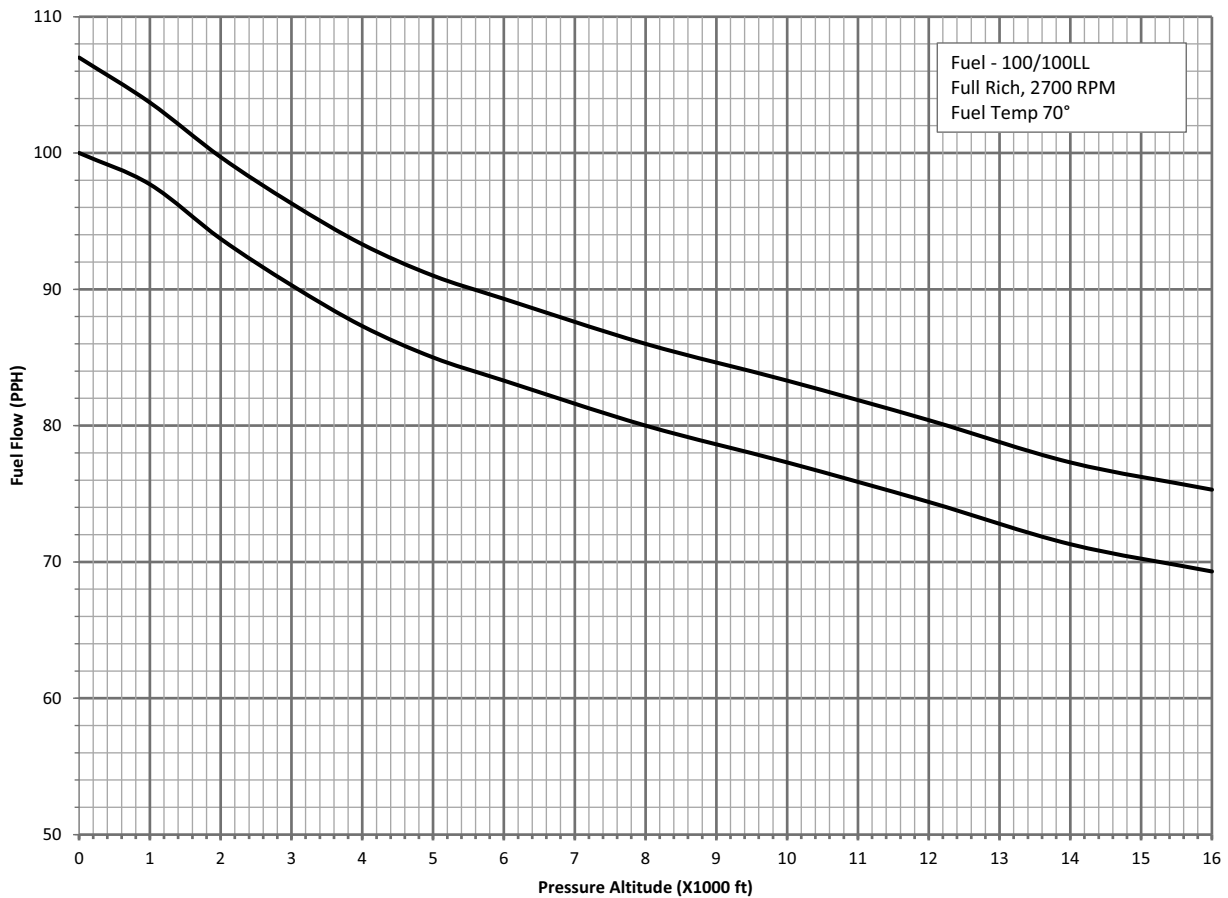

Figure 6-48. IO-360-ES Altitude Leaning Schedule



Table 6-13. IO-360-ES (Cirrus SR20) Engine Altitude Leaning Schedule
Full Throttle RPM, Full Rich Mixture @ 2700 RPM

Pressure Altitude (Set Altimeter at 29.92 in. Hg.)	Fuel Flow (lbs/hr)		Fuel Flow (gals/hr)		Metered Fuel Pressure PSID	
	Min.	Max.	Min.	Max.	Min.	Max.
Sea Level	96.0	102.0	16.4	17.4	13.8	15.5
1,000	94.5	99.7	16.0	17.0	13.3	15.0
2,000	89.5	95.7	15.3	16.3	12.5	14.2
3,000	86.3	92.3	14.7	15.7	11.9	13.5
4,000	83.3	89.3	14.2	15.2	11.4	13.0
5,000	81.0	87.0	13.8	14.8	11.0	12.5
6,000	79.3	85.3	13.5	14.5	10.7	12.2
8,000	76.0	82.0	12.9	14.0	10.2	11.7
10,000	73.3	79.3	12.5	13.5	9.7	11.2
12,000	70.4	76.4	12.0	13.0	9.3	10.7
14,000	67.3	73.3	11.5	12.5	8.8	10.2
16,000	65.3	71.3	11.1	12.1	8.6	9.9

Gasoline = 5.87 lbs per gallon @ 70° F.

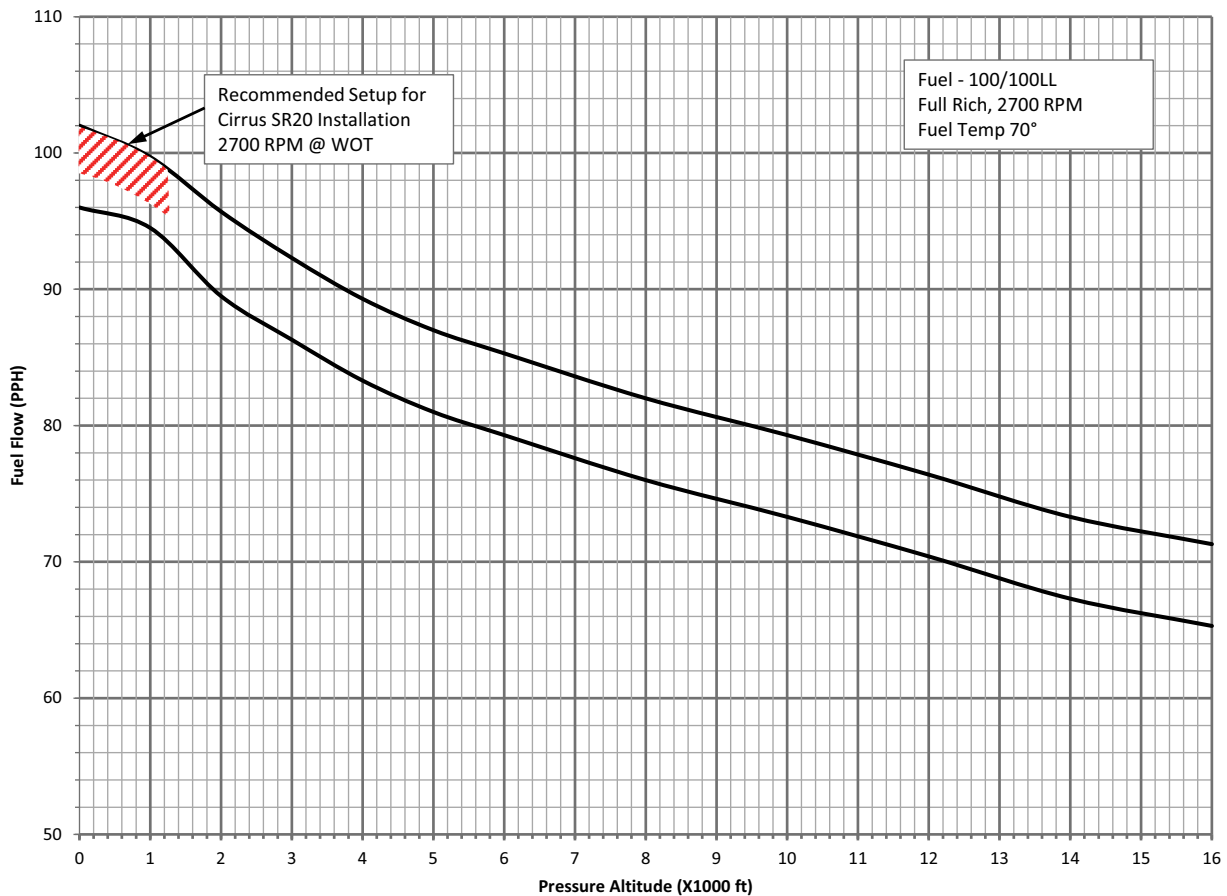

Figure 6-49. IO-360-ES in Cirrus SR20 Altitude Leaning Schedule



Table 6-14. IO-550-A Engine Altitude Leaning Schedule
Full Throttle RPM, Full Rich Mixture 300 BHP @ 2700 RPM

Pressure Altitude (Set Altimeter at 29.92 in. Hg.)	Fuel Flow (lbs/hr)		Fuel Flow (gals/hr)		Metered Fuel Pressure PSID	
	Min.	Max.	Min.	Max.	Min.	Max.
Sea Level	142	150	24.2	25.6	16.5	17.2
1,000	141	149	24.0	25.4	16.3	17.1
2,000	138	146	23.5	24.9	15.9	16.6
3,000	133	141	22.6	24.0	15.1	15.7
4,000	128	136	21.8	23.2	14.3	14.9
5,000	123	131	21.0	22.3	13.6	14.1
6,000	120	128	20.4	21.8	13.2	13.7
8,000	113	121	19.2	20.6	12.3	12.7
10,000	108	116	18.4	19.8	11.6	12.1
12,000	103	111	17.5	18.9	11.0	11.4
14,000	98	106	16.7	18.1	10.4	10.7

Gasoline = 5.87 lbs per gallon @ 70° F.

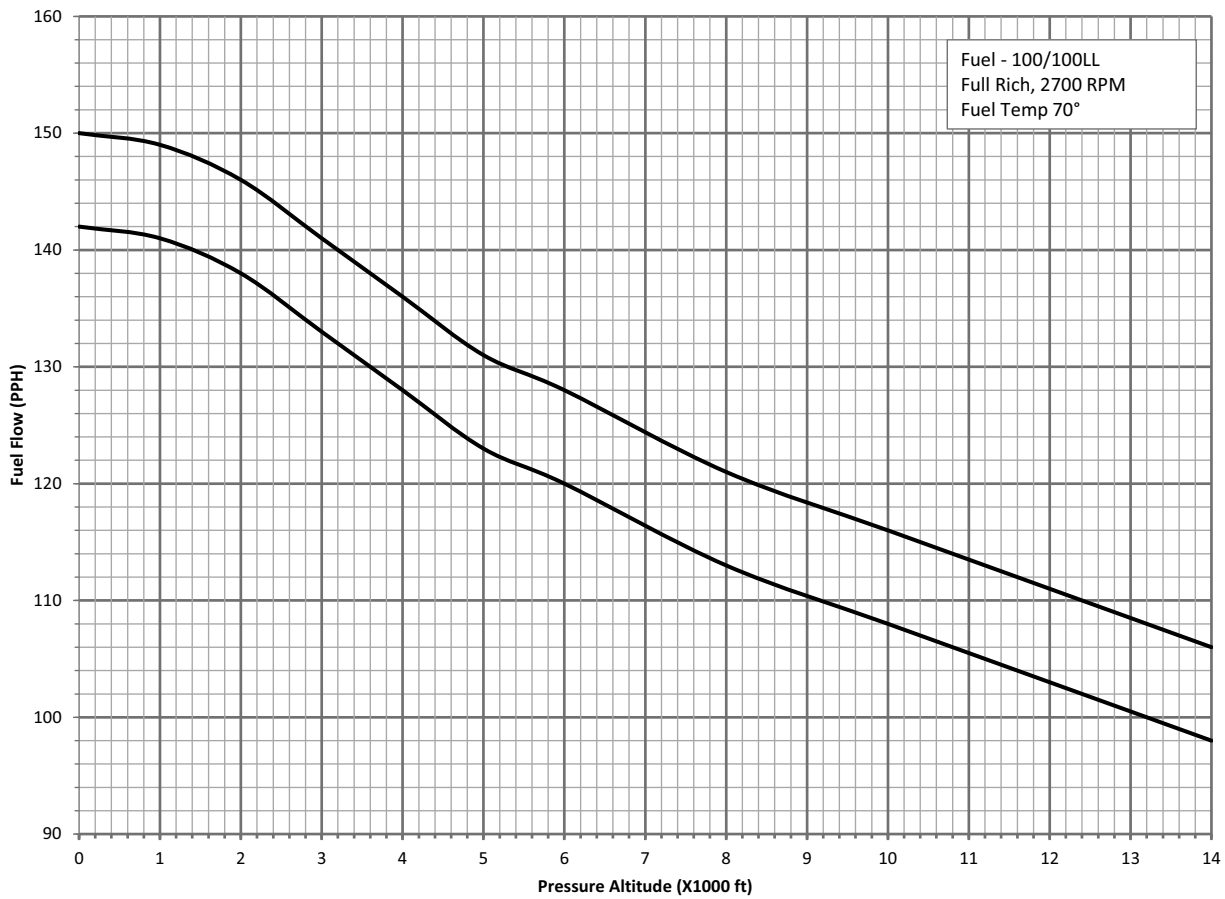

Figure 6-50. IO-550-A Altitude Leaning Schedule



**Table 6-15. IO-550-B Engine Altitude Leaning Schedule
Full Throttle RPM, Full Rich Mixture 300 BHP @ 2700 RPM**

Pressure Altitude (Set Altimeter at 29.92 in. Hg.)	Fuel Flow (lbs/hr)		Fuel Flow (gals/hr)		Metered Fuel Pressure PSID	
	Min.	Max.	Min.	Max.	Min.	Max.
Sea Level	146	156	24.9	26.6	17.2	18.3
1,000	145.5	155.5	24.8	26.5	17.1	18.2
2,000	145	155	24.7	26.4	17.0	18.1
3,000	144	154	24.5	26.3	16.9	17.9
4,000	142	152	24.2	25.9	16.5	17.5
5,000	139	149	23.7	25.4	16.1	17.0
6,000	135.5	145.5	23.1	24.8	15.5	16.5
8,000	127	137	21.6	23.3	14.2	15.1
10,000	117	127	19.9	21.6	12.8	13.6
12,000	110	120	18.7	20.4	11.9	12.6
14,000	105	115	17.9	19.6	11.3	11.9

Gasoline = 5.87 lbs per gallon @ 70° F.

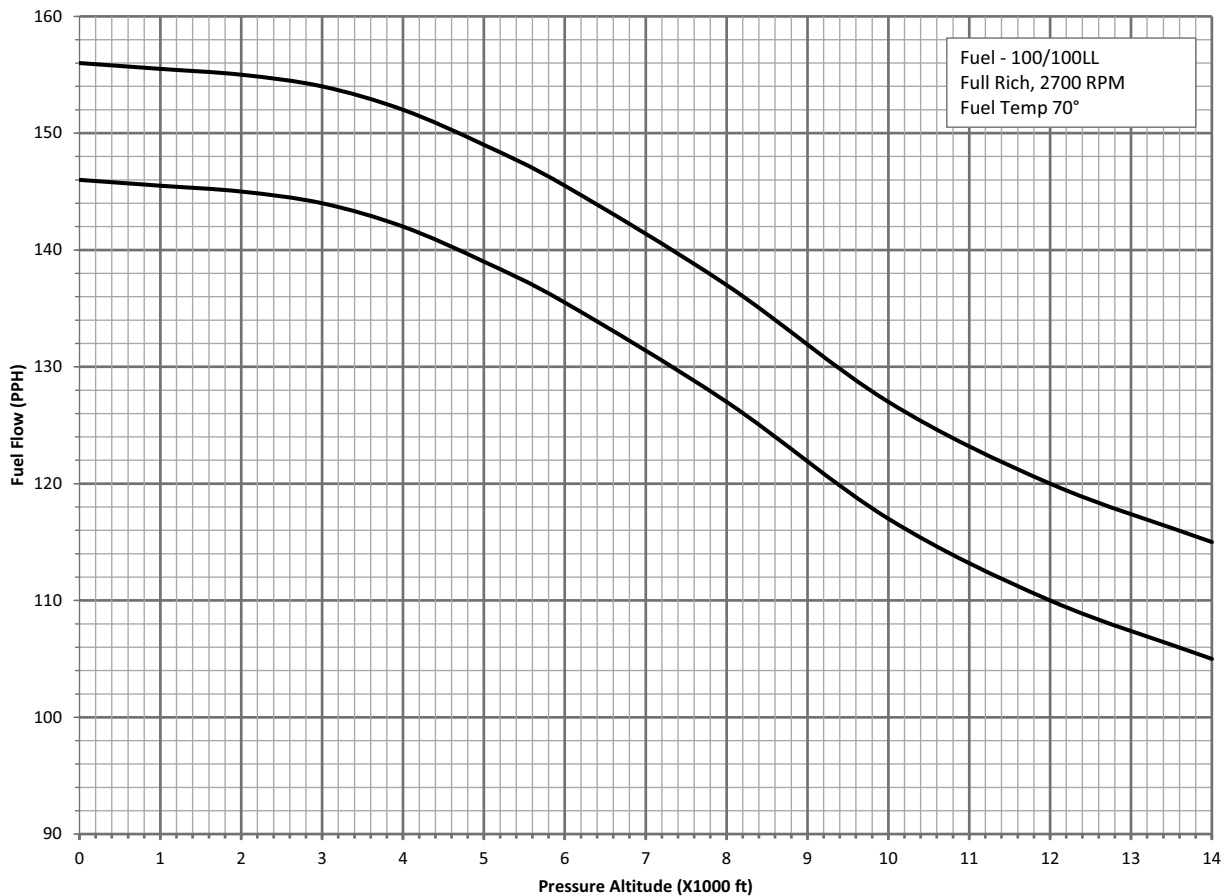

Figure 6-51. IO-550-B Altitude Leaning Schedule



Table 6-16. IO-550-C Engine Altitude Leaning Schedule
Full Throttle RPM, Full Rich Mixture 300 BHP @ 2700 RPM

Pressure Altitude (Set Altimeter at 29.92 in. Hg.)	Fuel Flow (lbs/hr)		Fuel Flow (gals/hr)		Metered Fuel Pressure PSID	
	Min.	Max.	Min.	Max.	Min.	Max.
Sea Level	152	160	25.9	27.2	18.2	18.9
1,000	151	159	25.7	27.1	18.0	18.7
2,000	148	156	25.2	26.6	17.5	18.2
3,000	143	151	24.4	25.7	16.7	17.4
4,000	138	146	23.5	24.9	15.9	16.5
5,000	134	142	22.8	24.2	15.3	15.9
6,000	130	138	22.1	23.5	14.7	15.3
8,000	123	131	21.0	22.3	13.6	14.1
10,000	118	126	20.1	21.5	12.9	13.4
12,000	113	121	19.3	20.6	12.3	12.7
14,000	108	116	18.4	19.8	11.7	12.1

Gasoline = 5.87 lbs per gallon @ 70° F.

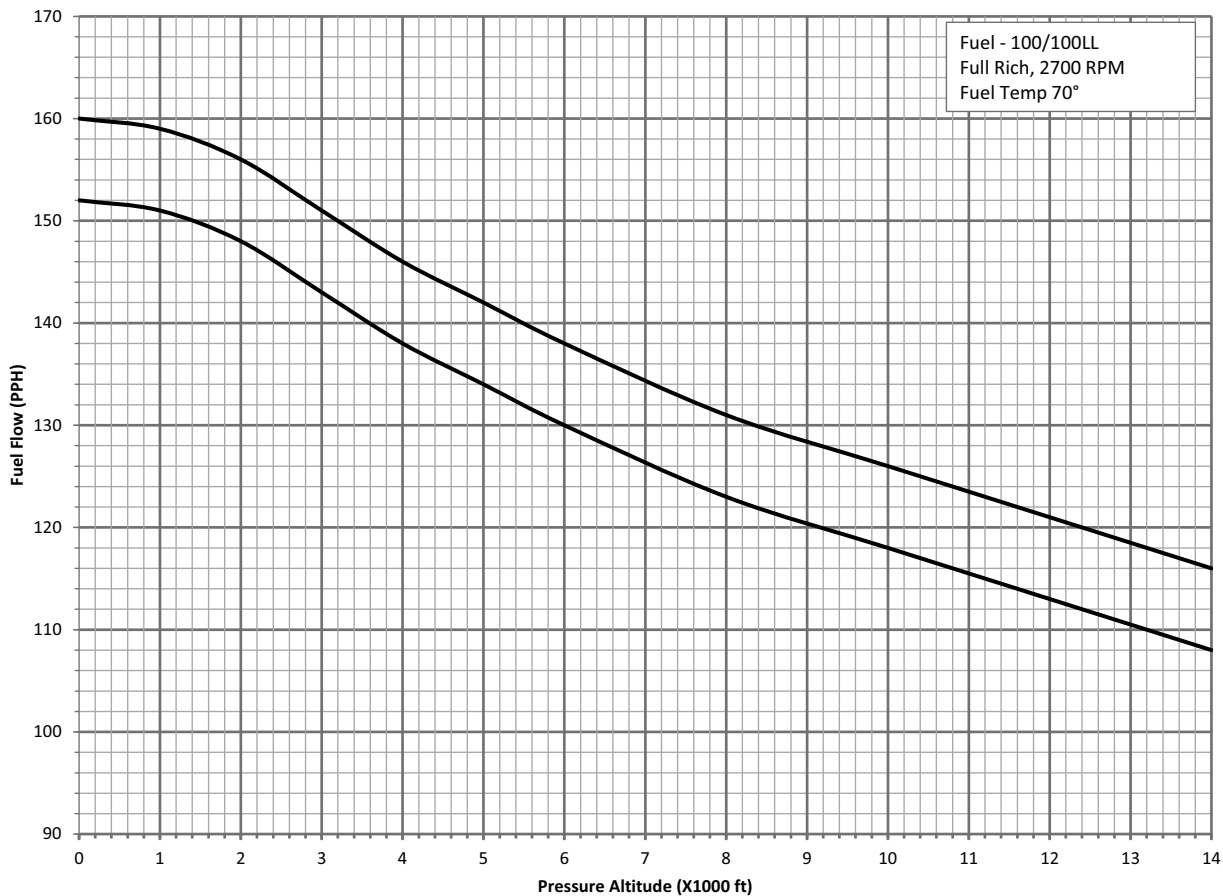

Figure 6-52. IO-550-C Altitude Leaning Schedule



**Table 6-17. IO-550-D, E, F, & L Engine Altitude Leaning Schedule
Full Throttle Static RPM, Full Rich Mixture 300 BHP @ 2700 RPM**

Pressure Altitude (Set Altimeter at 29.92 in. Hg.)	Fuel Flow (lbs/hr)		Fuel Flow (gals/hr)		Metered Fuel Pressure PSID	
	Min.	Max.	Min.	Max.	Min.	Max.
Sea Level	143	155	24.4	26.4	17.2	20.0
1,000	142.5	154.5	24.3	26.3	17.1	19.9
2,000	142	154	24.2	26.2	17.0	19.8
3,000	141	153	24.0	26.1	16.9	19.6
4,000	139	151	23.7	25.7	16.5	19.2
5,000	136	148	23.2	25.2	16.0	18.7
6,000	133	145	22.6	24.7	15.5	18.2
8,000	124	136	21.1	23.2	14.0	16.6
10,000	114	126	19.4	21.5	12.5	15.0
12,000	107	119	18.2	20.3	11.5	13.9
14,000	102	114	17.4	19.4	10.8	13.1

Gasoline = 5.87 lbs per gallon @ 70° F.

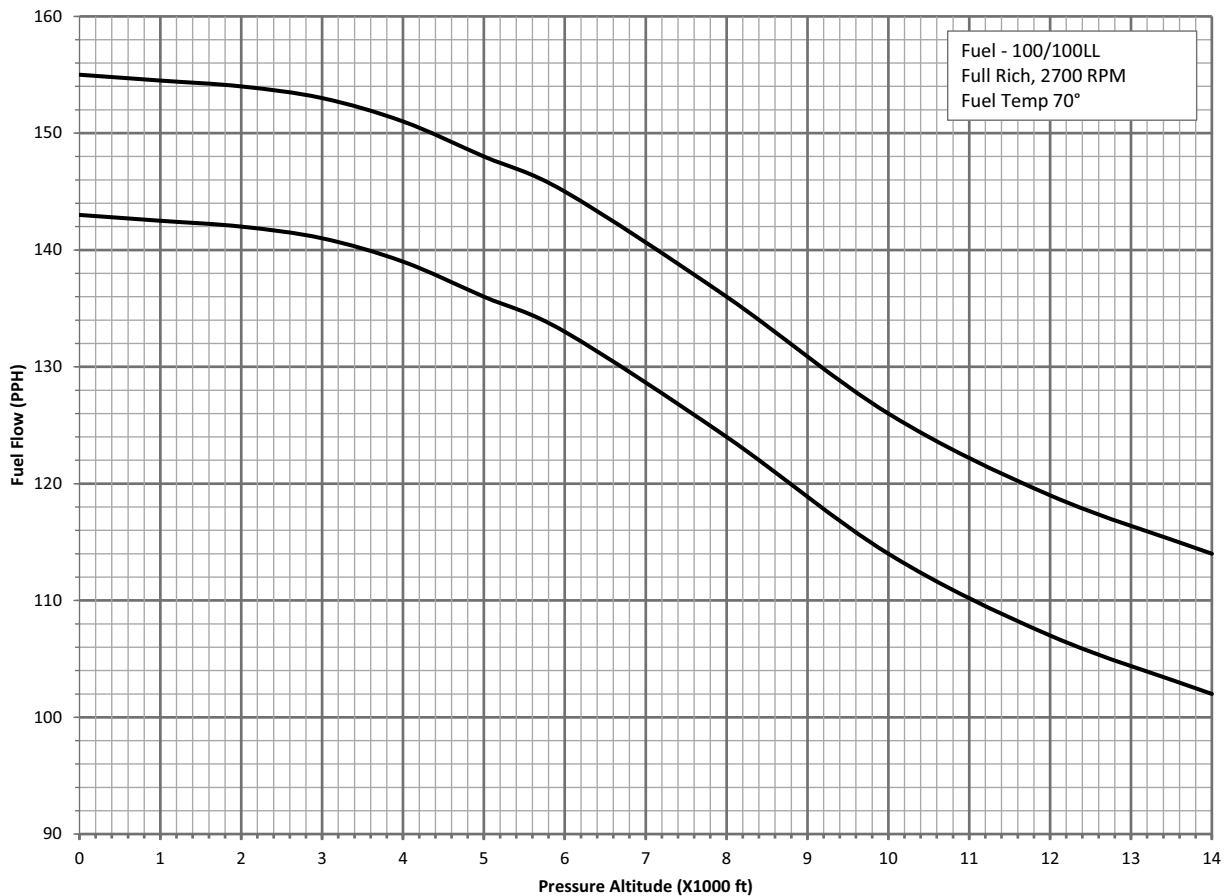

Figure 6-53. IO-55-D, E, F & L Altitude Leaning Schedule



6-4.10.3. Manifold Pressure Adjustment

Manifold pressure is based on ambient air pressure on naturally aspirated engines. Manifold pressure on turbocharged engines is determined by the turbocharger to throttle interface and varies by engine model. Consult the turbocharger and exhaust system description in the primary ICA for a description of system functionality.

Some turbocharger system configurations are delivered with the engine, others are coordinated with, developed by, and configuration controlled by the aircraft manufacturer. For systems not depicted in this manual, refer to the primary ICA or the Aircraft Maintenance Manual.

The following turbocharger and exhaust systems, or parts thereof, are provided by the aircraft manufacturer:

See Aircraft Maintenance Manual for the following Engine Models:

GTSIO-520-C, D, H, K, L, M, N;

TSIO-360-A, AB, B, BB, C, CB, D, DB, H, HB, and JB;

TSIO-470-B, C and D

TSIO-520-B, BB, C, D, DB, E, EB, G, H, J, JB, K, KB, M, N, NB, P, R, AE, AF, CE, and VB;

TSIO-550-C (select Cessna specifications)

TSIOL-550-A

6-4.10.3.1. Fixed Wastegate Adjustment

**Applicable Engines: TSIO-360-E, EB, F, FB, G, GB, KB, LB;
LTSIO-360-E, EB, KB**

Engine manifold pressure is controlled by a ground adjustable fixed wastegate on the exhaust bypass pipe at the turbocharger location. This adjustment is preset and only minor changes should be required.

Procedure

NOTE: Takeoff rated manifold pressure and RPM are obtained at approximately 40% throttle travel

1. Loosen jam nut on adjustment bolt.
2. For initial setting at installation or replacement: Screw the adjustment bolt (Figure 6-54) clockwise (*CW*) to the fully seated position. Turn the adjustment bolt counterclockwise (*CCW*) ten (10) turns and lock in position with the jam nut.
3. Run engine according to AFM/POH. Advance throttle to obtain rated manifold pressure. Make fine adjustments required to meet the manifold pressure setting for the engine model in Table 6-4, *CW* to increase, *CCW* to decrease.
4. Torque the jam nut on adjustment bolt after adjustments are complete. safety wire the adjustment bolt to the adjacent anchor point after the jam nut final torque.

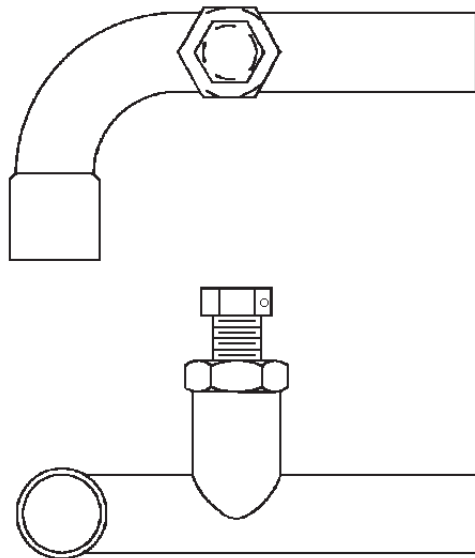

Figure 6-54. Fixed Wastegate (Typical)

5. Check critical altitude during Flight Check (Section 7-2.4.2); if adjustment is necessary:

NOTE: Take-off rated MP and RPM are obtained at approximately 40° throttle travel.

NOTE: Adjusting the exhaust bypass is extremely important. This setting determines Full Throttle manifold pressure and critical altitude and must be properly adjusted before the fuel system can be set up accurately.

NOTE: Rated manifold pressure for a given altitude should be achieved on take-off roll. If rated MAP cannot be obtained, check for exhaust leaks, turbocharger condition or calibration of overboost valve.

NOTE: To check actual critical altitude, the aircraft must be flown. Refer to Aircraft Service Manual for test flight procedures. If critical altitude is not correct and fixed wastegate is readjusted, the metered fuel flow must be rechecked and set to maximum power (full throttle) values.

6. Make adjustments, as necessary, to the fixed wastegate adjustment. Turning bolt clockwise (**CW**) increases critical altitude, turning bolt counter-clockwise (**CCW**) decreases critical altitude.

NOTE: One complete turn (360°) of the adjustment bolt changes the critical altitude by approximately 1000 feet.

7. Torque the jam nut on adjustment bolt after adjustments are complete. safety wire the adjustment bolt to the adjacent anchor point after the jam nut final torque.



6-4.10.3.2. Fixed Orifice Wastegate Adjustment

Applicable Engines: TSIO-520-T

The fixed orifice wastegate is a ground adjustable bypass valve located in the turbine exhaust bypass duct. The position of the fixed orifice wastegate valve remains constant throughout all modes of engine operation. An overboost pressure relief valve is used with the fixed orifice wastegate valve to bleed off upper deck pressure that exceeds the limits set by the aircraft manufacturer. Early Model TSIO-520-T engines use an exhaust system bypass valve similar to the one depicted in Figure 6-57, A. Current production engines use an exhaust system bypass valve similar to the one depicted in Figure 6-57, B. The bypass valve is installed in the exhaust system just forward and to the right of the turbocharger.

Procedure

1. Loosen jam nut on adjustment bolt.
2. If the installed exhaust system bypass resembles Figure 6-55, A:
 - a. Screw the adjustment bolt clockwise (*CW*) to the fully seated position. Turn the adjustment bolt counterclockwise (*CCW*) two turns and lock in position with the jam nut.
 - b. Run engine to check full throttle manifold pressure. Make fine adjustments required to meet the performance curve in the primary ICA, *CW* to increase, *CCW* to decrease.
3. If the installed exhaust system bypass resembles Figure 6-55, B:
 - a. Screw the adjustment bolt clockwise (*CW*) to the fully seated position. Turn the adjustment bolt counterclockwise (*CCW*) eight and one-half (8½) turns and lock in position with the jam nut.
 - b. Run engine to check full throttle manifold pressure. Make fine adjustments required to meet the performance curve in the primary ICA, *CW* to increase, *CCW* to decrease.
4. Torque the jam nut on adjustment bolt to Appendix B specifications and safety wire when complete.



Figure 6-55. Fixed Wastegate (TSIO-520-T) (Typical)

6-4.10.3.3. Sloped Controller Adjustment

**Applicable Engines: TSIO-520-BE;
TSIO-550-A, B, C, E, G, K, N
TSIOL-550-C**

CAUTION: Instructions in this section were verified on TSIO-550-C engine models. For all other engine models, consult the Aircraft Maintenance Manual before proceeding.

The sloped controller limits oil flow through the wastegate, which determines the position of the butterfly valve in the wastegate. Adjustment of the sloped controller may be required after an engine is installed, rebuilt, serviced, or overhauled, or sloped controller replacement.

Procedure

1. Orient the aircraft nose into the prevailing wind and run the engine at 1500 to 1800 RPM until the oil temperature is 160 to 180° F (71 to 82°C).
2. Using a handheld digital tachometer set the propeller controls according to the Section 6-4.7.1.
3. With the throttle in the FULL FORWARD position, set the intake manifold pressure according to the value in Section 6-4.7.1 for the engine model by turning the adjusting screw on the bottom of the slope controller (Figure 6-56) using a wide blade common screwdriver. Turning the screw clockwise (*CW*) increases manifold pressure, counter-clockwise (*CCW*) decreases manifold pressure.

NOTE: 1/8 turn of the adjusting screw=@1.0 inch Hg.

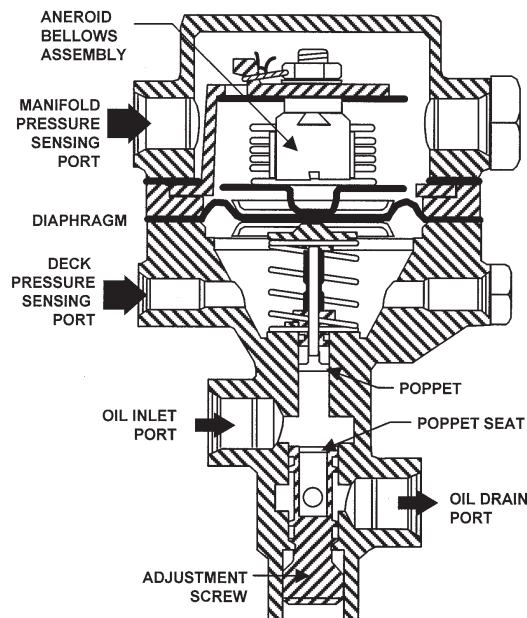

Figure 6-56. Sloped Controller



6-4.10.3.4. Variable Absolute Pressure Controller Adjustment

Applicable Engines: TSIO-360-MB, RB, SB; LTSIO-360-RB; TSIO-520-L, LB, N, NB, UB, and WB;

The Variable Absolute Pressure Controller (VAPC) limits oil flow through the wastegate, which determines the position of the butterfly valve in the wastegate. Adjustment of the VAPC may be required after an engine is installed, rebuilt, serviced, or overhauled or if the VAPC is replaced.

Procedure

1. Orient the aircraft nose into the prevailing wind and run the engine at 1500 to 1800 RPM until the oil temperature is 160 to 180° F (71 to 82°C).
2. Using a hand held digital tachometer, set the propeller controls according to Table 6-18.
3. With the throttle in the FULL FORWARD position, set the intake manifold pressure according to the value in Table 6-18 for the engine model by turning the HIGH SETING adjusting screw on the VAPC (Figure 6-57). Turning the screw clockwise (*CW*) decreases manifold pressure, counter-clockwise (*CCW*) increases manifold pressure.

NOTE: One complete turn (360°) of the adjusting screw=@1.0 inch Hg manifold pressure.

Table 6-18. VAPC Parameters

Parameter	TSIO-360-MB	L/TSIO-360-RB	TSIO-360-SB	TSIO-520-LB TSIO-520-NB	TSIO-520-UB	TSIO-520-WB
Propeller Controls	2700 RPM	2600 RPM	2600 RPM	2700 RPM	2700 RPM	2700 RPM
Rated Manifold Air Pressure (Full throttle @ sea level) ±0.2 in. Hg	36.0 in. Hg	38.0 in. Hg	39.0 in. Hg	38.0 in. Hg	36.0 in. Hg	39.5 in. Hg

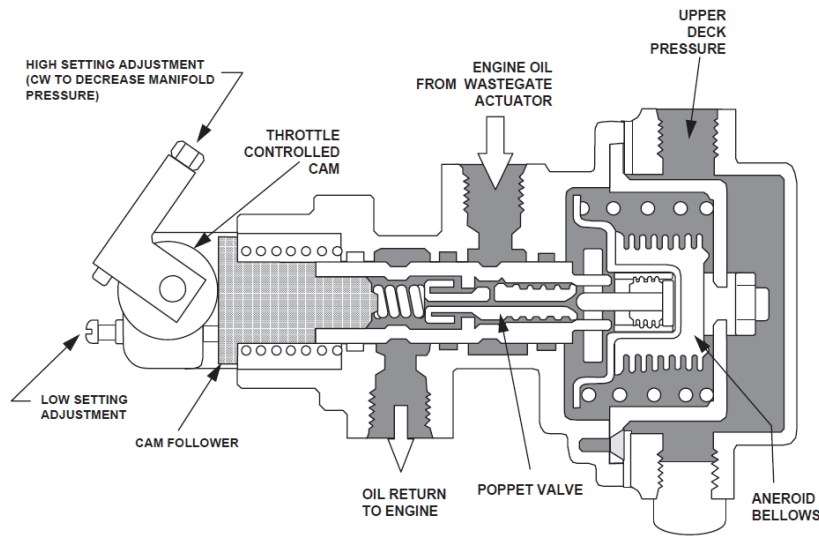

Figure 6-57. Variable Absolute Pressure Controller



Intentionally Left Blank



6-4.10.4. Belt Tension Check and Adjustment

Some Continental Motors engines may be fitted with an optional belt driven air conditioning compressor or belt driven alternator. Belt tension is critical to the function of these optional devices however, a new belt will stretch and tension will loosen during the break-in period after installation. Check the belt tension after the break-in period and during subsequent visual inspections.

6-4.10.4.1. Air Conditioning Compressor Drive Belt Tension Check and Adjustment

Applicable Engines: IO & L/TSIO-520; IO, IOF, TSIO & TSIOF-550 Permold Series Engines

Procedure

1. Inspect the drive belt for obvious signs of wear, nicks, or cracks; replace if necessary.
2. Check the belt tension at the point indicated in Figure 6-58 with a direct reading tension gauge (50 to 70 pounds) or measure belt deflection with a five pound load at the center of the longest belt span for 0.30 to 0.40 inches of deflection. If deflection is within tolerance, document the inspection results. To adjust belt tension, proceed to the next step.

NOTE: One full turn of the adjusting screw yields approximately 10 pounds change in tension.

3. Loosen the jam nut on the idler pulley. Tighten the adjusting bolt to increase tension, loosen the adjusting bolt reduce tension. When properly adjusted, secure the adjusting bolt with the jam nut and torque according to Appendix B specifications.

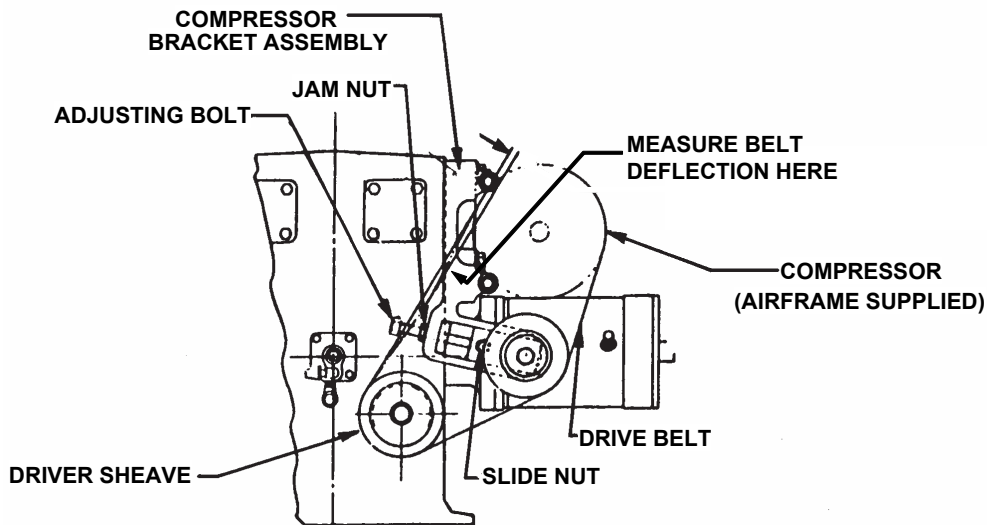

Figure 6-58. Air Conditioning Compressor Belt Tensioning



6-4.10.4.2. Air Conditioning Compressor Drive Belt Tension Check and Adjustment

Applicable Engines: IO and L/TSIO-360 Series Engines

Procedure

1. Inspect the drive belt for obvious signs of wear, nicks, or cracks; replace if necessary.
2. Check the belt tension at the center of the span between the drive sheave and the compressor with a Direct Reading Tension Gauge (Ideal Aviation BT-33-73FIA in Section 3) for 45 to 50 pounds (18 to 23 Kg) of belt tension. If tension is within tolerance, document the inspection results. To adjust belt tension, proceed to the next step.
3. To adjust belt tension for optional rear mounted compressor, do the following:
 - a. Loosen the adjustment bolt (Figure 6-59) (5) securing the compressor (10) to the top of the rear adjustment bracket (1).
 - b. Loosen the mounting bolt (4), washers (2), and nut (3) at the bottom of the rear adjustment bracket (1) to allow the compressor (10) to pivot.
 - c. Adjust the belt (8) tension and tighten the adjustment bolt (5). Torque the adjustment bolt (5) to Appendix B specifications.
 - d. Torque the mounting bolt (4) and nut (3) to Appendix B specifications.

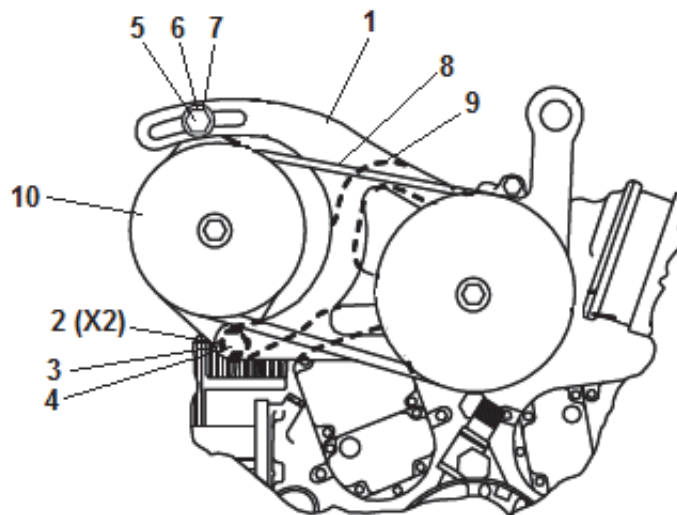

Figure 6-59. Optional Compressor Belt Tensioning (Typical)

1	Rear Bracket Assembly	4	Bolt	7	Washer	10	Compressor
2	Washer	5	Bolt	8	V-belt		
3	Nut	6	Lock Washer	9	Front Bracket Assembly		



6-4.10.4.3. Alternator Drive Belt Tension Check and Adjustment

Applicable Engines: IO & L/TSIO-520; IO, IOF, TSIO & TSIOF-550 Permold Series Engines with 70 amp alternator **Procedure**

1. Inspect the drive belt for obvious signs of wear, nicks, or cracks; replace if necessary.
2. Inspect the bracket, brace, and associated hardware for cracks or physical damage; replace if necessary.
3. Check the belt tension at the center of the span between the drive sheave and the alternator with a Direct Reading Tension Gauge (BT-33-73FIA) for 0.11 inch deflection with 6-8 pounds of belt tension applied. If deflection is within tolerance, document the inspection results. To adjust belt tension, proceed to the next step.
4. Loosen the upper bolt (Figure 6-60) (4), washer (2) and nut (3) securing the alternator (12) to the bracket (1).
5. Loosen the pivot screw (9) securing the alternator (12) to the adjustable brace (10).
6. Remove the safety wire and loosen the screw (5) at the bottom of the adjustable brace (10).
7. Adjust the belt tension until deflection is 0.11 inch with 6-8 pounds of belt tension applied and tighten the adjustment screw (5). Torque the adjustment screw to Appendix B specifications.
8. Torque the mounting bolt (3) and pivot screw (9) to Appendix B specifications. Safety wire the adjustment screw (5) to a nearby through bolt according to Appendix C specifications.

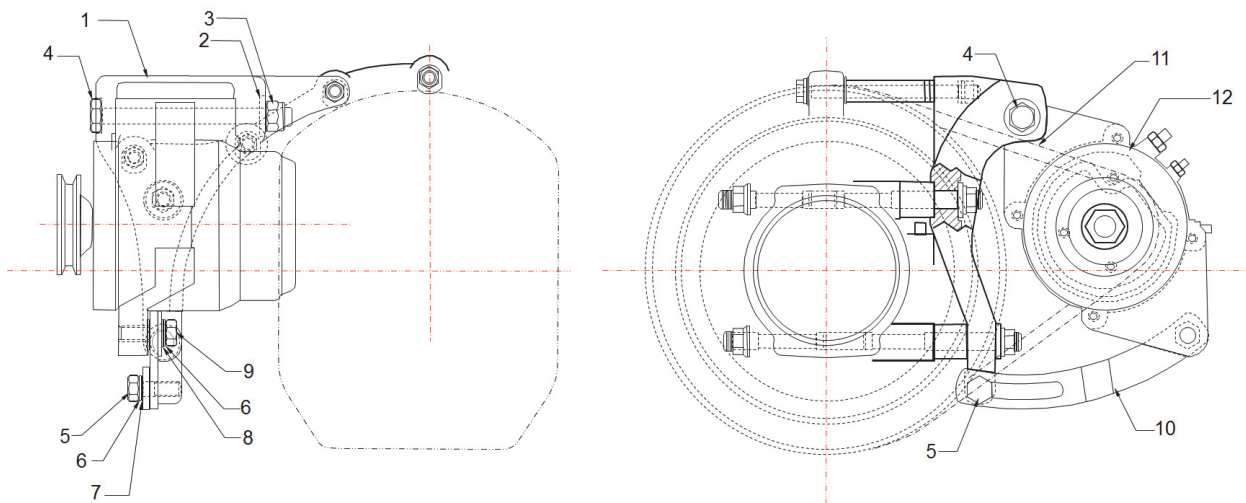

Figure 6-60. Alternator Belt Tensioning

1	Bracket Assembly	4	Bolt	7	Washer	10	Adjustment Brace
2	Washer	5	Bolt	8	Bracket	11	V-belt
3	Nut	6	Lock Washer	9	Bolt	12	Alternator Assembly



6-4.10.4.4. Alternator Drive Belt Tension Check and Adjustment

Applicable Engines: IO & L/TSIO-520; IO, IOF, TSIO & TSIOF-550 Permold Series Engines with 85 amp alternator

Procedure

1. Inspect the drive belt for obvious signs of wear, nicks, or cracks; replace if necessary.
2. Inspect the bracket, brace, and associated hardware for cracks or physical damage; replace if necessary.
3. Check the belt tension at the center of the span between the drive sheave and the alternator for 3.2 to 4.4 pounds of tension at 0.11 inch deflection or with a Direct Reading Tension Gauge (BT-33-73FIA) for 50-70 pounds of belt tension. If deflection is within tolerance, document the inspection results. To adjust belt tension, proceed to the next step.
4. Loosen the adjustment screw (Figure 6-61) (8) securing the alternator (10) to the adjustment brace (11).
5. Loosen the alternator mounting bolt (4) and nut (3) at the top of the bracket (1) to allow the alternator (10) to rotate.
6. Remove the safety wire and loosen the pivot screw (5) at the bottom of the alternator bracket (1).
7. Adjust the belt tension until deflection is 0.11 inch at 3.2 to 4.4 pounds of tension and tighten the adjustment screw (8). Torque the adjustment screw (8) to Appendix B specifications.
8. Torque the alternator mounting bolt (4) and pivot screw (5) to Appendix B specifications. Safety wire the pivot screw (5) to the hold drilled in the adjustment brace according to Appendix C instructions.

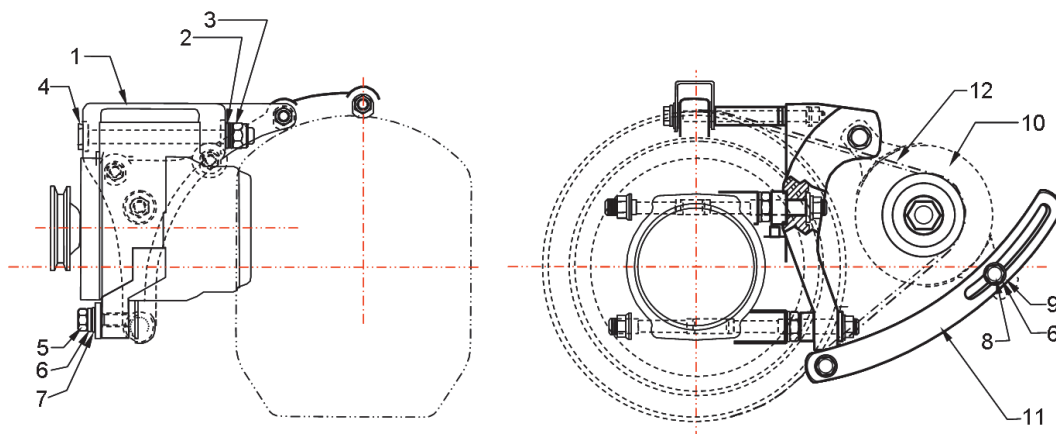

Figure 6-61. 85 Amp Alternator Belt Adjustment

1	Bracket Assembly	4	Bolt	7	Lock Washer	10	Alternator Assembly
2	Washer	5	Screw	8	Screw	11	Adjustment Brace
3	Nut	6	Lock Washer	9	Washer	12	V-belt



6-4.10.4.5. Alternator Drive Belt Tension Check and Adjustment

Applicable Engines: IO & L/TSIO-360 with front mount belt driven alternator

Procedure

1. Inspect the drive belt for obvious signs of wear, nicks, or cracks; replace if necessary.
2. Inspect the bracket, brace, and associated hardware for cracks or physical damage; replace if necessary.
3. Check the belt tension at the center of the span between the drive sheave and the alternator with a Direct Reading Tension Gauge (BT-33-73FIA) for 45-50 pounds of belt tension. If tension is within tolerance, document the inspection results.
4. To adjust belt tension, do the following:
 - a. Loosen the bolt (Figure 6-62)(5) securing the alternator (12) to the adjustment brace (10).
 - b. Loosen the pivot bolt (9) and lock nut (15) at the bottom of the bracket (1).
 - c. Loosen the mounting bolt (4), and nut (3) at the top of the bracket (1) to allow the alternator (12) to pivot.
 - d. Adjust the belt (11) tension and tighten the bolt (5). Torque the bolt (5) to Appendix B specifications.
 - e. Torque the mounting bolt (4), nut (3), lock nut (15) and pivot bolt (9) to Appendix B specifications.

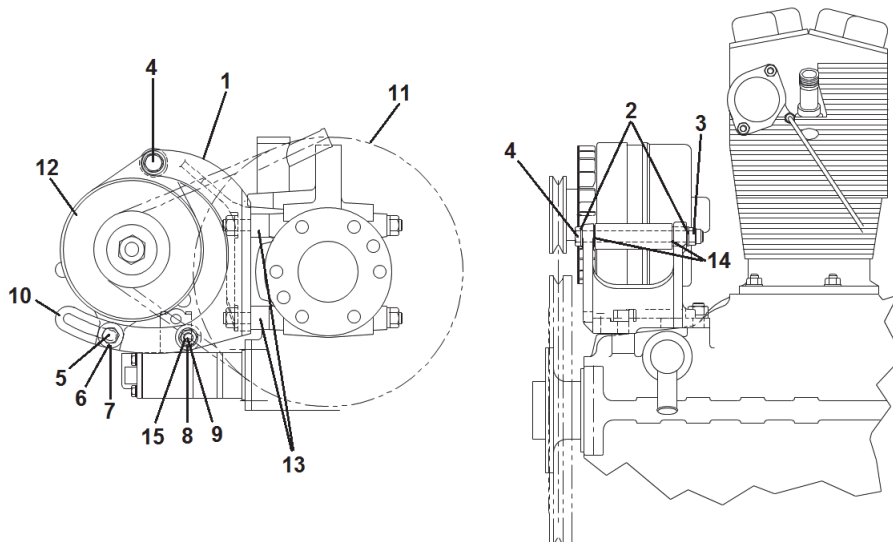

Figure 6-62. Front Mount Belt Driven Alternator

1	Bracket Assembly	5	Bolt	9	Bolt	13	Spacer
2	Washer	6	Lock Washer	10	Adjustment Brace	14	Washer
3	Nut	7	Washer	11	V-belt	15	Lock Nut
4	Bolt	8	Washer	12	Alternator		



6-4.10.4.6. Alternator Drive Belt Tension Check and Adjustment

Applicable Engines: IO & L/TSIO-360 with aft mount belt driven alternator

Procedure

1. Inspect the drive belt for obvious signs of wear, nicks, or cracks; replace if necessary.
2. Inspect the bracket, brace, and associated hardware for cracks or physical damage; replace if necessary.
3. Check the belt tension at the center of the span between the drive sheave and the alternator with a Direct Reading Tension Gauge (BT-33-73FIA) for 45-50 pounds of belt tension. If tension is within tolerance, document the inspection results.
4. To adjust belt tension, do the following:
 - a. Loosen the adjustment bolt (Figure 6-63)(5) securing the alternator (10) to the top of the rear adjustment bracket (1).
 - b. Loosen the mounting bolt (4), washers (2), and nut (3) at the bottom of the rear adjustment bracket (1) to allow the alternator (10) to pivot.
 - c. Adjust the belt (8) tension and tighten the adjustment bolt (5). Torque the adjustment bolt (5) to Appendix B specifications.
 - d. Torque the mounting bolt (4) and nut (3) to Appendix B specifications

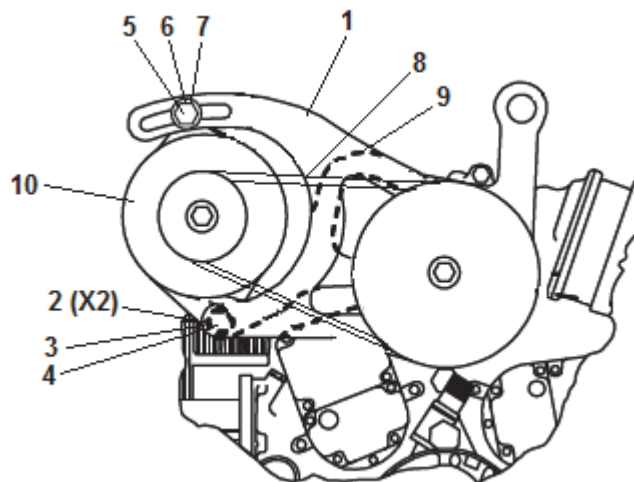

Figure 6-63. Aft Mounted Alternator Belt Tension Adjustment

1	Rear Bracket Assembly	4	Bolt	7	Washer	10	Alternator
2	Washer	5	Bolt	8	V-belt		
3	Nut	6	Lock Washer	9	Front Bracket Assembly		



6-4.11. Cylinder Inspections

A complete cylinder inspection entails the tasks described in the respective sections Table 6-19 below. Performing all of the tasks in Table 6-19 ensures items that can affect cylinder operation have been inspected and verified for proper operation. Use a copy of the “Cylinder Inspection Checklist” on page 6-171 to record inspection progress and findings.

Table 6-19. Cylinder Inspection Tasks and References

Task¹	Section Reference
Cylinder visual inspection	Section 6-4.11.1
Check cylinder differential pressure	Section 6-4.11.2
Inspect engine cylinders with borescope	Section 6-4.11.3
Inspect cylinder to crankcase mounting deck	Section 6-4.11.4
Inspect baffles	Section 6-4.11.5
Inspect cowling	Section 6-4.11.6

1. All tasks in this table must be performed for a complete cylinder inspection.

In addition to the instructions contained in this section, reference the following Service Documents to determine compliance requirements, based on engine model applicability.

Table 6-20. Additional Cylinder Service Document References

Document Number	Title
M92-8	Application of 4 -1/16 inch Diameter Cylinder Assemblies
M92-6	Rocker Shaft Retention Improvement for Inclined Valve Cylinder
M92-4	IO & L/T/SIO-360 Rocker Shaft Stud Inspection
M91-7	Cylinder Barrel Ultrasonic Inspection
M91-6	Cylinder Barrel Inspection
M73-13	Rocker Shaft Bosses
M73-2	Cylinder, Non - H FAA AD #72-20-02



6-4.11.1. Cylinder Visual Inspection

Procedure

1. Remove the engine compartment cowling according to the aircraft manufacturer's instructions and perform steps 2 & 3 without cleaning the engine.
2. Inspect the cylinder barrel power stroke areas (Figure 6-64) with an inspection mirror and light for cracks, sharp indentations, chafing, damage or pitting. Repair discrepancies according to instructions in the primary ICA. The power stroke areas include the:
 - Twelve o'clock area on the first six fins below the head on the 1-3-5 side of the engine as mounted on the crankcase.
 - Six o'clock area on the first six fins below the head on the 2-4-6 side of the engine as mounted on the crankcase.
3. Inspect the external surfaces of the cylinder head including the fins, intake and exhaust ports, top and bottom spark plug bosses and fuel nozzle bosses for cracks, exhaust flange leakage or any signs of oil, fuel, or soot leakage indicating the cylinder or the head-to-barrel junction structural integrity has been breached. ***For liquid cooled cylinder only:*** Inspect cylinder head cooling jackets for coolant leaks.

NOTE: If discrepancies are noted during the visual inspection, perform a "Differential Pressure Test" according to instructions in Section 6-4.11.2 and a "Cylinder Borescope Inspection" according to instructions in Section 6-4.11.3.

4. Thoroughly clean the exterior of the engine according to instructions in Chapter 12 and repeat steps 2 & 3.

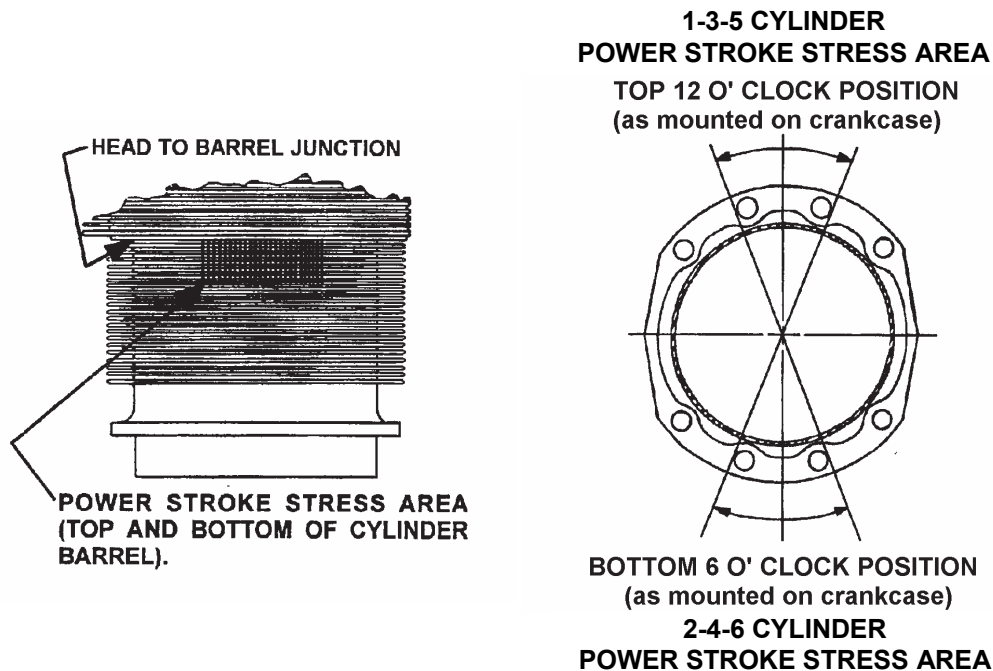

Figure 6-64. Cylinder Power Stroke Areas



6-4.11.2. Differential Pressure Test

Purpose

The Cylinder Differential Pressure Test is a nondestructive method of determining the internal condition of cylinders and cylinder components. As with any test or inspection, the Cylinder Differential Pressure Test has certain limitations that may necessitate its use in conjunction with other non-invasive inspections. The Cylinder Differential Pressure Test identifies leaks and the source of leaks, with the engine under static conditions (not running), using a regulated 80 psi pressure source. The Cylinder Borescope Inspection (Section 6-4.11.3) is used to assess the physical condition of the combustion chamber. Continental Motors requires a borescope inspection to be performed in conjunction with the Differential Pressure Test. Marginal or unsatisfactory results of the Cylinder Differential Pressure Test or Cylinder Borescope inspections may indicate the need to perform additional inspections.

NOTE: The static leak check does not relate directly to cylinder pressures developed during actual engine operations.

Monitor and record engine oil consumption, the appearance or color of the engine oil and any visual indications of high crankcase pressure (combustion blow-by) such as an oily, wet area on the aircraft belly or lower wing surface.

NOTE: Prior to performing the cylinder differential pressure test, determine the baseline master orifice calibrated pressure reading according to instructions in Section 6-4.11.2.1.

Excess cylinder wall or piston ring wear, broken piston rings and burned valves exhibit additional symptoms that include, but are not limited to the following:

- Excessive cylinder barrel wear and/or piston ring wear:
 - Elevated crankcase pressure; see “Excess Crankcase Pressure” in Section 8-9.1.
 - Sudden increased oil consumption (based on trend monitoring)
 - Oil discolored within first 10 hours after an oil change
- Broken piston rings:
 - Scored, grooved cylinder wall, evident via a borescope inspection
 - Abnormal debris in oil filter or oil screen
- Burned valves:
 - Extremely low cylinder differential pressure test results
 - Usually evident during borescope inspection.

Many variables affect Differential Pressure Test results, such as:

- Abnormal amounts of oil in the cylinder
- Engine temperature and cylinder temperature uniformity
- Test equipment accuracy
- Capacity and quality of the compressed air source
- Techniques used by the technician when performing the test



Frequency

Perform the differential pressure test:

- During 100-hour or Annual inspections
- If excessive oil consumption or blow-by is suspected
- If the cylinder exhibits signs of accelerated wear

Test Equipment

- Dry, oil-free compressed air source capable of providing a minimum line pressure of 125 P.S.I. with a minimum flow capability of 15 Cubic Feet per Minute (CFM).

NOTE: Master Orifice Tool (Part No. 646953A) is no longer available. Without the Master Orifice Tool, the Model E2A Differential Pressure Tester is not a valid test equipment option; the Model E2M Differential Pressure Tester must be used. If the facility performing the repairs is in possession of both a Model E2A Differential Pressure Tester and the Master Orifice Tool, the shop may continue to use them as alternatives to the Model E2M Differential Pressure Tester. Instructions in this manual apply only to the Model E2M Differential Pressure Tester.

The Eastern Technology web site (eastertech.com) indicates a Model E2M-1000, with a 0.060 Master Orifice should be used on cylinders with a bore greater than 5.0 inches however, approved type certificate data pertaining to engines in this manual were approved by the FAA using a Model E2M Differential Pressure Tester with a 0.040 inch Master Orifice.

- Eastern Technology Corporation Model E2M (Figure 6-65) Cylinder Differential Pressure Tester. This Differential Pressure Tester incorporates a 0.040 Master Orifice Tool.

WARNING

Differential Pressure Test equipment must be calibrated annually. Failure to properly maintain and calibrate the Differential Pressure Test equipment may result in misleading or erroneous Differential Pressure Test readings.

Perform the “Differential Pressure Tester Setup” instructions in Section 6-4.11.2.1 to calibrate the test equipment prior to conducting the Cylinder Differential Pressure Test. Perform the Cylinder Differential Pressure Test as soon as possible after the aircraft has returned from flight. If the aircraft cannot be flown prior to performing the Cylinder Differential Pressure Test, operate it on the ground, with the cowling installed until a minimum of 300 to 350°F (149 to 177°C) is observed on the aircraft cylinder head temperature (CHT) gauge.

WARNING

Shut the fuel supply OFF and ground the magnetos prior to performing the Differential Pressure Test to prevent accidental engine starts. Take necessary precautions to prevent accidental rotation of the propeller while performing this test. Differential pressure tests are best performed with two people, one to adjust the pressure regulator and one to hold the aircraft propeller.

The “Master Orifice” is a calibration standard that must be used prior to performing the Cylinder Differential Pressure Test. The Master Orifice establishes the acceptable cylinder pressure leakage limit for the test equipment being used and the atmospheric conditions at the time of the test. Record the acceptable cylinder pressure leakage limit, along with the individual cylinder readings in the engine logbook and on a copy of “Cylinder Inspection Checklist” on page 6-171.

6-4.11.2.1. Differential Pressure Tester E2M Setup

Perform this procedure to prepare the Model E2M Differential Pressure Tester (Figure 6-65) for use and establish the acceptable cylinder pressure leakage limit.

Procedure

1. Turn the Differential Pressure Tester pressure regulator valve OFF.
2. Position the Master Orifice Valve to the OFF position; handle is horizontal and directly over the OFF label.
3. Position the Slow Fill Valve (next to the pressure regulator) to the OFF position; handle is vertical, pointing down.
4. With the Slow Fill Valve in the OFF position, connect the air source to the Differential Pressure Tester male quick disconnect.

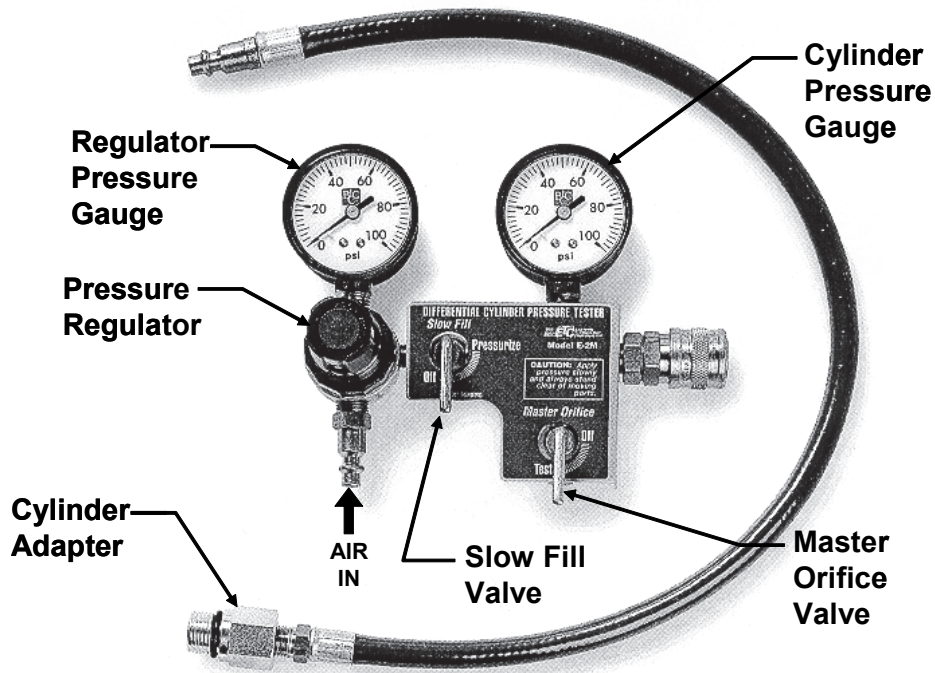

Figure 6-65. Model E2M Differential Pressure Tester

5. Adjust the pressure regulator for indicated 80 psi.
6. Set the Master Orifice Valve to the TEST position; handle is vertical, pointing down.
7. Turn the Slow Fill Valve to the PRESSURIZE position.



8. If necessary, adjust the pressure regulator to maintain an 80 psi indication on the regulator pressure gauge.
9. Record the cylinder pressure gauge indication on a copy of the Cylinder Inspection Checklist. This is the Acceptable Cylinder Pressure Leakage Limit.
10. Turn the Slow Fill Valve to the OFF position; handle is vertical, pointing down.
11. Turn the Master Orifice Valve to the OFF position; handle is horizontal, directly over the OFF label.
12. The Differential Pressure Tester is ready for use; proceed to Section 6-4.11.2.4, "Cylinder Differential Pressure Test."

6-4.11.2.2. Differential Pressure Tester Reliability Check

Keep the Differential Pressure Tester clean and check it periodically for accuracy:

1. Apply a line pressure of 100 to 120 psi; close the Slow Fill Valve.
2. Adjust the pressure regulator to 80 psi. The pressure in both gauges should stabilize with no leakage.

6-4.11.2.3. Leak Check

WARNING

Turn the Ignition Switch OFF and disconnect engine power before commencing maintenance or inspections. Do not stand or place equipment within the arc of the propeller.

Exercise care when opening the cylinder pressure valve, air pressure entering the cylinder may cause the crankshaft to rotate if the piston is not at bottom dead center.

This simple check will identify conditions undetectable by visual inspection that cannot be repaired. If the cylinder barrel to head junction is compromised, replace the cylinder; further inspection is unnecessary if the cylinder fails the leak check.

1. Have an assistant hold the propeller when applying air pressure to the cylinder to prevent propeller rotation.
2. With the compression tester connected, apply 5 psi oil free air to the cylinder.
3. Position the piston as close to bottom dead center on the compression stroke as possible, ensuring the intake valve remains closed to allow the cylinder to hold pressure.
4. Increase the pressure slowly to a maximum value of 80 psi. Saturate the exterior of the cylinder assembly with a mild non-alkaline soap and water solution.
5. Inspect the cylinder for leakage, indicated by an accumulation of air bubbles.
6. After cylinder inspection, relieve cylinder pressure and remove compression tester.
7. Repeat steps 1 through 5 for all cylinders. Rinse the cylinder thoroughly upon completion to remove the soap residue.



6-4.11.2.4. Cylinder Differential Pressure Test

Have an assistant hold the propeller when applying air pressure to the cylinder to prevent propeller rotation.

WARNING

Turn the Ignition Switch OFF and disconnect engine power before commencing maintenance or inspections. Do not stand or place equipment within the arc of the propeller.

Procedure

1. Perform the test as soon as possible after engine shut down to ensure the piston rings, cylinder walls, and other engine parts are well lubricated and at operating clearance.
2. Remove the most accessible spark plug from each cylinder. Identify the cylinder number and position of the removed spark plugs. Examine the spark plugs to aid in diagnosing engine and cylinder conditions. Refer to the spark plug manufacturer's technical data.
3. Turn the crankshaft by hand in the direction of rotation until the piston in the cylinder under test is positioned just before its compression stroke.
4. Install the cylinder adapter in the spark plug hole and connect the Differential Pressure Tester to the cylinder adapter (Figure 6-66).

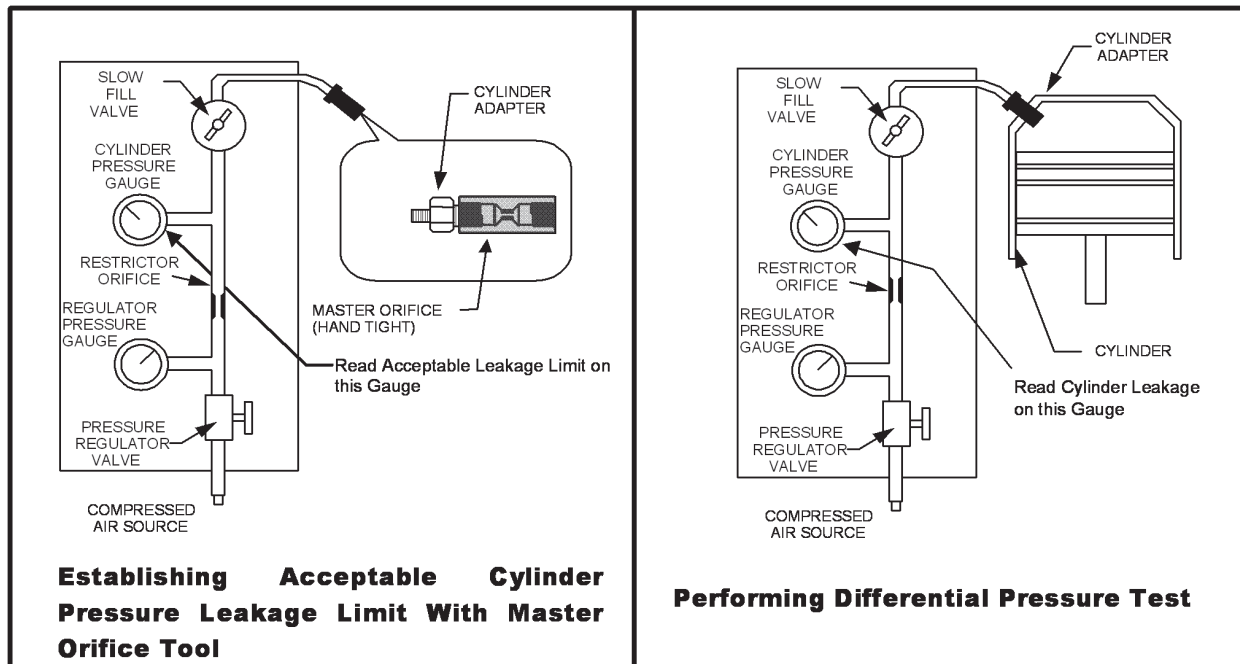

Figure 6-66. Differential Pressure Test Equipment Usage

NOTE: The Slow Fill Valve should be in the CLOSED position.



WARNING

Exercise care when opening the cylinder pressure valve, air pressure entering the cylinder may cause the crankshaft to rotate if the piston is not at bottom dead center.

5. Have an assistant secure the propeller to prevent rotation and slowly turn the Slow Fill Valve in the direction of the PRESSURIZE position to pressurize the cylinder to 20 psi.

NOTE: Some Continental Motors engines feature a lightweight starter which restricts turning the propeller in the opposite direction of normal rotation. For these engines, remove the starter prior to commencing the test or continue to turn the propeller in the normal direction of rotation to seek the TDC position with the highest pressure indication on the cylinder pressure gauge.

6. Continue turning the propeller in the normal direction of rotation, against the pressure until the piston reaches top dead center (TDC) indicated by a sudden decrease in the force required to turn the crankshaft. If the crankshaft is rotated too far, back up at least one-half revolution and start over again to eliminate the effect of valve train backlash and to keep the piston rings seated.

WARNING

The probability of air pressure in the cylinders turning the propeller during this procedure will be highest when the air pressure in the cylinder is raised to 80 psi in step 7. Stand outside the propeller arc with balanced footing while holding the propeller firmly to avoid injury.

7. With the piston at top dead center, open the Slow Fill Valve completely. Observe the regulator pressure gauge and adjust the pressure regulator, if necessary, for an 80 psi indication.
8. To ensure the piston rings are seated and the piston is square in the cylinder bore, move the propeller slightly back and forth with a rocking motion, while applying the regulated pressure of 80 psi, to obtain the highest indicated pressure reading on the cylinder pressure gauge. Adjust the pressure regulator, as necessary, to maintain a regulated pressure indication of 80 psi.
9. Record cylinder pressure gauge indication. The difference between indicated cylinder pressure and indicated regulator pressure is the amount of cylinder leakage. Record cylinder pressure indication as: $\frac{\text{(pressure reading)}}{80 \text{ psi}}$.

NOTE: Repeat steps 3 through 9 on each engine cylinder. Record Cylinder Differential Pressure Test results for each cylinder on a copy of the Cylinder Inspection Checklist.

10. Compare the recorded test results with Table 6-21 to determine what action, if any, is recommended.
11. Turn the Slow Fill Valve to the OFF position.



Engine Inspection and Service

12. Disconnect the test equipment from the cylinder and proceed to the “Cylinder Borescope Inspection” in Section 6-4.11.3.

Table 6-21. Differential Pressure Test Results

Air Discharge Source	Pressure Test Value	Symptoms and Observations	Recommended Action
Air discharge at oil filler/ crankcase breather.	Cylinder Differential Pressure Test reading above the acceptable cylinder pressure leakage limit.	Normal borescope indications. Oil consumption stable, no excessive oil discharge out engine breather	Continue engine in service. Repeat Differential Pressure Test at next 100-hour/annual inspection.
	Cylinder Differential Pressure Test reading below the acceptable cylinder pressure leakage limit.	Normal borescope indications. Oil consumption stable, no excessive oil discharge out engine breather.	Fly aircraft at Cruise Power setting ¹ and repeat Cylinder Differential Pressure Test.
	Cylinder Differential Pressure Test reading below the acceptable cylinder pressure leakage limit after re-test.	Not applicable	Remove cylinder for repair.
	Cylinder Differential Pressure Test reading above or below the acceptable cylinder pressure leakage limit	Oil consumption abnormal ² , with oil discharge out engine breather. Borescope inspection reveals heavy carbon deposits in combustion chamber and on piston crown with excessive oil puddling in cylinder barrel.	Remove cylinder for repair.
Little to no air discharge at oil filler/crankcase breather.	Cylinder Differential Pressure Test reading abnormally high	Oil consumption abnormal ² , with oil discharge out engine breather. Borescope inspection reveals heavy carbon deposits in combustion chamber and on piston crown with excessive oil puddling in cylinder barrel.	Remove cylinder for repair.



Table 6-21. Differential Pressure Test Results

Air Discharge Source	Pressure Test Value	Symptoms and Observations	Recommended Action
Air discharge into induction system	Cylinder Differential Pressure Test reading above the acceptable cylinder pressure leakage limit.	Normal cylinder borescope inspection results.	Continue engine in service.
	Cylinder Differential Pressure Test reading below the acceptable cylinder pressure leakage limit.	Normal cylinder borescope inspection results.	Fly aircraft at cruise power setting ¹ and repeat Cylinder Differential Pressure Test.
	Cylinder Differential Pressure Test reading below the acceptable cylinder pressure leakage limit after re-check.	Not Applicable	Remove cylinder for repair.
Air discharge into exhaust system	Cylinder Differential Pressure Test reading above the acceptable cylinder pressure leakage limit.	Normal cylinder borescope inspection results.	Continue engine in service.
	Cylinder Differential Pressure Test reading below the acceptable cylinder pressure leakage limit.	Normal cylinder borescope inspection results.	Fly aircraft at cruise power setting ¹ and repeat Cylinder Differential Pressure Test.
	Cylinder Differential Pressure Test reading below the acceptable cylinder pressure leakage limit after re-check.	Not Applicable	Remove cylinder for repair.
Air escaping at spark plug spot face	Cylinder Differential Pressure Test readings not applicable	Dye check of area reveals cracks.	Remove cylinder for replacement.
Air discharge at cylinder head to barrel juncture or between barrel fins	Cylinder Differential Pressure Test readings above the acceptable cylinder pressure leakage limit.	First cylinder head fin above cylinder barrel wet with oil or baked on oil residue.	Remove cylinder for replacement.

1. Fly the aircraft at cruise power setting between 65 and 75 percent power according to the Aircraft Flight Manual/Pilots Operating Handbook (AFM/POH) for a duration that will allow engine oil and temperatures to stabilize, or at least 45 minutes. Repeat the differential pressure test on the suspect cylinder.
2. A sudden increase in oil consumption from the established, normal trend.



6-4.11.3. Cylinder Borescope Inspection

Regular engine operation provides an oil coating for the cylinder and minimizes rust formation. New cylinders are particularly sensitive to rust formation if the engine is infrequently used or not properly preserved during storage.

NOTE: Ground operation of the engine is an unacceptable substitute for in-flight engine operation. Ground operation does not provide adequate cylinder cooling and introduces water and acids into the lubrication system.

Purpose

The cylinder borescope inspection provides a non-destructive method of visually examining the internal cylinder components and must be used in conjunction with the “Differential Pressure Test” to assess the condition of the valve, piston top, deposits, and the hone pattern on the cylinder barrel and identify abnormal wear patterns which can contribute to low differential pressure readings or increased oil consumption.

The cylinder wall hone pattern consists of engineered surface “scratches” which aid in ring seating by allowing the ring and wall surface to wear uniformly and provides a reservoir of oil for lubrication during ring travel. The cylinder walls and rings are designed to wear over the life of the engine, particularly in the power stroke area. The visible hone pattern in the upper portion of the bore may disappear during normal operation; and is not cause for cylinder replacement.

Required Equipment

- Mechanics tools
- Borescope

Frequency

- During 100-hour/Annual inspection
- If oil consumption is excessive
- After an engine overspeed incident
- Whenever an anomaly is suspected

WARNING

Turn the Ignition Switch OFF and disconnect engine electrical power before commencing maintenance or inspections. Confirm continuity between the magneto capacitor and aircraft ground to prevent accidental engine start during maintenance. Do not stand or place equipment within the arc of the propeller.

Take preventive measures to avoid burns when performing a Cylinder Borescope Inspection on a hot engine.

Procedure

1. Remove the engine cowling as necessary to gain access to the top spark plugs.
2. Remove the top spark plug from each cylinder.



3. Position the piston at bottom dead center on the power stroke. The exhaust valve will be open with the piston in this position.
4. Insert the borescope probe through the upper spark plug hole and inspect the internal surfaces of each cylinder, including the exhaust valve and exhaust valve seat.
5. Position the piston at bottom dead center at the end of the intake stroke.
6. Insert the borescope through the upper spark plug hole and inspect the intake valve and valve seat. Use Table 6-22 and Figure 6-67 through Figure 6-70 to interpret inspection findings.

Table 6-22. Borescope Inspection Objectives and Corrective Actions

Inspection Item	Objective	If Abnormality Noted
Combustion Chamber	Inspect: <ul style="list-style-type: none"> •Valve seat inserts for erosion, burning •Spark plug heli-coils for protrusion into combustion chamber •Heavy carbon deposits/presence of excessive oil 	Remove cylinder for repair
Exhaust Valve Face	Inspect for signs of leakage or damage indicated by: <ul style="list-style-type: none"> •Localized discoloration on the valve face circumference (Figure 6-68) •Minute cracks •Erosion (missing material) 	Repair or replace cylinder
Intake Valve Face	Inspect for signs of leakage or damage indicated by: <ul style="list-style-type: none"> •Localized discoloration on the valve face circumference •Erosion (missing material) 	Repair or replace cylinder
Cylinder Bore	Inspect exposed surface of bore for: <ul style="list-style-type: none"> •Heavy scoring/piston rub (Figure 6-71) •Piston pin rub (wide band pattern in horizontal plane at 3 o'clock and/or 9 o'clock position) 	Repair or replace cylinder
	Corrosion (Figure 6-70) ¹ Excessive oil in cylinder/heavy deposits of carbon in combustion chamber	Remove cylinder for repair
	Upper portion of cylinder bore has no visible hone pattern (Figure 6-72) and (Figure 6-73)	Normal indication for in service cylinders
Piston Head	Inspect for: <ul style="list-style-type: none"> •Piston crown for erosion, missing material •Visible damage from foreign debris 	Remove cylinder for repair

1. Remove cylinder for repair or replacement. Perform complete inspection of connecting rod bushing for correct installation and finishing.



Figure 6-67. Normal Combustion Chamber

Exhaust valve has reddish deposit in center with dark outer edge. Intake valve has light brown combustion deposits. Combustion chamber has light brown deposits.



Figure 6-68. Burned Exhaust Valve

Note the edge of valve face has lost all combustion residue with striations moving toward center of valve.



Figure 6-69. Phosphate-Coated Cylinder w/ Revised Hone Pattern

Phosphate coating provides increased corrosion protection during initial hours of engine operation.



Figure 6-70. Phosphated Cylinder Bore

Phosphate coating in valleys of the cylinder bore hone pattern. Light corrosion at top of cylinder bore, above piston ring travel limit in this area is normal.

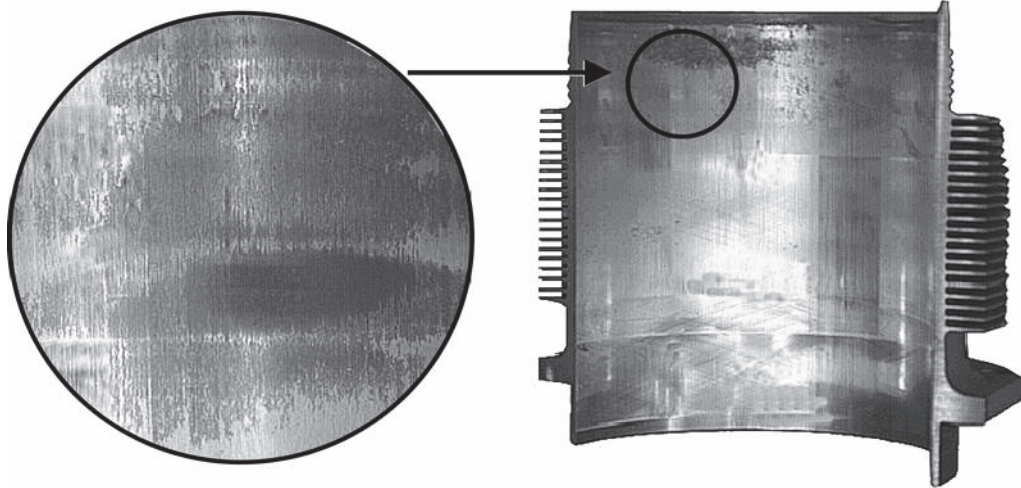

Figure 6-71. Cylinder Barrel Scoring and Piston Rub

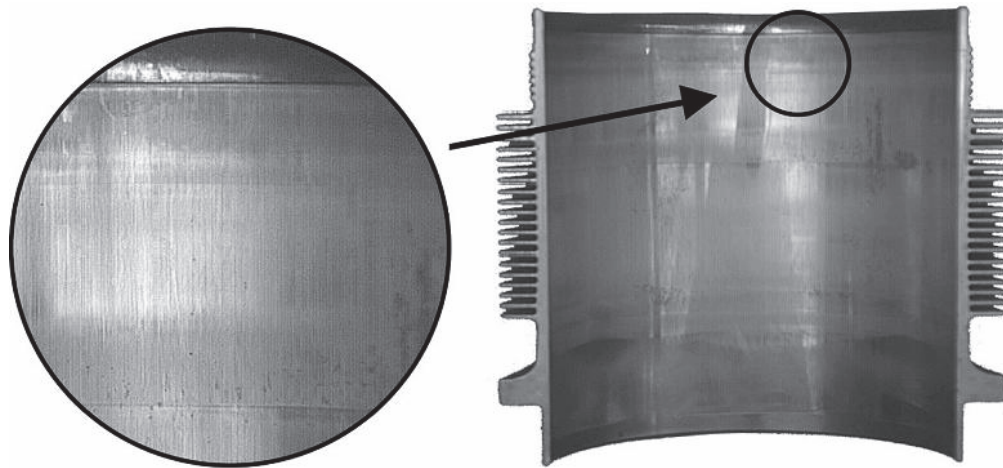

Figure 6-72. Typical Wear in Upper Ring Travel

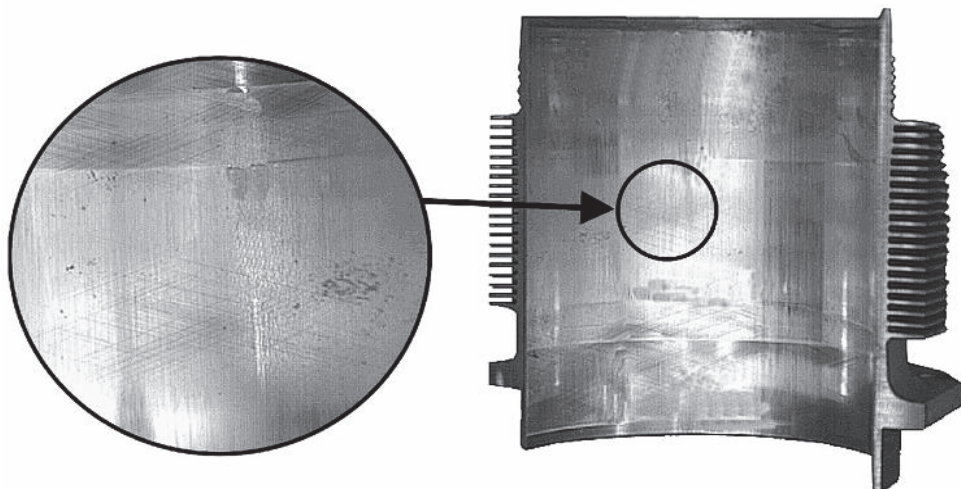

Figure 6-73. Typical Cylinder Wear



6-4.11.4. Cylinder to Crankcase Mounting Deck Inspection

Purpose

Proper cylinder torque requires a solid mounting surface. Foreign materials, such as grease or unauthorized sealants applied to the mounting base or flange will not allow proper fastener preload. Proper torque procedures are critical to engine operation.

Frequency

During 100-hour/Annual inspection

WARNING

Do not apply any form of sealant to the crankcase cylinder deck, chamfer, cylinder mounting flange, cylinder base O-ring, or cylinder fastener threads. The use of RTV, silicone, Gasket Maker or any other sealant on the areas listed above during engine assembly will cause a loss of cylinder deck stud or through-bolt torque. Subsequent loss of cylinder attachment load, loss of main bearing crush and/or fretting of the crankcase parting surfaces will occur. The result will be cylinder separation, main bearing movement, oil starvation and catastrophic engine failure. USE ONLY CLEAN 50 WEIGHT AVIATION ENGINE OIL ON SURFACES LISTED.

Procedure

Inspect the cylinder-to-crankcase mounting deck for evidence of silicone RTV sealant on the cylinder deck flange. If silicone RTV sealant or any other unauthorized sealant or adhesive is discovered, the engine must be completely disassembled, cleaned, inspected and assembled according to the overhaul instructions in the primary ICA.

1. Remove the engine from the aircraft according to instructions in Section 5-1.
2. Disassemble the engine according to the instructions in the primary ICA (**Section 1-1.1**).
3. Clean the engine components according to the instructions in the Chapter 12 of this manual.
4. Inspect the engine components according to the instructions in the primary ICA (**Ref: Section 1-1.1**).
5. Reassemble the engine according to instructions in the primary ICA (**Ref: Section 1-1.1**).
6. Perform the “Post-overhaul Testing” according to instructions in the primary ICA (**Ref: Section 1-1.1**).
7. Install the overhauled engine according to instruction in Section 5-2.



6-4.11.5. Baffle Inspection

Purpose

To prevent cylinder deterioration and verify baffles are properly fitted and installed. This inspection performed in concert with the cylinder inspection.

The heat transfer in piston engines requires efficient and reliable operation of cooling baffles to prevent rapid deterioration of the cylinders and other engine components. Verify the baffles are installed, intact, and positioned properly.

Frequency

During 100-hour/Annual inspection or whenever the cowling is removed

Procedure

1. Check the following for deterioration, wear, correct position, and proper contact with the cowl. Figure 6-74 through Figure 6-77 show improperly positioned baffle seals.
2. Repair or replace worn or distorted baffles in accordance with the aircraft manufacturer or Supplemental Type Certificate (STC) holder's information.
3. Check and adjust inter-cylinder baffles to ensure a tight fit.
4. Inspect for holes and cracks that would allow cooling airflow to be wasted. Seal any cracks or holes by applying a non-corrosive silicone adhesive/sealant. Consult the aircraft manufacturer for application instructions. Baffle conditions shown in Figure 6-78 shows air gaps that lead to inadequate cooling airflow. Figure 6-79 and Figure 6-80 show evidence of cooling air loss at the baffle seals.
5. Check the integrity of all cooling ducts, heater ducts, etc. and repair as necessary.

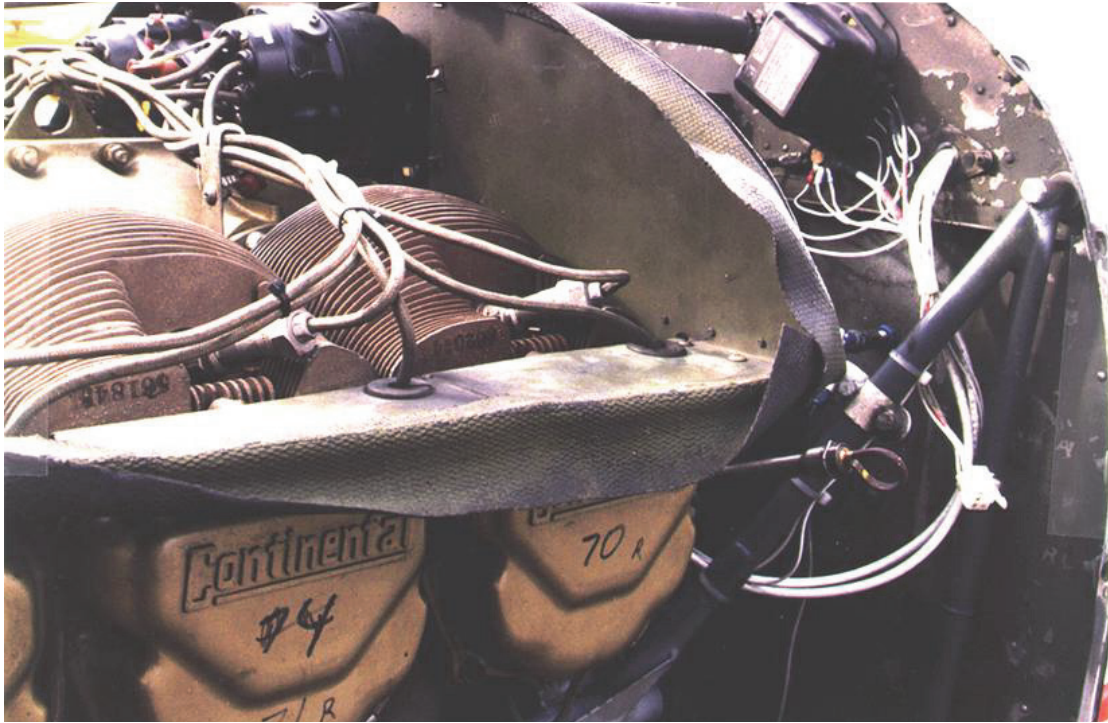

Figure 6-74. Improperly Positioned Baffle Seals

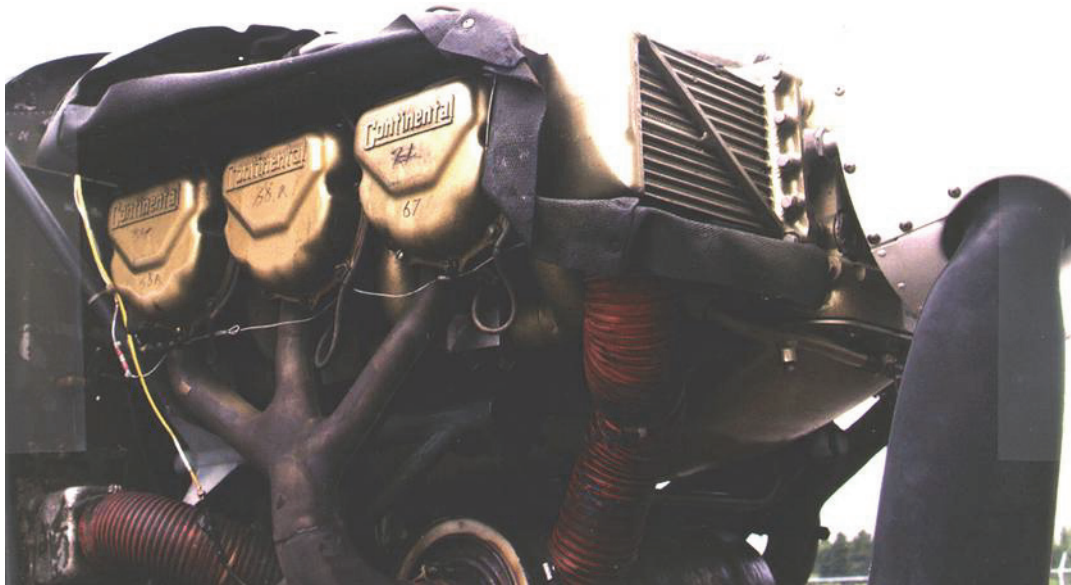

Figure 6-75. Improperly Positioned Baffle Seals

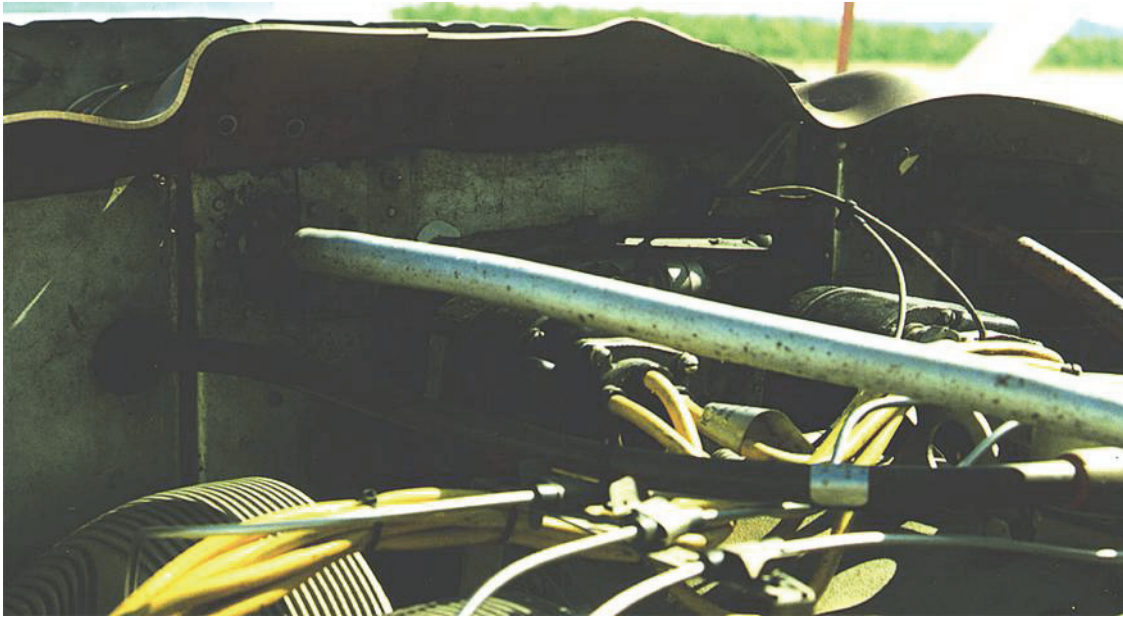

Figure 6-76. Improperly Positioned Aft and Side Peripheral Baffle Seals

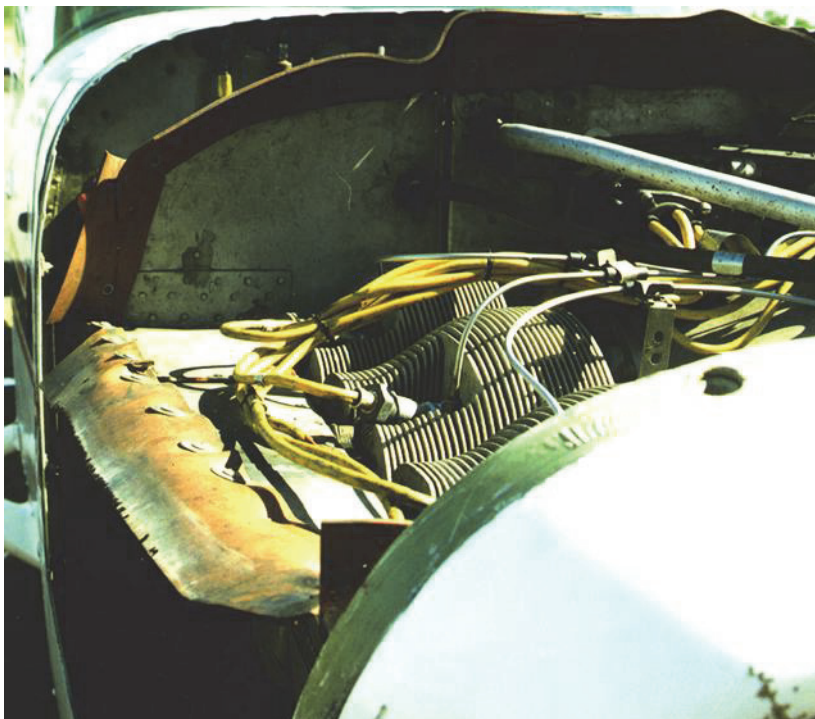

Figure 6-77. Improperly Positioned Aft and Side Peripheral Baffle Seals

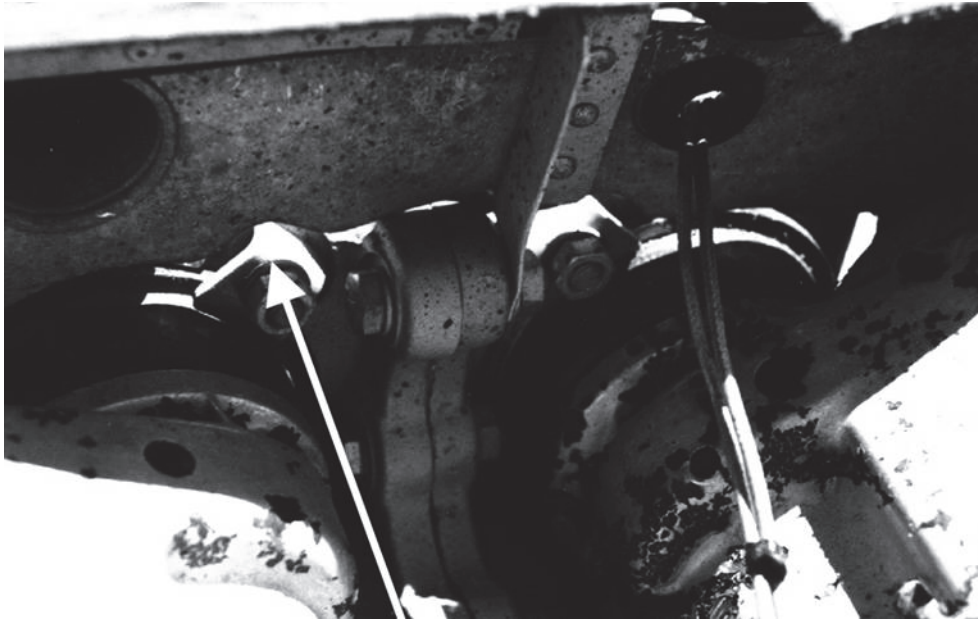

Figure 6-78. Aft and Side Baffles with Air Gaps

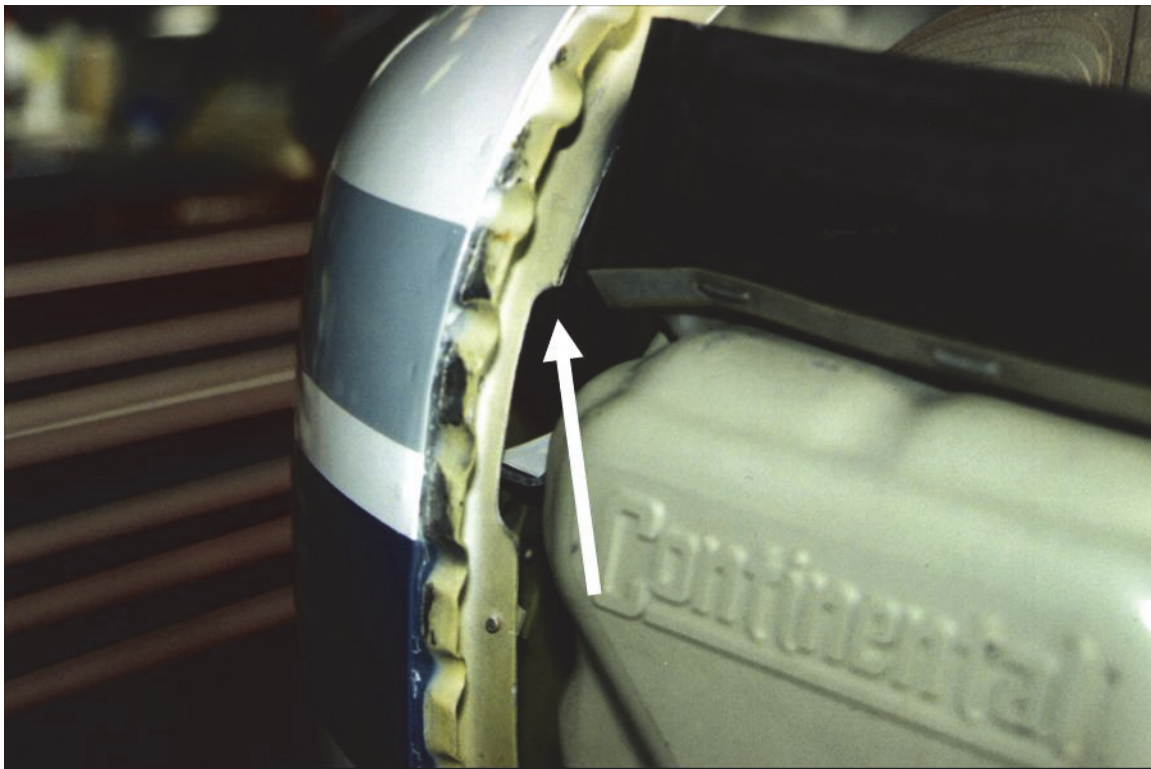

Figure 6-79. Cooling Loss Due to Gaps in Baffle Seals

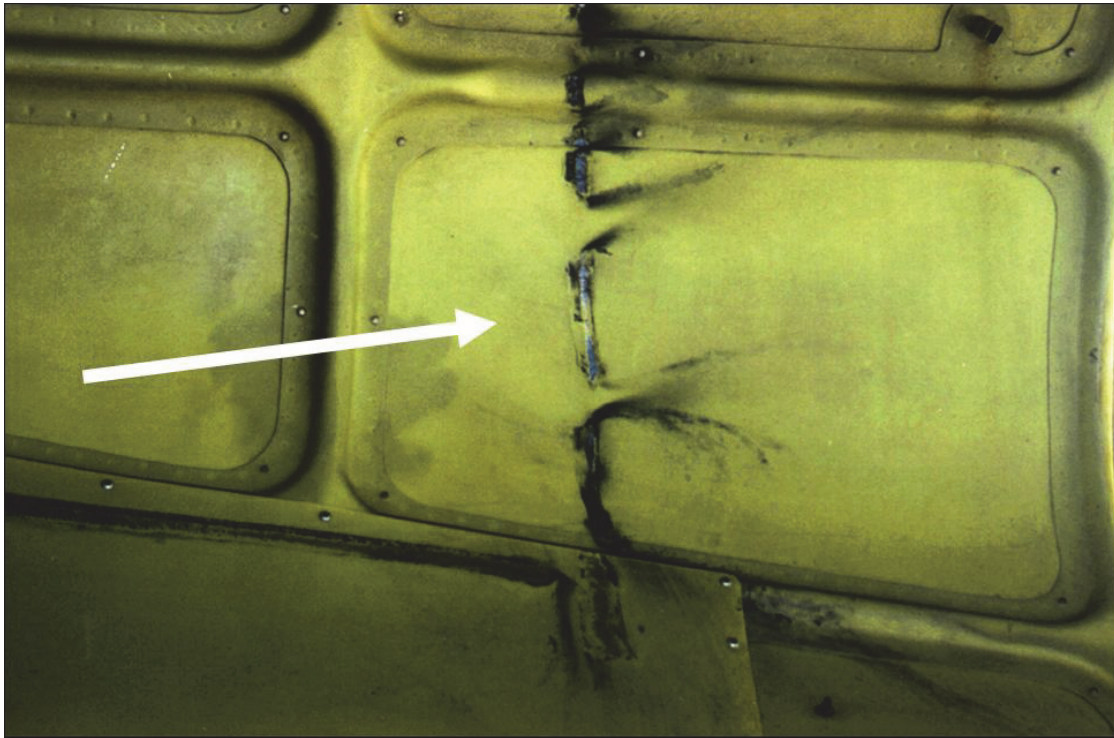

Figure 6-80. Cooling Loss Due to Gaps in Baffle Seals



6-4.11.6. Cowling Inspection

Purpose

Check cowl openings for restrictions and proper operation of the cowl flap. Cowl flap operation is an integral function of engine cooling control.

Frequency

During 100-hour/Annual inspection

Procedure

1. Verify add-on accessories and their associated hardware do not restrict cowl inlet, cowl outlet, and air flow through the cooling fins.
2. Verify the cowl flap rigging and operation meet the appropriate aircraft maintenance manual specifications.
3. Check for cracks and other obvious physical defects.

6-4.12. Crankcase Inspection

Product improvements over time have reduced material porosity and increased thickness in certain areas of our crankcases to improve structural integrity.

The part numbers for the engine model crankcases are minimum acceptable candidates for overhaul. Continental Motors will destroy any preceding crankcase part number when obtained as a core return.

Table 6-23. Crankcase Casting Numbers

Engine Model	Casting Number	Casting Part Number Introduction Year
O-300	530836/530837	1948
IO-360, LTSIO-360, TSIO-360	640432/640433	1973
520 Sandcast	640960/640961	1974
520 Permold	642000/642001	1977
GTSIO-520	642080/642081	1977

Purpose

To verify the crankcase is free of oil leaks, cracks, and physical damage.

Frequency

During 100-hour/Annual inspection

Procedure

WARNING

If neglected, crankcase cracks may progress to the point of causing major oil leakage or engine structural failure.

CAUTION: Dye penetrant inspection must be performed by a properly qualified mechanic in accordance with the dye penetrant manufacturer's instructions.



1. Visually inspect the exterior of the crankcase halves for cracks. Carefully inspect the entire external surface of the crankcase using an inspection light and mirror. If suspected cracks are discovered, perform a dye penetrant inspection according to the penetrant manufacturer's instructions to verify the condition.

NOTE: All crankcase cracks require attention, regardless of size or location. Do not ignore crankcase cracks.

Cracks are frequently accompanied by oil seepage; investigate all crankcases for indications of oil leaks.

- a. Cylinder deck (white/non-shaded in Figure 6-82 through Figure 6-88 = critical areas) cracks, regardless of size require **immediate crankcase replacement**.
- b. Repair cracks two inch (5.08 cm) or longer in the shaded (non-critical) locations of Figure 6-82 through Figure 6-88 according to instructions in Section 10-7.
- c. If a crack is found in the *non-critical* (shaded) area less than two inches (5.08 cm) in length **and** there is no oil leakage from the crack, the crankcase may remain in service, if the following conditions are met:
 - 1) If oil is leaking (visibly dripping) from the crack, repair or replace the crankcase immediately.
 - 2) Scribe the extremities of cracks smaller than two inches in the non-critical areas to monitor further growth progression.
 - 3) Inspect cracks previously identified in the non-critical stress areas of Figure 6-82 through Figure 6-88 for progression at 50-hour inspection intervals. If a crack in the non-critical area progresses to two inches or more in length, repair or replace the crankcase.
 - 4) Inspect the scribed cracks at the next 50 hour engine inspection for progression. If no progression is noted, repeat the progression inspection at each 100-hour inspection interval until the crack is repaired or the crankcase is replaced.
 - 5) Repair or replace the crankcase if cracks in the non-critical area progress to two inches or beyond in the shaded locations.

NOTE: Crankcase repairs are not possible with the engine mounted in the aircraft. To accomplish repair, remove the engine from the aircraft, disassemble the engine and send the crankcase to a Part 145 Repair Station certified to perform the crankcase repair.

- d. Replace the crankcase immediately, if:
 - 1) Any crack is observed in the critical (white/non-shaded) area.
 - 2) A crack is observed in any of the non-critical (shaded) areas two inches (5.08 cm) or more in length.
 - 3) Any oil is leaking from the crack in the crankcase.
 - 4) At overhaul, crankcase casting part number is listed in Table 6-23.

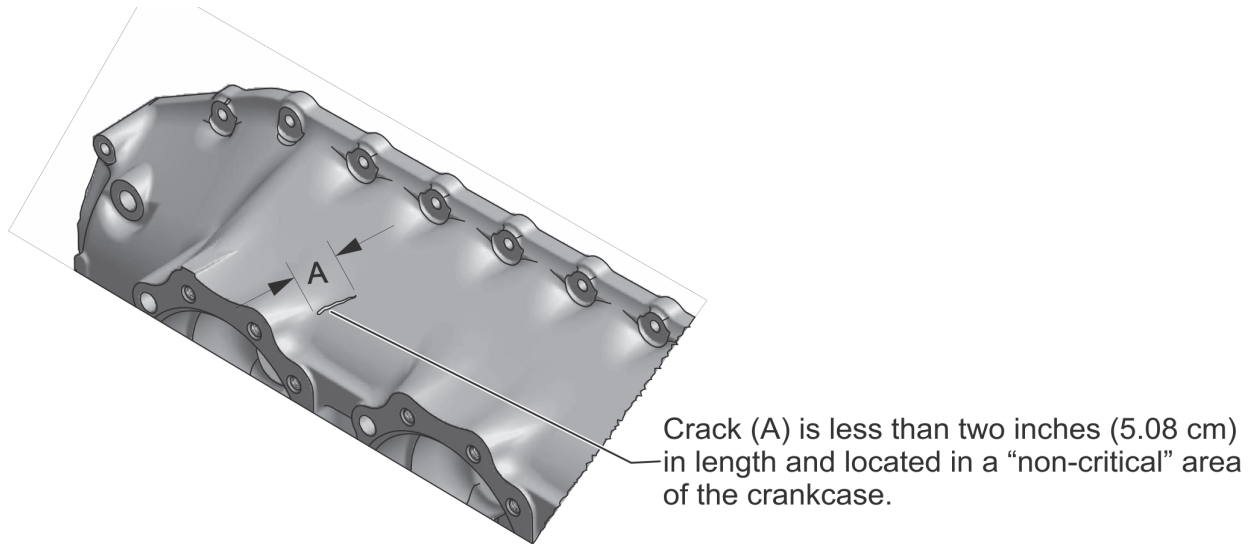

Figure 6-81. Crack in Non-Critical Area of Crankcase, *typical*

2. Investigate oil leaks as possible crack indications. If oil leaks are the result of damaged or improperly sealed gaskets, replace questionable gaskets according to the overhaul instructions.
3. Inspect the crankcase breather for cracks or dents; inspect tube ends for scoring or eccentricity that may prohibit a proper seal. Discard and replace unserviceable components.
4. Inspect engine mount brackets for cracks, dents and wear. Inspect hardware for distorted, stripped threads and damaged wrench flats. Discard and replace unserviceable components.
5. Inspect the crankcase backbone seam for signs of oil leaks. Oil leakage in this area may be caused by improperly torqued through bolts. If through bolt torque is less than the minimum specifications, remove, disassemble, and inspect the engine immediately to determine the cause of through bolt torque loss.

WARNING

The use of sealants or lubricants other than those specified herein on mating threads and between mating surfaces may cause incorrect torque application and subsequent engine damage or failure.

6. Inspect the cylinder deck for signs of RTV Sealant used on the cylinder deck flange. If RTV Sealant is found, refer to Section 6-4.11.4, “Cylinder to Crankcase Mounting Deck Inspection” for corrective action.

6-4.12.1. Crankcase Critical Stress Areas

Illustrations in Figure 6-82 through Figure 6-88 depict critical stress areas on the crankcase as white/non-shaded; non-critical stress areas of the crankcases are shaded in the illustrations.

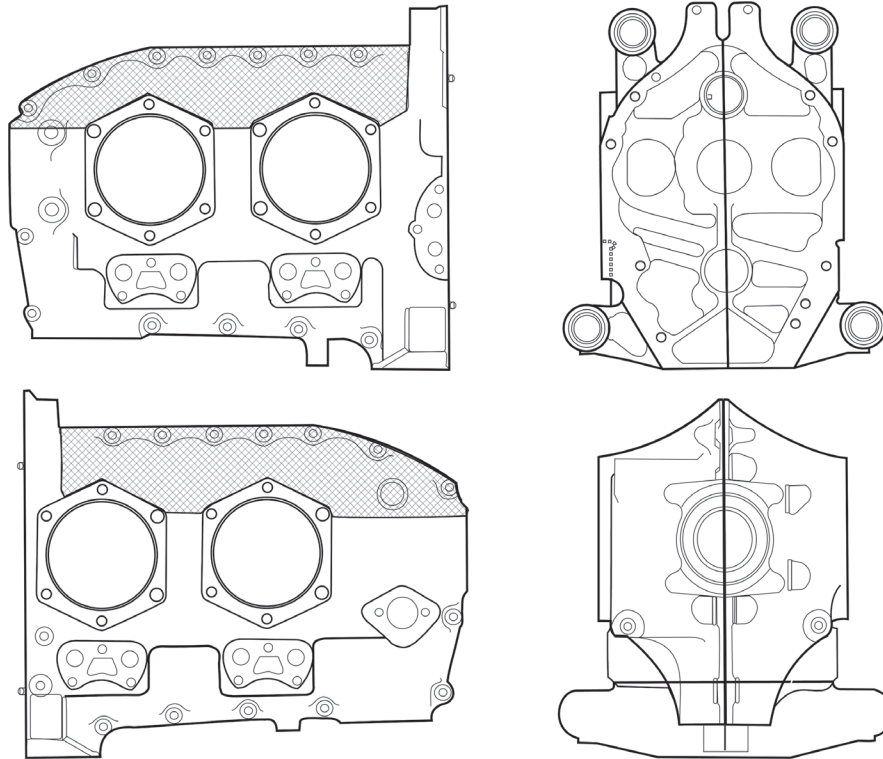

Figure 6-82. O-200 Engine Crankcase

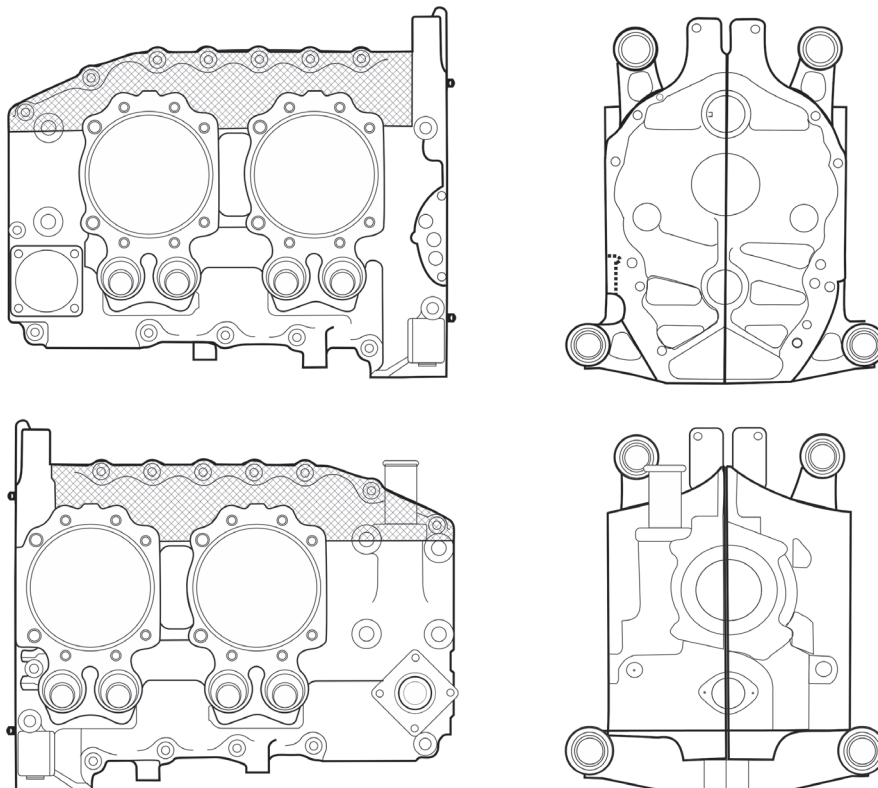

Figure 6-83. IO/IOF-240 Engine Crankcase

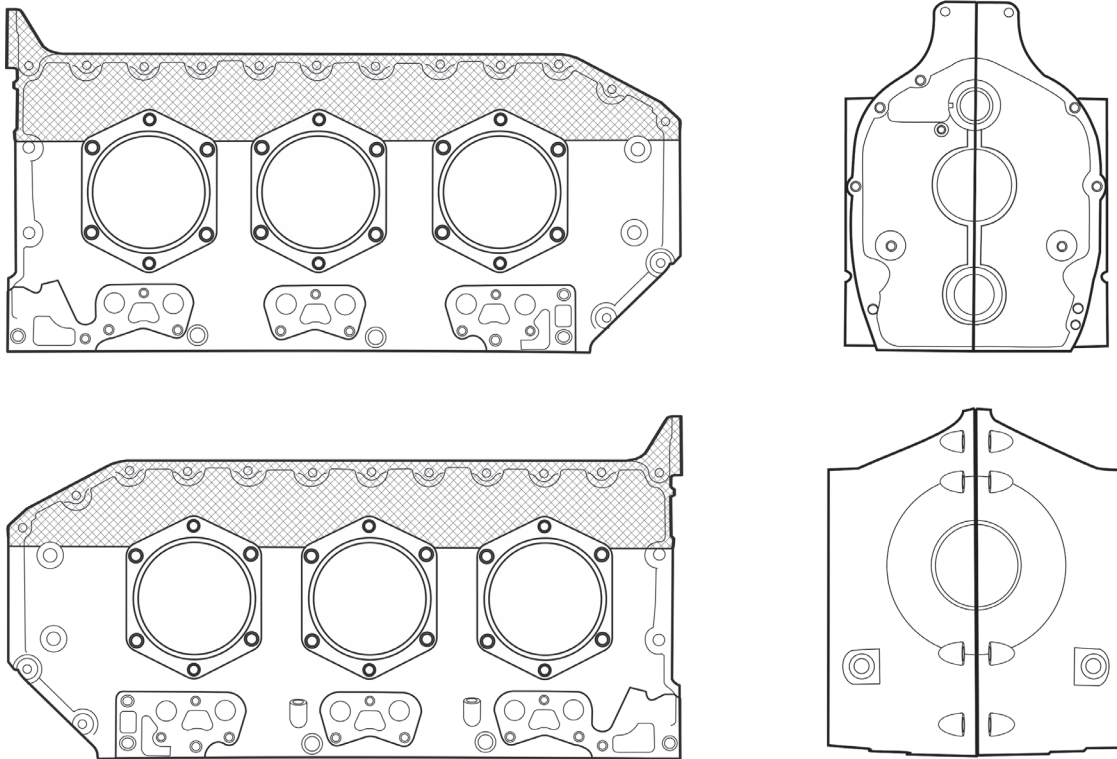

Figure 6-84. O-300 Engine Crankcase

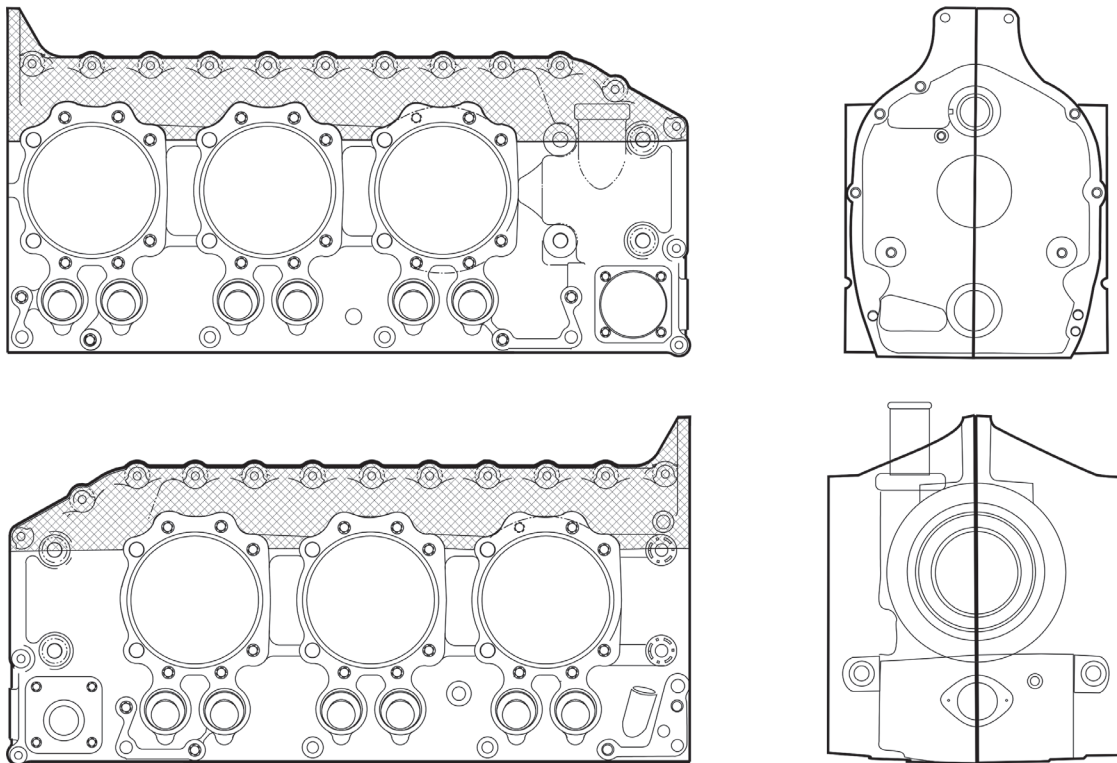

Figure 6-85. IO/LTSIO/TSIO-360 Series Engine Crankcase

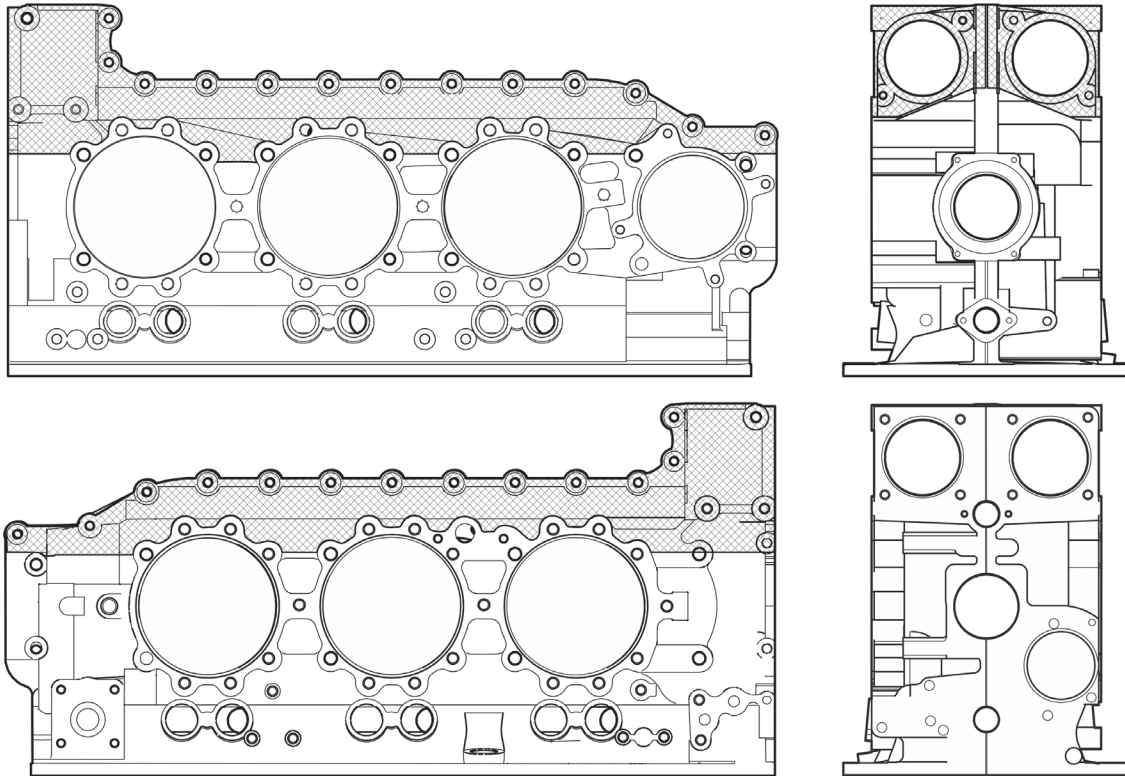

Figure 6-86. 520/550 Permold Engine Crankcase

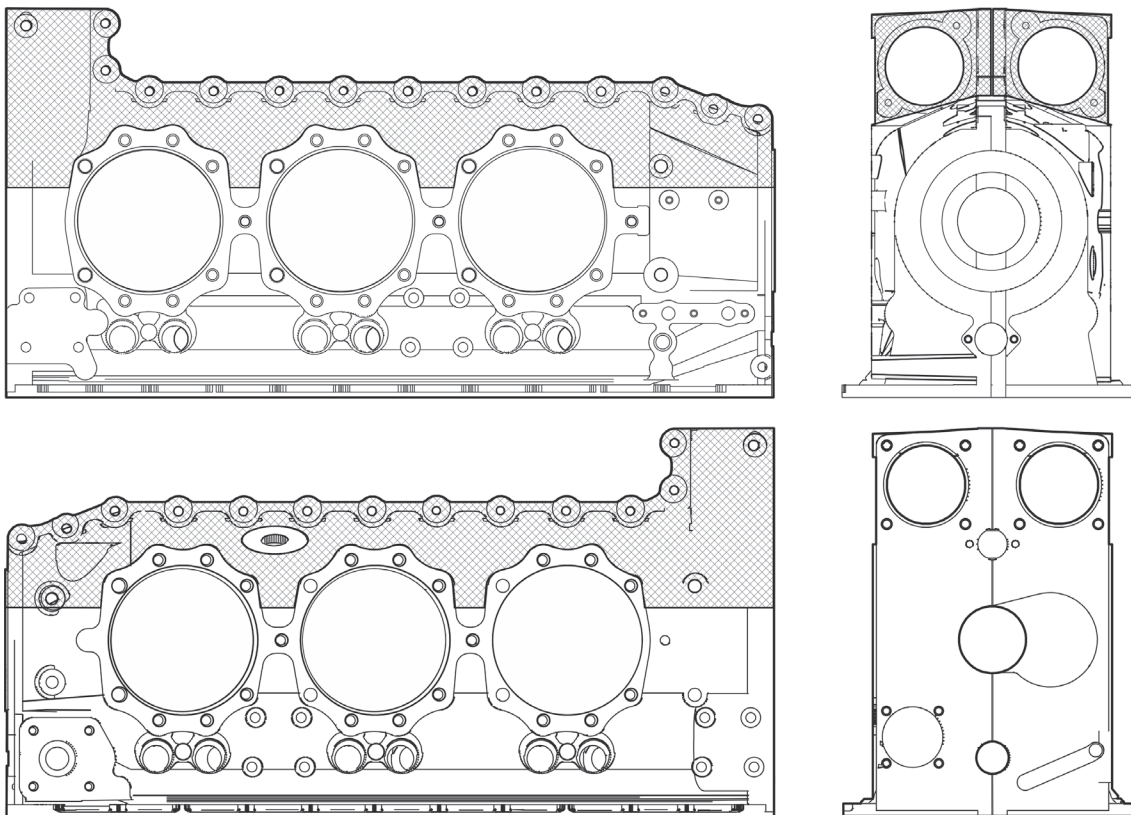

Figure 6-87. 470/520/550 Sandcast Engine Crankcase

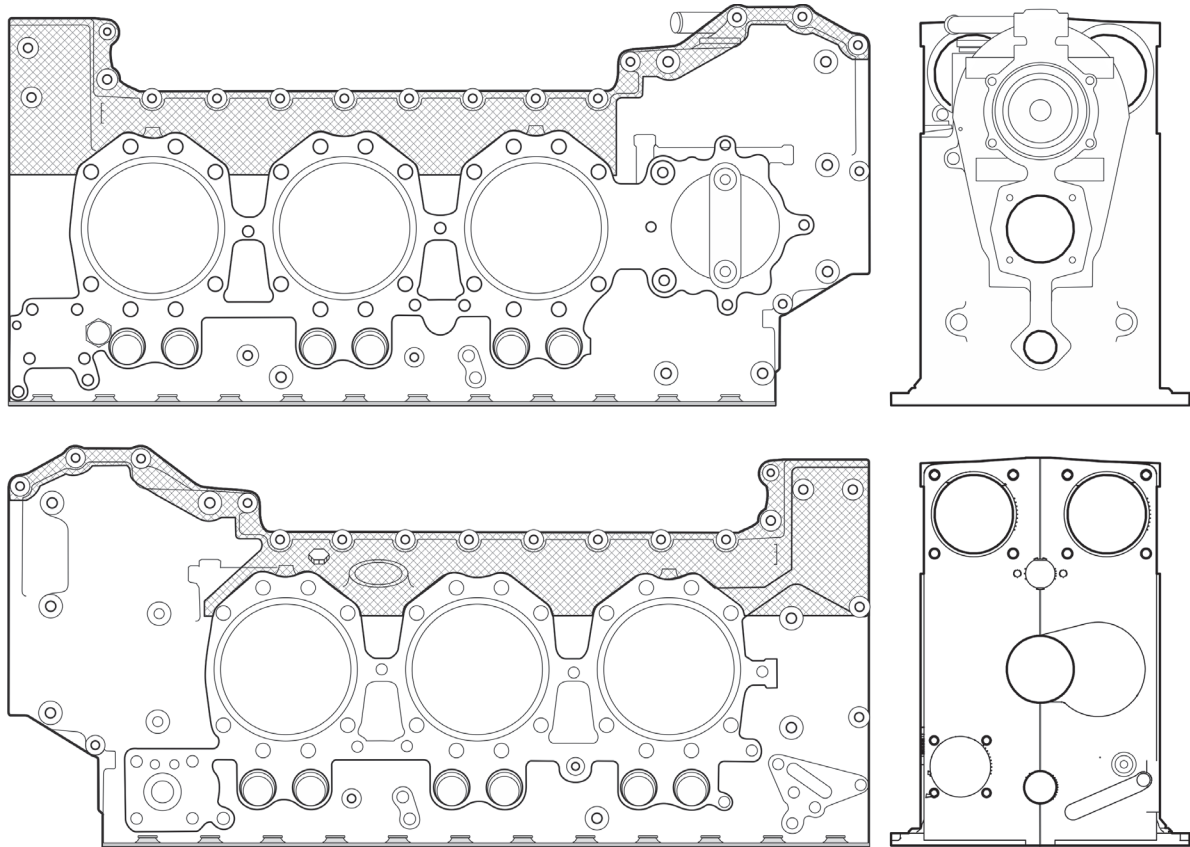

Figure 6-88. GTSIO-520 Engine Crankcase



Intentionally Left Blank



6-4.13. Engine Mount Inspection

Frequency

During 100-hour/Annual inspection

Procedure

1. Inspect engine mounts for signs of cracks, deterioration, proper assembly and security. If cracks are suspected, perform a nondestructive inspection using fluorescent penetrant or eddy current methods to determine engine mount condition.
2. Inspect engine mount isolators for signs of deterioration, proper assembly and security. Replace engine mount isolators exhibiting any of these conditions.

WARNING

**Do not allow a cracked engine mount to remain in service.
Replace upon discovery.**

3. Replace damaged or deteriorated engine mounts or engine mount isolators.

6-4.14. Induction System Inspection

Purpose

Check the integrity of the air filter, seals, and airbox to prevent particulates from entering the engine that can abrade cylinder walls and ring faces thereby damaging the engine.

Frequency

During 100-hour/Annual inspection

Procedure

1. Remove and inspect the induction air filter for cleanliness, normal operation and the absence of gaps or leaks in the filtering element. Verify the air filter seal prevents airflow except through the filter. Inspect or replace, as required, according to the aircraft manufacturer/STC holder's instructions.
2. Verify the integrity of the airbox; look for alternate air circuits which can bypass the filtering system. Any holes or bypass circuits found behind the filtering element should be repaired, as required, according to the aircraft manufacturer/STC holder's instructions.
3. Verify operation of the alternate air door and the integrity of the seal in the closed position. Verify the door operating mechanism closes securely. Replace or repair, as required, according to the aircraft manufacturer/STC holder's instructions.
4. If oil analyses are done on engine oil samples, check the silicone content of the most recent oil analysis and the overall silicone trend to further assess the possibility of Induction System leaks or pilot operational issues such as extensive use of carburetor heat or alternate air during ground operation.
5. Inspect the induction tube and hose connections to verify proper installation. Induction tubes incorporate a "bead" (Figure 6-89) which provides an anchor point for the induction tube clamps and enhances the seal between the induction tube and hose. Remove, inspect and install induction system according to instructions in the applicable Maintenance and Overhaul (or Overhaul) Manual if induction tubes,



hoses or clamps are improperly installed or inspection identifies parts as unserviceable.

- a. Visually inspect the induction system clamps for proper fit and positioning. Clamps should be positioned squarely over the joint between the induction tubes and hose (Figure 6-89), inboard of the induction tube bead; no part of the end of the induction tube should be visible with the hose and clamp properly installed. Loosen the clamps, reposition, and torque the clamps 25-35 in. lbs. If the clamp will not tighten or remain torqued, the clamp is unserviceable - replace the clamp.
- b. Perform a visual inspection on the induction hoses for proper fit and positioning. Hoses should be flexible; splits, tears, or cracks are unserviceable conditions. Replace cracked, split, or torn induction hoses. Hoses should not exhibit “twists” from misalignment, which can cause stress cracks. Hoses must be positioned over the induction tubes to secure the induction tube beads within the clamped portion of the hose.
- c. Perform a visual inspection on the induction tubes. Replace tubes exhibiting deep scratches, dents, cracks, or eroded sealing beads.

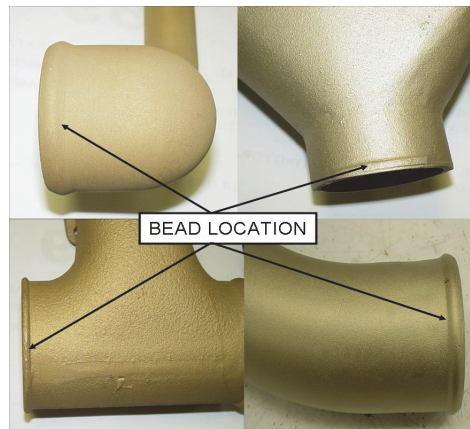

Figure 6-89. Induction Tube Bead Location

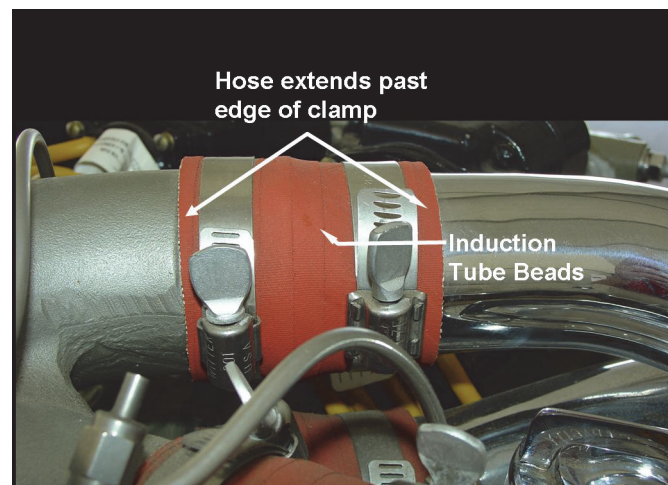
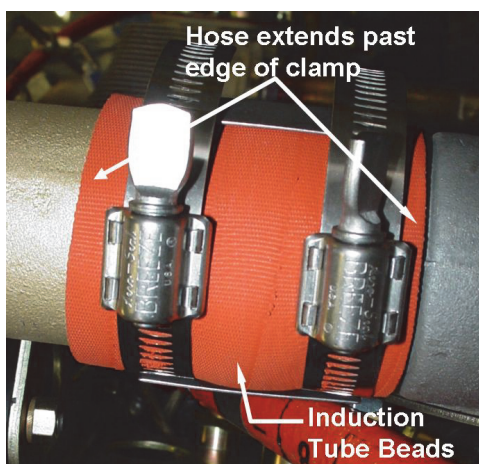

Figure 6-90. Properly Installed Induction Tube, Hose and Clamps



6-4.15. Ignition System Inspection

Purpose

Verify the following:

- Magneto housing and flange is free of damage
- Magneto to engine timing is set properly
- Ignition leads are intact and secure
- Spark plugs are clean, operating properly, and correctly gapped

Frequency

During 100-hour/Annual inspection

Procedure

WARNING

Turn the Ignition Switch OFF and disconnect engine electrical power before commencing maintenance or inspections. Confirm continuity between the magneto capacitor and aircraft ground to prevent an accidental engine start. Do not stand or place equipment within the arc of the propeller.

1. Ignition Switch..... OFF
2. Remove the spark plug leads from the top and bottom spark plugs and ground the leads to the engine.
3. Verify the magnetos are properly grounded.
4. Clean the ignition leads and visually inspect the ignition leads for chafing, deterioration and insulation breakdown. Replace worn, frayed or chafed ignition wires.
5. For engines equipped with impulse coupled magnetos, perform an “Impulse Coupling Functional Check” according to the instructions in Section 6-4.15.1.
6. Remove the spark plugs from each cylinder. Clean, inspect, and rotate spark plugs according to instructions in Section 6-4.9.2.

WARNING

Failure to maintain the magneto, spark plugs and ignition leads can cause engine damage or failure due to misfire.

7. Perform the “Crankshaft Top Dead Center Alignment” in Section 6-4.9.1.1 to position the crankshaft to the proper position from magneto to engine timing.
8. Visually inspect the external surfaces of the magneto for physical security or corrosion. Replace non-Continental Motors magnetos exhibiting damage, unusual wear or corrosion. Correct Continental Motors magneto discrepancies according to the Magneto Service Manual.
9. For pressurized magnetos:

NOTE: Pressurized magnetos are equipped with a desiccant filter; the filter media is normally white in color and darkens when contaminated.



- a. Inspect the magneto filter body, pressurization fittings, and hoses for physical condition and security. Replace missing, cracked or damaged magneto pressurization parts.
- b. Inspect the filter media for contamination; the media within the translucent filter body should be uniform in color and shape. If the media appears to be contaminated, discard and replace the filter with a new one (Magneto Filter Replacement in Chapter 10, Non-Overhaul Repair and Replacement).
- c. Verify the filter is installed with the drain positioned farthest from the magneto; if properly installed, the arrow on the filter body will point toward the magneto and the drain will be physically lower than the inlet and outlet fittings for proper drainage. Adjust filter installation to ensure the drain is lower than the fittings.

CAUTION: Verify the magneto pressurization vent is open. If the vent is clogged, nitric acid formation in the magneto will cause rapid degradation of the magneto internal components, leading to imminent magneto failure.

- d. Verify the reducer is fully seated in the bottom of the filter drain tube and the orifice is clear of debris to allow for drainage. If liquid is accumulated in the bottom of the filter, the drain or magneto vent may be clogged:
 - 1) Replace the desiccant filter.
 - 2) Remove, disassemble and inspect Continental Motors magnetos for corrosion according to the instructions in the Magneto Service Manual. Remove and replace Champion (Slick) Magnetos with new or serviceable units.
10. Perform a 100-Hour inspection on Continental Motors magnetos according to instructions in the Magneto Service Manual.
11. Note the magneto RPM drop test results recorded during the “Engine Operational Check” in Section 6-4.7. If magneto RPM drop or spread during run-up was not within published limits, inspect, troubleshoot, repair and adjust as required to correct discrepancy.
12. Check magneto to engine timing according to the “Magneto to Engine Timing” instructions in Section 6-4.9.1.2. If magneto timing cannot be adjusted:
 - a. Remove the magneto from the engine according to the instructions in Section 10-5, “Magneto Replacement.”
 - b. Perform a “Magneto Drive Coupling Inspection” according to the instructions in Section 6-4.15.3.
 - c. Replace Champion (Slick) magnetos with a new, rebuilt, or serviceable magneto. Troubleshoot and repair Continental Motors magnetos according to instructions in the Magneto Service Manual.
13. For engines equipped with a shower of sparks ignition system, perform a “Starting Vibrator Functional Check” according to the instructions in Section 6-4.15.2 after verification of magneto to engine timing.



6-4.15.1. Impulse Coupling Functional Check

This functional check is a simple method to determine if the magneto impulse couplings are functioning properly without disassembly. This functional check is not a suitable substitute for the impulse coupling inspection in the Magneto Service Manual.

WARNING

Do not stand or place equipment within the arc of the propeller.

Procedure

1. Disconnect the ignition harness from all spark plugs and ground the ignition harness leads to the engine.
2. Remove top spark plugs from the engine
3. Mixture Control IDLE CUT-OFF
4. Throttle..... CLOSED
5. Fuel Selector Valve OFF
6. Master Power Switch..... ON
7. Crank the engine several revolutions using the Start switch (if separate from the Ignition switch) or Ignition switch (if start function is controlled by the Ignition switch).
RESULT: Impulse coupling operation is audible and can be felt through the magneto housing. The “clicking” sound from the impulse couplings should be consistent while the engine is cranked. If no “clicking” is heard, or the clicking is intermittent, remove the magnetos and service according to the manufacturer's instructions.
8. Disconnect the aircraft battery according to the aircraft manufacturer's instructions.
9. For shower of sparks ignition only: Turn and hold the Ignition Switch in the START position and verify continuity between the right magneto P-lead and ground. If continuity is not present, repair the circuit before proceeding.
10. Ignition Switch..... OFF
11. Disconnect the P-lead from each magneto. Verify continuity between both magneto P-leads and ground with a multimeter. If either circuit is faulty, repair the circuit before proceeding.
12. Reconnect the magneto P-leads and place the Ignition Switch in the OFF position.
13. If ignition system maintenance is complete, install top spark plugs (with new gaskets) according to instructions in Section 6-4.9.2 and reconnect the ignition harness according to the instructions in Section 6-4.9.3.



6-4.15.2. Starting Vibrator Functional Check

WARNING

Do not stand or place equipment within the arc of the propeller.

1. Disconnect aircraft electrical power from the starter according to the aircraft manufacturer's instructions.
2. Perform the “Crankshaft Top Dead Center Alignment” instructions in Section 6-4.9.1.1 to position the No. 1 cylinder at the proper ignition timing position.
3. Remove the lower spark plug lead from the No. 1 cylinder. Position the tip of the spark plug lead 3/16” from engine ground.
4. Master Switch ON

CAUTION: The starting vibrator duty cycle is 16.6% or 20/120 seconds; do not engage the starting vibrator for longer than 20 seconds in a two minute period. Exceeding the duty cycle will overheat the circuit and may damage the starting vibrator.

5. Ignition Switch.....START (maximum 20 seconds)
RESULT: A strong blue spark emits from the spark plug lead at a few degrees before top dead center on the No. 1 cylinder compression stroke. If no spark is observed before the maximum advanced position, inspect the left magneto main and retard contact point timing circuit according to the appropriate manufacturer's Magneto Service Manual.
6. Reconnect the spark plug lead to the No. 1 cylinder lower spark plug.
7. Reconnect aircraft electrical power to the starter according to the aircraft manufacturer's instructions.

6-4.15.3. Magneto Drive Coupling Inspection

1. Remove the magnetos from the engine according to the “Magneto Replacement” instructions in Section 10-5.
2. Inspect the drive coupling bushings and retainers for serviceability and proper installation. If the bushings are torn or exhibit missing material, perform a “Foreign Object Contamination Inspection” according to instructions in Section 6-5.7.
3. Perform a “Gear Tooth Inspection” according to instructions in Section 11-1.1 on the magneto drive gear and idler gear assembly. Rotate the crankshaft 360° in order to inspect the circumference of the gear. If the gear teeth are chipped, broken, or otherwise damaged, remove, inspect and make repairs, if necessary, to the magneto drive gear or accessory drive adapter according to instructions in the primary ICA (**Ref: Section 1-1.1**). Perform a “Foreign Object Contamination Inspection” according to instructions in Section 6-5.7.



6-4.16. Engine Gauge Inspection

CAUTION: Inaccurate aircraft engine related gauges can cause operation outside of engine certification and specification limits. Aircraft gauge calibration errors can be particularly harmful for high horsepower engines. Gauges may require re-marking for modified (STC) engines. Significant aircraft engine gauge inaccuracies can lead to engine damage.

Purpose

Verify proper gauge operation and ensure reliable condition feedback to the pilot.

Frequency

During 100-hour/Annual inspection

Procedure

Verify the following indicators are working properly according to instructions in the Aircraft Maintenance Manual. Repair or replace faulty components.

- Tachometer
- Manifold pressure gauge
- Fuel flow gauge
- Oil pressure gauge
- Oil temperature gauge
- Cylinder head temperature gauge
- Exhaust gas temperature gauge
- Turbine inlet temperature gauge (if equipped)

NOTE: Verify the accuracy of the EGT/TIT indicating system. The aircraft manufacturer may require EGT/TIT reporting be operational for all categories of flight. Consult the Aircraft Maintenance Manual for interval and operational requirements. In many cases, EGT/TIT calibration is a 100-hour inspection requirement.



6-4.17. Fuel System Inspection

Engine operation and cooling are directly related to the correct fuel-air ratio. Improper fuel settings can affect engine performance in terms of both power and throttle response. For FADEC engines, refer to the “Fuel System Inspection” in the primary ICA.

Purpose

- Verify fuel injector operation
- Verify fuel lines are clear
- Verify the fuel pump is properly adjusted

Frequency

- During 100-hour/Annual inspection
- Clean fuel injectors at the first 100-hour inspection and every 300 hours (or annually) thereafter, whichever comes first.

Procedure

1. Inspect each fuel line to the connection point at the fuel manifold valve for chafing, wear, or damage. Replace worn, chafed or damaged fuel lines with new fuel lines.
2. Inspect the fuel manifold valve for leaks and security of fittings.
3. Clean the fuel injectors:
 - a. Remove the fuel injectors (Section 10-2.2 or Section 10-2.4) from the cylinders. Remove the O-rings from the fuel injectors, if present.
 - b. Clean the fuel injectors in an ultrasonic cleaner. If an ultrasonic cleaner is not available, soak the fuel injectors in lacquer thinner. After successful cleaning, use dry, oil-free compressed air (from inlet to outlet) to remove residual cleaner from the nozzles.
 - c. Install the fuel injectors (Section 10-2.3 or Section 10-2.5).
4. Inspect the fuel line and fittings from the fuel pump outlet to the fuel manifold valve, including the fuel filter (if installed) for wear or damage. Replace faulty parts.
5. Turn the aircraft boost pump (if equipped) to the ON position.
 - a. Visually inspect the fuel pump, fuel lines, fuel manifold valve, fuel hoses and fittings for signs of fuel leaks.
 - b. Verify no fuel is leaking from the fuel pump dry bay drain.
 - c. Inspect each fuel injector to the fuel line connection point.
6. Turn the aircraft boost pump OFF.
7. Perform the “Fuel System Operational Check” according to instructions in Section 6-4.7.4.

NOTE: The “Fuel System Operational Check” is part of the “Engine Operational Check” performed at the beginning and conclusion of the 100-hour scheduled inspections.



6-4.18. Throttle and Mixture Control Lever Inspection

Reference: **CSB08-3**

NOTE: Continental Motors replaced bronze throttle and mixture control levers in all applications where the lever mated with a splined shaft with improved stainless steel control levers featuring machined splines in the chamfer where the control lever contacts the throttle or mixture control shaft splines.

This inspection does not apply to throttle and control assembly levers installed with a pin through the lever and shaft rather than a lock nut on a threaded shaft.

WARNING

Replace control levers or shafts exhibiting damage, deformation, or material loss. Improper or negligent control lever installation may result in loss of engine control.

Replace all bronze control levers on threaded shafts with the designated stainless steel equivalent during the next 100 hour or annual inspection or the next maintenance interval requiring removal of the lock nut on the lever to be removed, whichever comes first.

1. Inspect the serrated, chamfered edges of the control lever and shaft (Figure 6-91). Verify the serrations are well defined and mechanically interlock when assembled. If the splines are malformed or worn, slippage is possible; replace the control lever.

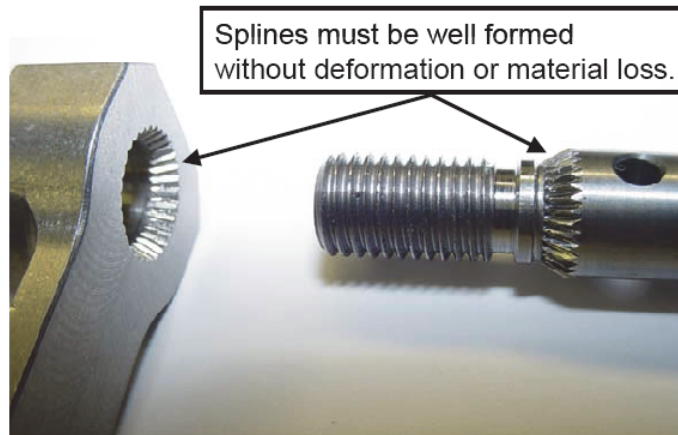

Figure 6-91. Serviceable Throttle/Mixture Control Lever & Shaft Splines

2. At installation, lubricate the shaft threads with clean 50-weight aviation engine oil, align the control lever to the desired angle, engage the splines in shaft with the splines in the lever, install a new lock nut and tighten the lock nut to secure the lever.

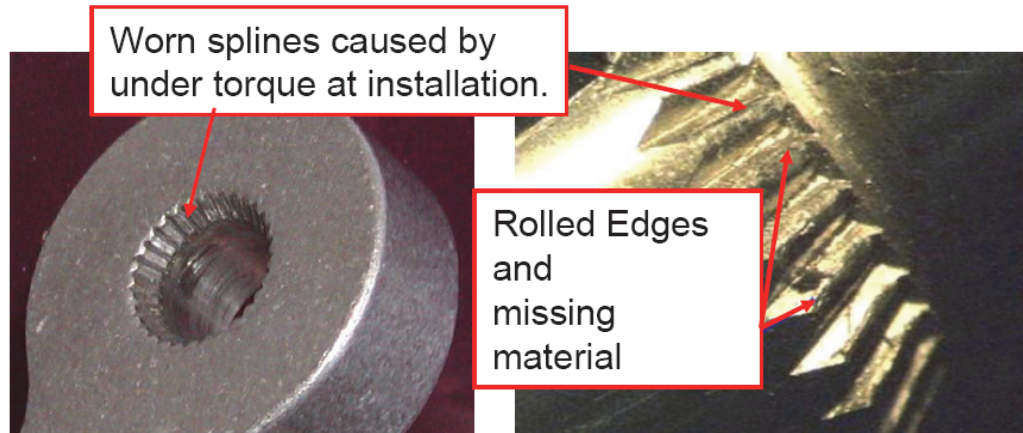

Figure 6-92. Worn Throttle and Mixture Control Lever & Shaft Splines

3. Rotate the lever away from the stop pin and apply 100-120 in. lbs. torque to the nut. Check the control lever after torque application to ensure there is no free play or movement of the control lever on the component shaft.
 - a. If free play or movement is felt after the nut is torqued, remove the control lever and determine the cause for movement (if applicable, reinstall the control lever and repeat the installation process).
 - b. If lever continues to exhibit free play after being torqued, replace the control lever. If the source of the free play is determined to be the fuel pump or throttle shaft, replace the next higher assembly (fuel pump or throttle assembly).



6-4.19. Engine Control Linkage Inspection

Purpose

To ensure proper operation and avoid accelerated wear, inspect the engine control linkage for excessive play, which may restrict control travel or damage control levers or cables.

Frequency

- During 100-hour/Annual inspection

Procedure

1. Inspect the pivot points of levers and linkages for debris, old grease, and oil.

WARNING

If the lock nut securing a bronze throttle or mixture control lever is loosened for any reason, replace the bronze lever with the appropriate stainless steel replacement lever.

2. Inspect throttle and mixture control lever condition and security according to the “Throttle and Mixture Control Lever Inspection” instructions in Section 6-4.18. Grasp the lever firmly and apply lateral force to the end of the lever. No free play is permitted between the shaft and control lever.
3. Replace worn or corroded linkage and attaching hardware according to the aircraft manufacturer's instructions.

CAUTION: When utilizing compressed air, wear OSHA approved protective eye wear. Never exceed 30 psi when using compressed gases for cleaning purposes. (OSHA 1910.242(b))

4. Clean pivot point areas thoroughly with Stoddard solvent. After cleaning, dry each area using compressed air.
5. Unless otherwise specified by the aircraft manufacturer's instructions, apply LPS 2, LOCTITE Maintain™ Lubricant, or equivalent, to each pivot point (Figure 6-93 or Figure 6-94), including the throttle shaft bushings.
6. Consult the aircraft manufacturer’s instructions concerning aircraft engine control cable attach point inspection, cleaning, repair, installation, and lubrication.
7. Cycle throttle and mixture controls through the full range of motion.
 - a. Verify each control has full range of travel and the required safeties are in place.
 - b. Ensure levers and linkages do not bind and control movement is unrestricted by parts or components in close proximity.

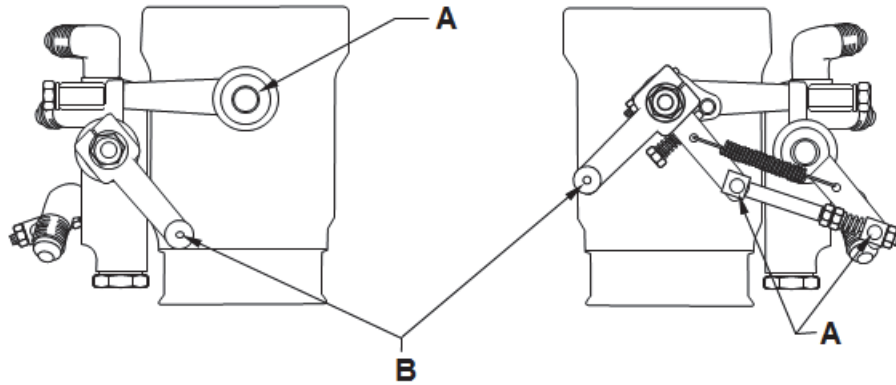

A – Clean, inspect, and lubricate according to instructions in this section.

B – Clean, inspect, and lubricate according to aircraft manufacturer’s instructions.

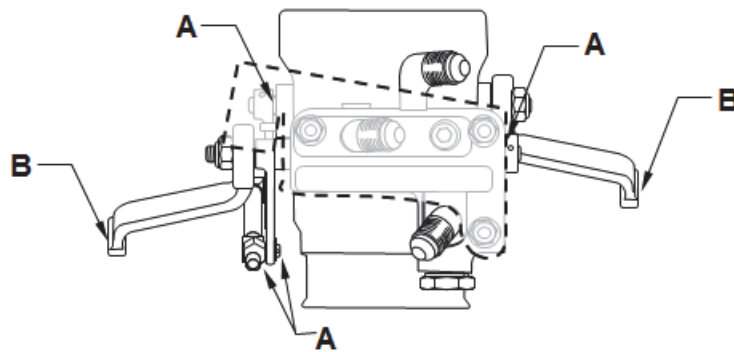
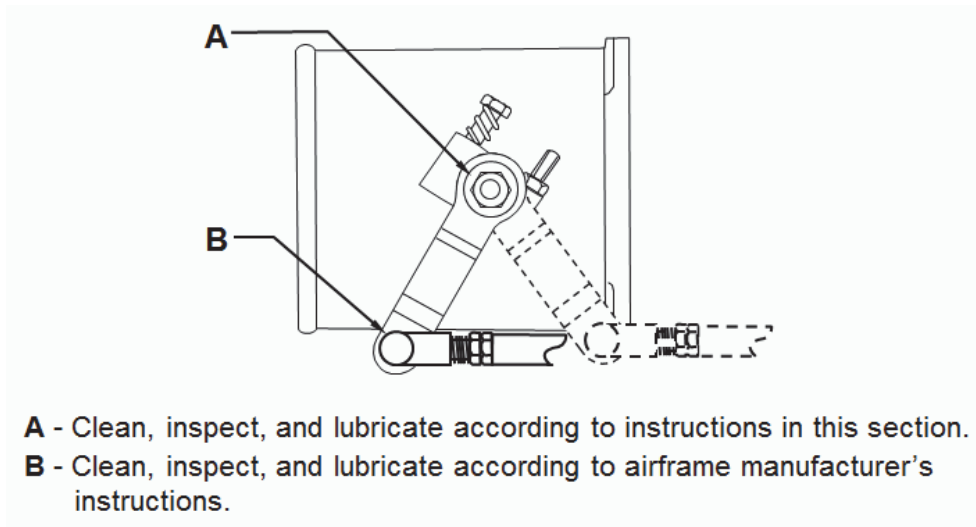

Figure 6-93. Throttle and Control Assembly Lubrication Points



A - Clean, inspect, and lubricate according to instructions in this section.

B - Clean, inspect, and lubricate according to airframe manufacturer’s instructions.

Figure 6-94. Throttle and Metering Assembly Lubrication Points

6-4.20. Induction System Drain Inspection

NOTE: This inspection only applies to fuel injected engines. Engines with carburetors do not offer induction system drains.

Induction system drains are incorporated on all engines featuring cross-flow (induction tubes above) cylinders. Engine models with updraft induction (below the cylinder) incorporate drains in the induction tubes to allow excess fuel to drain from the induction system. A check valve is incorporated in the induction drain to isolate the fuel in the induction system when the intake valve opens. Naturally aspirated engines use a two-way check valve. Because the induction system on turbocharged engines can operate in a negative pressure state, a three-way check valve is required for the turbocharged induction. An improved drain connector (Figure 6-95) was introduced in 2000 for improved cold weather starting characteristics. If the cylinder drain terminates at the taper (Part No. 632068), the drain connector is no longer available, replace with Part No. 655742, or later, if unserviceable, or to improve cold weather operation.

Purpose

Induction system drains evacuate excess fuel from the intake ports. Restricted induction system drains can accumulate excessive amounts of fuel and may cause hydraulic lock.

Frequency

During all periodic inspections

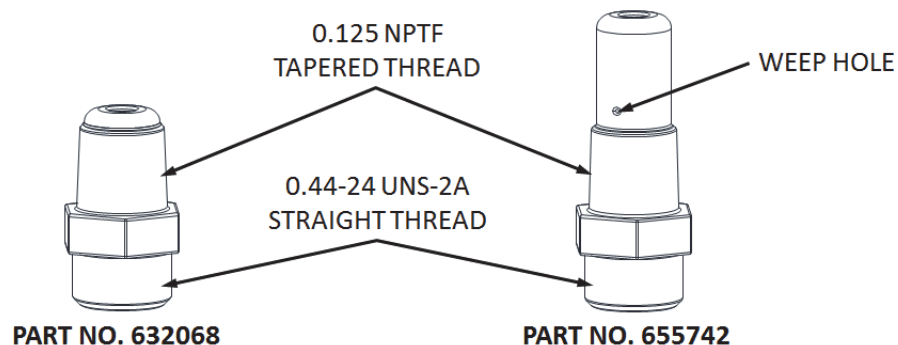

Figure 6-95. Induction Port Drain Connectors

Procedures

6-4.20.1. Induction System Drain Inspection (Naturally aspirated engines)

1. Remove the aircraft cowling according to the aircraft manufacturer's instructions.
2. At each 100-Hour/Annual Inspection, remove the connectors (Figure 6-95) from the cylinder head and clean according to the instructions in Section 10-3.1 and install serviceable, or new connector fittings in each cylinder according to the instructions in Section 10-3.2.
3. Connect a section of clear, fuel rated hose to the aircraft fuel drain outlet.



WARNING

Vacuum pumps are commercially available from a number of sources. Use only a spark-arrested vacuum pump, designed for use with flammable liquids.

4. Apply light vacuum (< -5 psi) from a spark-arrested source rated for flammable liquids to the clear hose connected to the aircraft fuel drain outlet and activate the aircraft engine fuel priming system for five seconds.
RESULT: Fuel drains from the hose into the container.
5. Apply light positive pressure (< 5 psi) from a spark-arrested source rated for flammable liquids to the clear hose connected to the aircraft fuel drain outlet and activate the aircraft engine fuel priming system for five seconds.
RESULT: Drain valve is closed - no fuel flows into the clear hose.
6. Remove air pressure source from the fuel drain hose. Allow the fuel in the hose to drain into a fuel rated container.
RESULT: Fuel drains from the hose into the container.

6-4.20.2. Induction System Drain Inspection (Turbocharged engines)

1. Remove the aircraft cowling according to the aircraft manufacturer's instructions.
2. At each 100-Hour/Annual Inspection, remove the connectors (Figure 6-95) from the cylinder head and clean according to the instructions in Section 10-3.1 and install serviceable, or new connector fittings in each cylinder according to the instructions in Section 10-3.2.
3. Connect a section of clear, fuel rated hose to the cylinder drain hose.

WARNING

Vacuum pumps are commercially available from a number of sources. Use only a spark-arrested vacuum pump, designed for use with flammable liquids.

4. Apply light vacuum (< -5 psi) from a spark-arrested source rated for flammable liquids to the clear hose and activate the aircraft engine fuel primer system for five seconds.
RESULT: No fuel flows into the clear hose.
5. Remove the vacuum source from the drain and allow the residual fuel to drain in to a fuel rated container.
RESULT: Fuel drains from the hose into the container.
6. Apply light pressure (< 5 psi) from a spark-arrested source rated for flammable liquids to the clear hose and activate the aircraft engine fuel primer system for five seconds.
RESULT: No fuel flows into the clear hose.
7. Remove air pressure source from the cylinder drain hose. Allow the fuel in the hose to drain into a fuel rated container.
RESULT: Fuel drains from the hose into the container.



6-4.21. Turbocharger and Exhaust System Inspection

Purpose

Verify the integrity of the turbocharger and exhaust system, including the heater muff (if installed). Isolate and correct cracks or leaks in the exhaust system.

Frequency

During 100-hour/Annual inspection

CAUTION: Ensure the turbocharger and exhaust system components are cool before inspection to prevent burns.

Procedure

1. Remove airframe items that hinder visual inspection of the exhaust and turbochargers.
2. Clean the exhaust system, removing oil and grease, by spraying the exhaust systems parts with Stoddard solvent. Allow the solvent to drain and wipe the parts with a clean cloth.

CAUTION: Cracks in the exhaust system can release carbon monoxide in the nacelle or the cabin; correct exhaust leaks before further flight.

3. Inspect the exhaust system components according to the instructions in Table 6-24.

Table 6-24. Exhaust Inspection Criteria

Part	Inspection Action
Stacks Risers Elbows	Check parts for the following: <ul style="list-style-type: none"> • Burned areas • Cracks • Loose parts/hardware • Pay particular attention to welded areas and seams, checking for cracks. • Replace parts that are cracked, burned, or worn
Slip joints	Check for bulges, cracks, or hot spots (see Figure 6-96)
Multi-segment V-band clamps	Inspect spot-weld (or rivet) areas for cracks or physical damage. Inspect the corner radii of clamp inner segments for cracks with a flashlight and mirror. Inspect the inner segment spacing. Inspect the clamp outer band for flatness using a straight edge, especially within 2 inches of spot-weld tabs that retain the T-bolt fastener - clearance must be less than 0.062 inches. Verify 100% inner and outer band segment contact. To replace a multi-segment V-band clamp, refer to the primary ICA. Ref: Section 1-1.1
Heater muff	Inspect the heat exchanger seams, joints and transitions with a flashlight and mirror or a flexible borescope for physical damage, cracks, corrosion, and burn-through. Inspect connecting flanges for security and proper mating.

4. Connect a high volume, dust-free, air pressure source to the exhaust tailpipe outlet.
5. Apply five (5) psi of air pressure to the exhaust system.

6. Apply soapy water to the exhaust system and check for bubbling in areas of the exhaust other than the slip joints. If bubbling is found, replace the leaking exhaust components according to the instructions in primary ICA (**Ref: Section 1-1.1**) or aircraft maintenance manual.

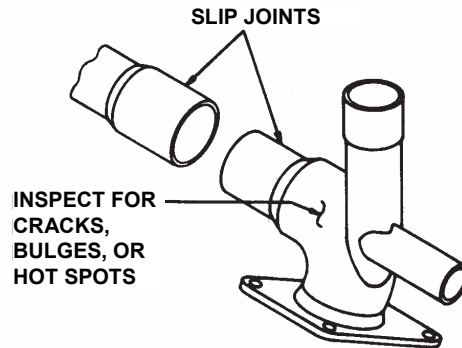

Figure 6-96. Exhaust Slip joint Inspection

WARNING

Exhaust system weld repairs may only be performed by an FAA Part 145 authorized repair station certified to perform the specific repairs.

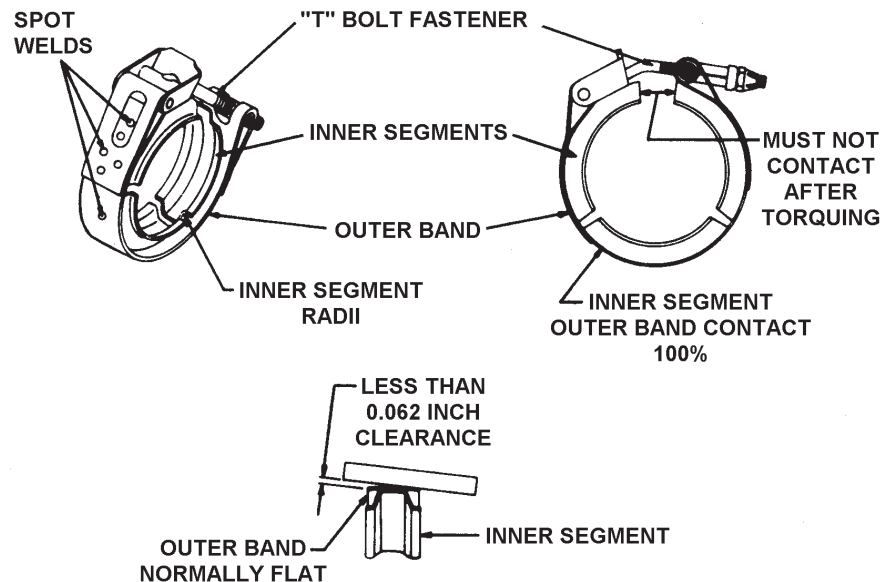

Figure 6-97. V-band Clamp Inspection

7. Visually inspect the exhaust stacks and transition unit for wear, leaks, cracks, or distortion. Replace worn, leaking, cracked, or distorted exhaust parts. Inspect the exhaust manifold connections at the cylinder to verify the physical security of the exhaust flange, gasket and exhaust manifold fasteners. Exhaust system removal and installation procedures may be found in the primary ICA (**Ref: Section 1-1.1**) or the aircraft maintenance manual, if disassembly is required.



Engine Inspection and Service

8. Remove the multi-segment V-band clamps from the exhaust tailpipes according to instructions in the primary ICA (**Ref: Section 1-1.1**) or the aircraft maintenance manual. Clean the outer band of the multi-segment V-band clamps with crocus cloth. Inspect the V-band clamps according to the instructions in Table 6-24.
9. Inspect the turbocharger oil reservoirs, oil inlet and outlet fittings and surrounding area for signs of leakage. Torque fasteners or fittings to Appendix B specifications or replace leaking parts, as required to remedy leaking reservoirs or fittings.
10. Remove the induction air supply from the turbocharger compressor according to the aircraft manufacturer's instructions. Inspect the induction air supply duct for wear, deformation, cracks or other physical damage; replace, if necessary.
11. Remove the turbocharger compressor discharge duct from the induction system according to instructions in the primary ICA (**Ref: Section 1-1.1**) or the aircraft maintenance manual. Inspect the hardware for wear, deformation, cracks or other physical damage; replace, if necessary.
12. Inspect the turbine and compressor housings for cracks or physical damage, especially at the mounting flanges. If cracks or physical damage is discovered, replace the turbocharger with a new, rebuilt or serviceable unit.
13. Inspect the turbine and compressor wheel blades for damage. If turbine or compressor blades are damaged, replace the turbocharger with a new, rebuilt or serviceable unit.
14. Spin the turbine shaft to check for freedom of movement and end play. If the turbine or compressor blades touch the housing during rotation, if the shaft does not rotate freely, or if the shaft exhibits noticeable "wobble" during rotation, replace the turbocharger with a new, rebuilt or serviceable unit.
15. Inspect the interior of the turbine and compressor housings for oil, indicating oil seal damage or a faulty check valve. If oil is found inside the housing, troubleshoot to isolate cause of oil accumulation.
16. Inspect the wastegate for cracks or physical damage. If the wastegate is cracked or damaged, replace the wastegate with a new, rebuilt or serviceable unit. Inspect the security of the mounting flange fasteners, retorque if fasteners appear loose.
17. Inspect the wastegate actuator fittings for leaks and physical security; retorque loose fittings to Appendix B specifications. If leaks persist, replace O-rings, retorque fittings and repeat leak inspection after a ground engine run. Inspect the wastegate actuator hydraulic hoses for chafing, nicks, cuts or leaks; replace hoses exhibiting these conditions.
18. Inspect the wastegate actuator and butterfly valve for general condition and freedom of movement. Check the link rod pins and levers for wear. If the wastegate actuator, butterfly valve, link rod pins or levers are worn, binding, or damaged, replace the wastegate actuator.



19. Clean and lubricate the butterfly valve and associated linkages:
 - a. Inspect fixed wastegate valves according to the instructions in the primary ICA (**Ref: Section 1-1.1**).
 - b. For variable wastegate valves resembling the Figure 6-97.1, lubricate the butterfly shaft with Mouse Milk® (see Table 3-5) penetrating lubricant at initial installation and at each 100-hour maintenance interval.

NOTE: The installed wastegate may be positioned in a manner that differs from the illustration. The fittings used to connect the hydraulic hoses may differ from those depicted in the illustration.

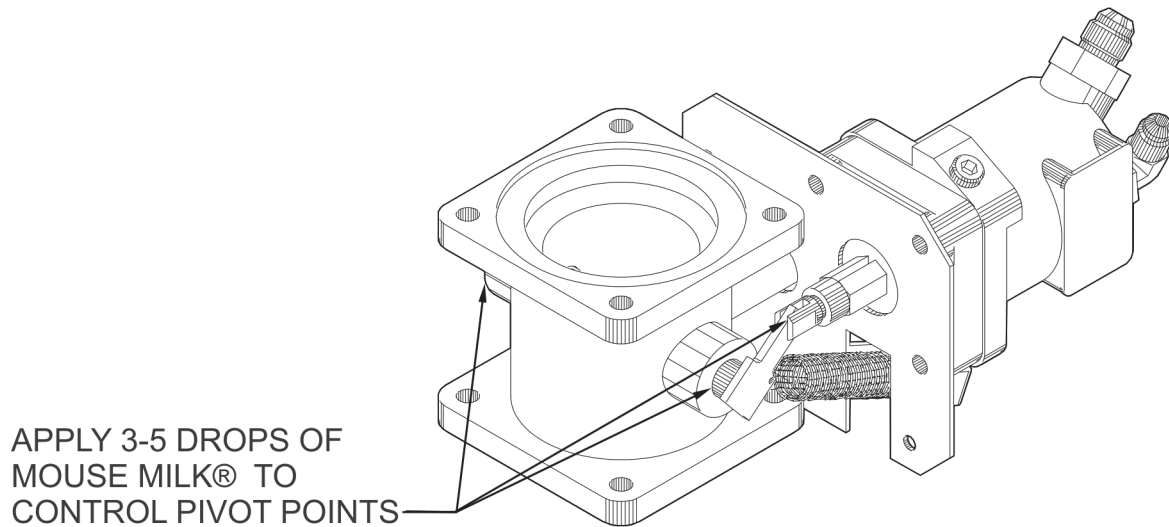

Figure 6-97.1. Typical Wastegate Lubrication Points

20. For applicable engine models: remove, disassemble, and inspect the turbocharger oil supply check valve according to the instructions in Section 6-4.21.1.

procedure continues on next page...

21. Inspect the wastegate controller and fittings for physical condition and security. If the wastegate controller exhibits physical damage, replace the wastegate controller with a new, rebuilt, or serviceable unit. Inspect the wastegate controller hoses, or tubes, for chafing, nicks, cuts or leaks; replace hoses exhibiting these conditions. Inspect the wastegate controller reference hoses or tubes for bends, dents, nicks or leaks; replace reference lines exhibiting these conditions.
22. Inspect the wastegate controller (Figure 6-56) housing for oil leaks around the diaphragm, deck pressure sensing port, oil inlet, oil outlet, or adjustment screw. If oil is leaking from a fitting, remove the fitting and replace O-rings, install and torque the fitting to Appendix B specifications. If oil is leaking from the housing, replace the wastegate controller with a new, rebuilt, or serviceable unit.

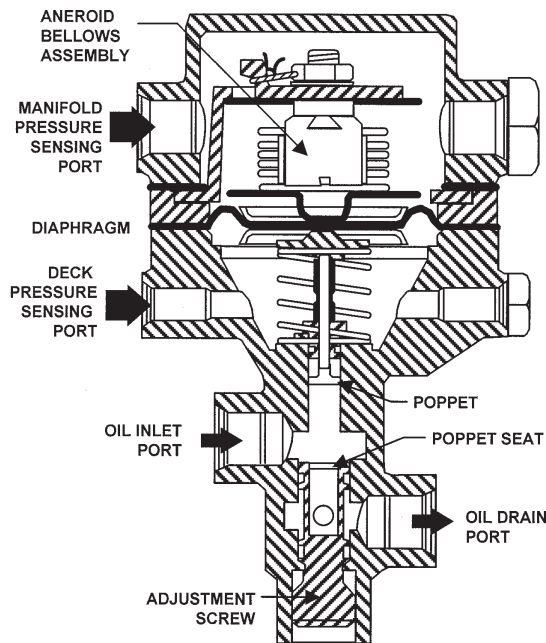

Figure 6-56 repeated for reference (typical sloped controller)

23. Inspect the overboost valve housing for cracks or physical damage; replace cracked or damaged overboost valve assembly with a new, rebuilt or serviceable unit. Remove accumulated debris from the overboost valve exposed bellows assembly shaft (behind the housing flange) and housing according to instructions in the primary ICA (**Ref: Section 1-1.1**). Inspect the mounting flange for fastener security; replace missing fasteners; re-torque loose overboost valve fasteners to Appendix B specifications.
24. Inspect the compressor housing V-band clamp, exhaust housing bolts and lock tabs for security. Torque loose hardware to Appendix B specifications.
25. Reassemble the turbocharger and exhaust system.
 - a. Install the induction system air supply according to aircraft manufacturer's instructions.
 - b. Install the turbocharger compressor discharge duct and exhaust pipe/heater muff according to the instructions in the primary ICA (**Ref: Section 1-1.1**) or the aircraft maintenance manual.



6-4.21.1. Turbocharger Oil Supply Check Valve Inspection

**Applicable Engines: TSIO-520-BE, LB, UB, WB;
TSIO-550-A, B, C, E, G, K, N;
TSIOF-550-D, J, K, P;
TSIOL-550-B, C**

The check valve is designed to prevent oil flow from the engine oil cooler to the turbocharger when the engine is shut down. If the check valve does not close properly, or becomes blocked with foreign matter, the check valve may remain open, allowing oil to continuously flow to the turbocharger (usually accompanied by oil puddling below the turbocharger).

Purpose

Inspect, clean and lubricate the check valve.

Procedure

1. Disconnect oil hose from the oil cooler at the check valve.
2. Disconnect check valve (where applicable) from:
 - a. hose servicing turbocharger (see Figure 6-97.3), or
 - b. tee fitting (Figure 6-97.4).

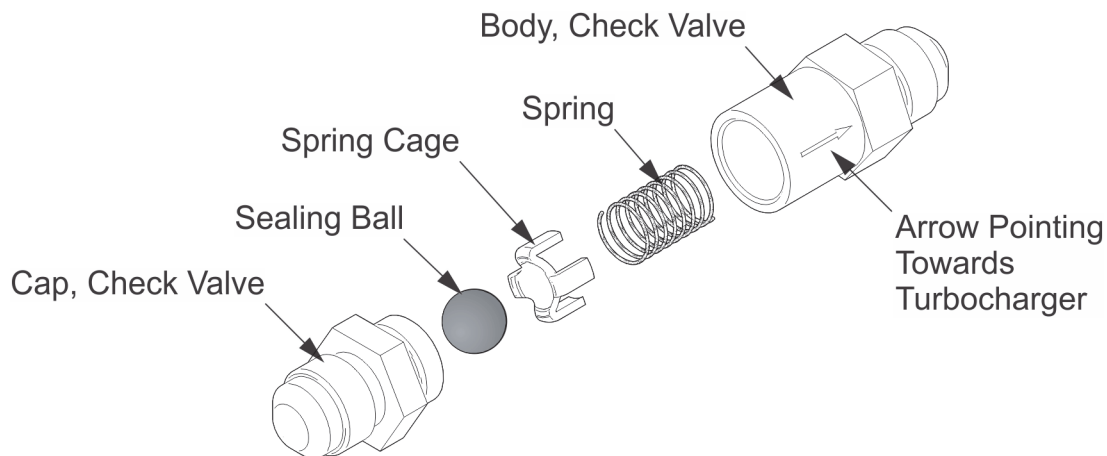

Figure 6-97.2. Check Valve Detail Illustration

3. To disassemble the check valve (see Figure 6-97.2), unscrew the check valve cap from the check valve body. Remove the sealing ball, spring cage, and spring.

CAUTION: Do not use metal cleaning tools such as brass or wire brushes or steel wool to clean the check valve.

4. In a clean container, clean check valve and all components with mineral spirits.

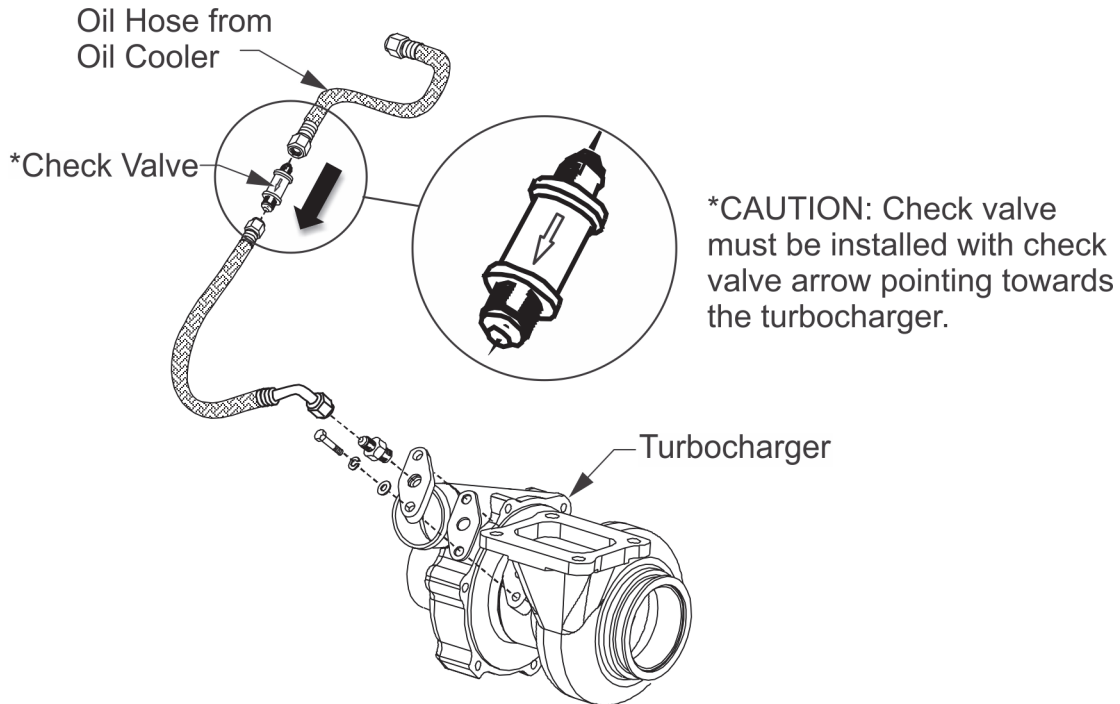

Figure 6-97.3. Single Turbocharger Lubrication (check valve location, typical)

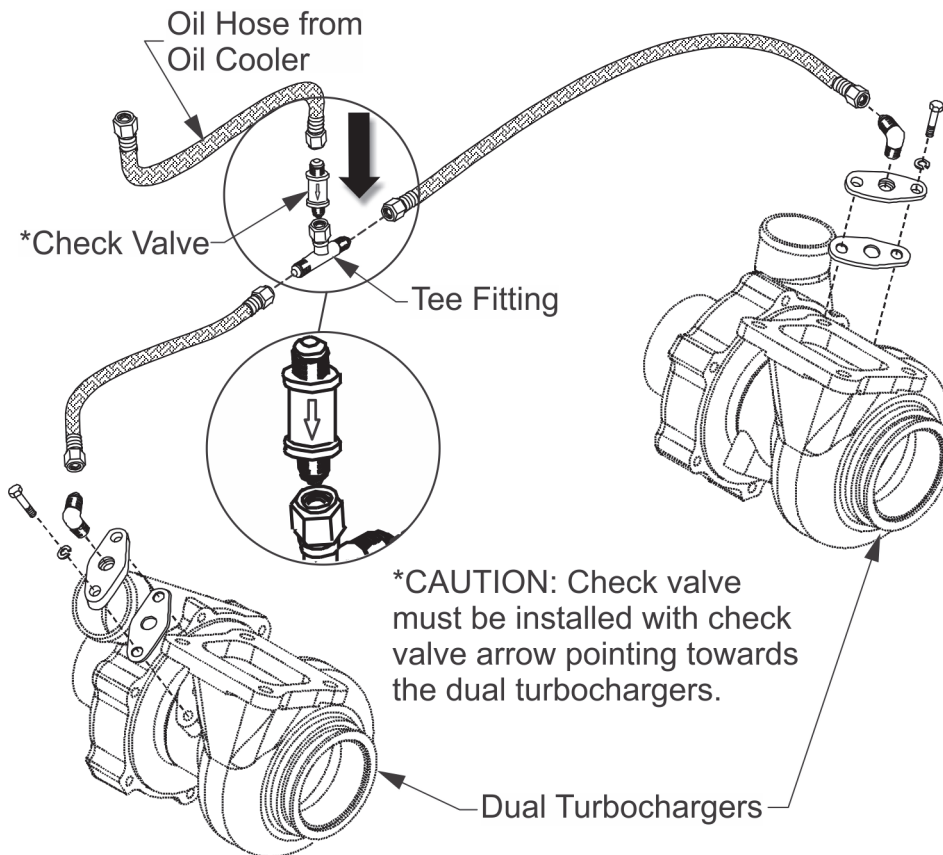

Figure 6-97.4. Dual Turbocharger (check valve location, typical)



5. Completely dry the body of the check valve with compressed air.
6. Inspect the check valve and all components for debris, corrosion, or physical damage. If damage is found, replace the entire check valve according to the Maintenance and Overhaul Manual instructions. If no damage is found, proceed to next step.
7. Apply a light coating of 50-weight aviation oil to all components and threads of check valve body and cap.

CAUTION: Do not force or cross-thread the check valve cap into the check valve body. Misaligning the internal components could cause the check valve to malfunction and hinder turbocharger lubrication.

8. Assemble the check valve (see Figure 6-97.2, for correct orientation):
 - a. Stack the spring, spring cage, and sealing ball and properly seat these internal components in the check valve body.
 - b. Insert the check valve cap squarely over the check valve body and tighten until the sealing surfaces make finger tight contact.

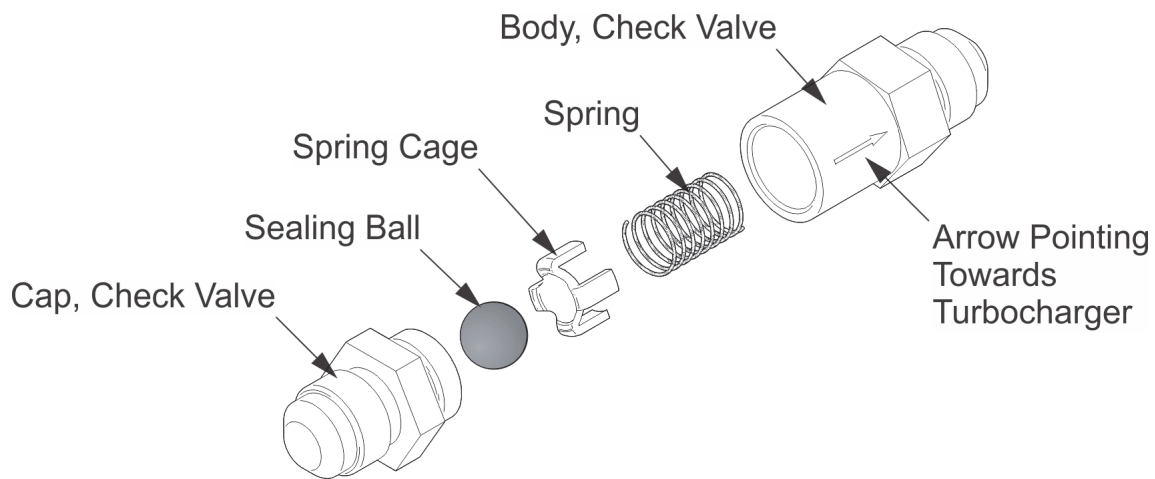
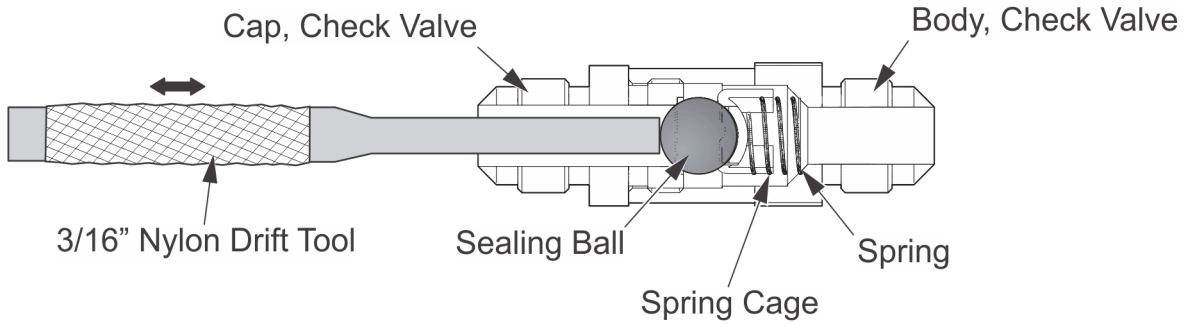

Figure 6-97.2 repeated for reference

CAUTION: Do not use sharp metal tools to verify movement of internal components, as it may damage the check valve's operation.

- c. Carefully insert a clean 3/16" nylon (or equivalent) drift tool into the check valve (as shown in Figure 6-97.5). Use light pressure to verify free, unobstructed movement of the internal components. Normal travel is approximately 0.06 inch.



Note: Gently insert drift tool and verify free movement of internal components

Figure 6-97.5. Check Valve Functional Check

- d. Torque the check valve cap and body to 100-150 in.-lbs and repeat step 8, c.

CAUTION: Check valve must be installed with the check valve arrow pointing towards the turbocharger (see Figure 6-97.3 or Figure 6-97.4). If the check valve is installed improperly it will cause the check valve to malfunction and prevent turbocharger lubrication.
9. Connect check valve (with the check valve arrow pointing towards the turbocharger) to:
 - a. hose servicing turbocharger and torque to 150-195 in.-lbs. (reference Figure 6-97.3), or
 - b. tee fitting and torque to 150-195 in.-lbs. (reference Figure 6-97.4).
10. Connect the oil hose from the oil cooler to the check valve and tighten nut finger tight. Torque hose fittings to 150-195 in.-lbs.
11. Replenish engine oil levels according to the instructions in Section 6-4.8.
12. Perform a “Ground Run-up”; check for oil leaks and correct any discrepancies.



Intentionally Left Blank



6-4.22. Alternator Inspection

Frequency

During 500-hour inspection

Procedure

1. Remove engine cowling and aircraft components necessary to gain access to the alternator.
2. Remove the alternator according to instructions in Section 10-4.1.1 or Section 10-4.1.1.1. Perform the “Alternator Drive Hub Inspection” in Section 6-4.22.1 or Section 6-4.22.2 on all gear driven alternators. For belt driven alternator removal, refer to the engine primary ICA (**Ref: Section 1-1.1**).
3. Inspect Continental Motors alternators according to the Alternator Service Manual (“Related Publications” in Section 1-2.5); correct any discrepancies discovered during the inspection. For engines equipped with Hartzell (Kelly) ES10024 consult Hartzell Service Information Letter A-135 for one time inspection requirements. For engines equipped with Hartzell (Kelly) ES-6012 or ES7024 belt driven alternators, consult Hartzell Service Information Letters A-137 and A-138 for one time inspection requirements. For additional instructions regarding Hartzell alternator instructions for continued airworthiness, consult Section 10-4.3. Remove and replace all other alternators with a new, rebuilt or serviceable alternators.
4. Install the serviceable alternator according to “Gear Driven Alternator Replacement, Forward Mount” in Section 10-4.1 or “Gear Driven Alternator Replacement, Aft Mount” in Section 10-4.2 after successfully completing the alternator manufacturer's service and inspection requirements. For belt driven alternator installation, refer to the engine primary ICA (**Ref: Section 1-1.1**).
5. Perform the instructions in the normal “Engine Start” (Section 7-3.2) and “Ground Run-up” (Section 7-3.3) to verify alternator operation.
6. Install airframe components and cowling according to the aircraft manufacturer's instructions.

6-4.22.1. Alternator Drive Hub Inspection **FWD**

Applicable Engines:

GTSIO-520-C, D, F, H, K, L, M, N, IO-520-B, BA, BB, C, CB, M, MB, NB, TSIO-520-B, BB, BE, D, DB, E, EB, J, JB, K, KB, L, LB, N, NB, UB, VB, WB, IO-550-A, B, C, G, N, P, R, IOF-550-B, C, N, P, R, TSIO-550- B, C,E, G, K, N, TSIOF-550-D, J, K, P, TSIOL-550, A, B, C

NOTE: This procedure only applies to the direct drive alternator. The alternator drive hub is designed to slip when abnormal torque is required to rotate the alternator shaft.

Procedure

1. Remove the top spark plugs according to instructions in Section 6-4.9.2.
2. Remove the alternator according to the instructions in Section 10-4.2.1.



3. Perform a “Gear Tooth Inspection” according to instructions in Section 11-1.1 on the alternator drive hub gear and the crankshaft gear.
 - a. Rotate the crankshaft 360° in order to inspect the circumference of the face gear.

NOTE: If the alternator drive hub exhibits damage or missing material, perform a “Foreign Object Contamination Inspection” according to the instructions in Section 6-5.7. Remove the foreign material from the crankcase and perform a visual inspection to determine if surrounding components were damaged as a result of the component failure.
 - b. Inspect the drive hub gear teeth for damage or missing material. If damage to the drive hub clutch is suspect, or damage is obvious, perform a “Foreign Object Contamination Inspection” according to instructions in Section 6-5.7.
4. Remove the alternator drive hub according to instructions in Section 10-4.1.2, “Gear Driven Alternator Drive Hub Removal.”
5. Alternator couplings with a drive spring assembly were superseded in 1996 by the elastomer drive coupling. If the alternator is assembled with a drive spring assembly, remove the drive spring assembly and replace it with an elastomer drive coupling according to the instructions in Section 10-4.1.2 and Section 10-4.1.3.
6. Inspect the alternator drive coupling assembly for shearing or tearing of the elastomeric (rubber) element. Replace worn or damaged parts observed according to instructions in Section 10-4.1.3, “Alternator Drive Hub Installation.” Inspect the exterior of the alternator for evidence of oil leakage; consult the alternator service instructions for oil seal replacement instructions. If the oil seal cannot be replaced, replace the alternator according to instructions in Section 10-4.

CAUTION: Secure only the outer diameter of the drive hub assembly; allow the gear freedom of movement to prevent shearing the elastomer coupling.
7. Perform an “Alternator Drive Hub Slippage Inspection” according to the instructions in Section 10-4.1.4 on the elastomer drive coupling.
8. Install the serviceable drive hub on the alternator according to instructions in Section 10-4.1.3, “Alternator Drive Hub Installation.”
9. Install the top spark plugs according to instructions in Section 6-4.9.2.

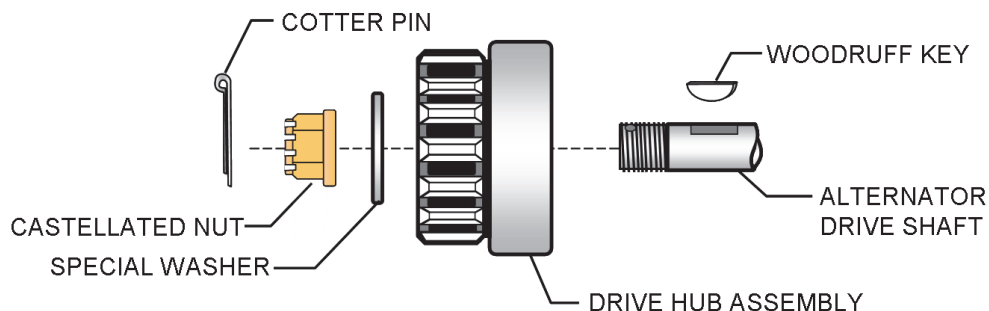

Figure 6-98. Alternator Drive Hub



6-4.22.2. Alternator Drive Hub Inspection **AFT**

Subject engines may have a single piece elastomer coupling or a multi-part coupling.

Applicable Engines:

C-75, C-85, C-90, C-115, C-125, C-145, E-165, E-185, E-225, O-200, GO-300, GIO-300, O-300, IO-240, IOF-240, IO-360, LTSIO-360, TSIO-360

NOTE: This procedure only applies to the direct drive alternator. The alternator drive hub is designed to slip when abnormal torque is required to rotate the alternator shaft.

Procedure

1. Remove the top spark plugs according to instructions in Section 6-4.9.2.
2. Remove the alternator from the accessory case according to the instructions in Section 10-4.2.1.
3. Perform a “Gear Tooth Inspection” according to instructions in Section 11-1.1 on the alternator drive hub gear and the camshaft gear.
 - a. Rotate the crankshaft through two complete revolutions while inspecting the circumference of the camshaft gear.
 - b. Inspect the drive hub gear teeth for damage or missing material. If damage to the drive hub is suspect, or damage is obvious, perform a “Foreign Object Contamination Inspection” according to instructions in Section 6-5.7.

4. Remove the alternator drive hub according to instructions in Section 10-4.2.2.

NOTE: If the alternator drive hub exhibits damage or missing material, perform a “Foreign Object Contamination Inspection” according to the instructions in Section 6-5.7. Remove the foreign material from the crankcase and perform a visual inspection to determine if surrounding components were damaged as a result of the component failure.

5. Identify the type of assembly installed and inspect the drive coupling.
 - a. Inspect the one piece alternator drive coupling assembly:
 - 1) Inspect the assembly for shearing or tearing; pay particular attention to the condition of the elastomeric (rubber) element. Replace the coupling if worn or damaged according to Section 10-4.2.2 and Section 10-4.2.3 instructions.

CAUTION: Secure only the outer diameter of the drive hub assembly; allow the gear freedom of movement to prevent shearing the elastomer coupling

- 2) Secure the alternator drive hub assembly in a vise with protective (padded) covers on the jaws. Do not over-tighten the coupling in the vise.
- 3) Install the Alternator Drive Hub Torque Tool (Figure 2-6) over the drive hub and apply 100 inch pounds of torque to the drive hub coupling with a calibrated torque wrench. No slippage is permitted at 100 inch pounds of



torque or less. Replace the drive hub if slippage occurs under 100 inch pounds of torque.

- 4) Install the serviceable drive hub on the alternator according to instructions in Section 10-4.2.3.

b. Inspect the multi-part drive coupling:

- 1) Secure the alternator coupling gear (Figure 6-99) (5) in the jaws of a padded vice, leaving the gear section free.

NOTE: At 500 Hours, replace the retainer and bushings regardless of condition, on the multi-piece couplings.

- 2) Remove the sleeve (6), bushings (8), and retainer (7). Do not remove the drive hub (1) unless damage is suspect. Discard the bushings (8) and retainer (7).
- 3) Inspect the nut (3), gear (5) and sleeve (6) for wear and replace if necessary.
- 4) Install a new retainer (7) and two new bushings (8) in the hub (1) on the alternator shaft. Install the sleeve (6) and gear (5) on the shaft and secure with the nut (3).
- 5) Install the drive hub assembly according to instructions in Section 10-4.2.3.

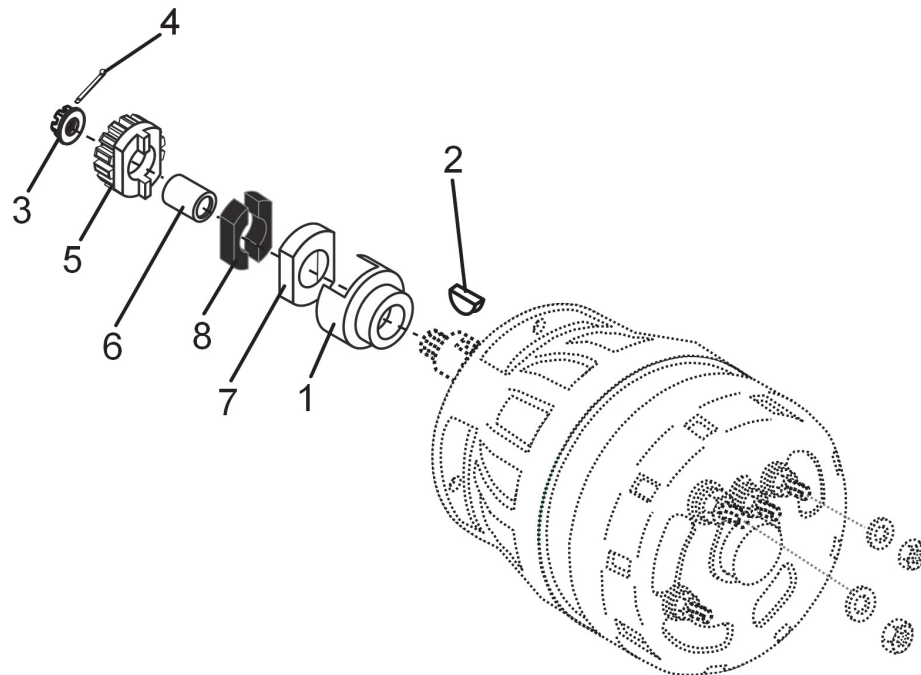

Figure 6-99. Alternator and Coupling Assembly

1	Drive Hub	3	Castellated Nut	5	Gear	7	Retainer
2	Woodruff Key	4	Cotter Pin	6	Sleeve	8	Bushings

6. Install the alternator according to instructions in Section 10-4.2.4.
7. Install the top spark plugs according to instructions in Section 6-4.9.2.



6-5. Unscheduled Maintenance

6-5.1. Propeller Strike

A propeller strike is any incident (whether or not the engine is operating) in which the propeller contacts a foreign object that 1) results in the necessity to repair the propeller blade(s) (other than minor blade dressing) or 2) results in loss of engine RPM at the time of contact. Propeller strikes can cause engine and component damage even if the propeller continues to rotate. This damage can result in catastrophic engine failure.

WARNING

Do not attempt to dress a propeller blade without consulting the propeller manufacturer's instructions. Stresses imposed on the propeller are more concentrated in areas that are nicked and cut. They may act as stress risers. Stress risers weaken the blade and can eventually cause the blade to fracture.

In cases where a small foreign object such as a small stone, strikes the propeller during operation, inspect and repair the propeller according to the propeller manufacturer's instructions. If foreign object damage requires removal of the propeller for repair(s) perform the "Propeller Strike Inspection" in Section 6-5.1.1.

6-5.1.1. Propeller Strike Inspection

Following any propeller strike, disassemble and inspect all rotating engine components prior to further flight; correct all unserviceable conditions. Inspect all engine driven components according to the manufacturer's instructions for continued airworthiness.

Procedure

1. Remove the propeller; inspect according to propeller manufacturer's instructions.
2. Remove the engine from the aircraft according to the instructions in Section 5-1.
3. Disassemble the engine completely according to instructions in the primary ICA (**Ref: Section 1-1.1**).
4. Regardless of condition, replace all counterweight pins, bushings, end plates and snap rings. Replace all connecting rod nuts and bolts, regardless of condition.
5. Thoroughly clean the crankshaft according to instructions in Chapter 12; all surfaces, especially those forward of the front main bearing, must be free of paint, sludge, or any substance that may mask cracks.
6. Perform a "Magnetic Particle Inspection" on the crankshaft, connecting rods, gears and remaining steel internal engine parts according to instructions in Section 11-3.
7. Strip the crankcase of all paint and clean the crankcase thoroughly according to instructions in Chapter 12; all surfaces must be free of paint, sludge, or any substance that may mask reliable inspection.
8. Perform a "Fluorescent Penetrant Inspection" on the crankcase according to instructions in Section 11-2, paying particular attention to the forward crankcase bearing support and adjacent structure.
9. Inspect the remainder of the engine according to the instructions in the primary ICA (Section 1-1.1).



10. Perform the aircraft inspections required by the aircraft manufacturer.
11. Inspect all engine accessories according to the manufacturer's instructions.
12. Assemble the engine according to instructions in the primary ICA (**Section 1-1.1**).
13. Install the engine in the aircraft according to the instructions in Section 5-2.

6-5.2. Hydraulic Lock Inspection

WARNING

Do not attempt to start an engine with an over-primed or flooded induction system. Starting an engine with a flooded induction system can result in hydraulic lock and subsequent engine malfunction or failure. Allow excess fuel to drain from the intake manifold and/or cylinder prior to attempting to start the engine.

In the event the operator starts an over-primed/flooded engine or suspects a hydraulic lock has occurred, perform the steps in the inspection procedure below.

Hydraulic lock occurs when fluid accumulates in the induction system or the cylinder assembly. The fluid restricts piston travel during the compression stroke. Engine damage occurs when the other cylinders fire, forcing the piston in the fluid filled cylinder through the compression stroke. Engine damage from hydraulic lock can be extensive due to the high stresses generated, which can adversely affect connecting rods, pistons, cylinder assemblies, piston pins, the crankcase, and crankshaft. Hydraulic lock may occur because of any of the following:

- Restricted or improperly maintained induction system or cylinder intake port drains
- Extended operation of electric boost pump
 - During failed engine start
 - Following loss of power during ground operation
 - Following momentary engine shutdown
 - During single engine operation for training purposes on twin engine aircraft
- Over priming and attempting engine start with the aircraft parked on an incline that negates the effective operation of the drain system
- Failure to properly remove preservative oil from an engine returned from storage

WARNING

Do not operate the engine if hydraulic lock is suspected.

Inspection Procedure

1. Remove the engine from the aircraft according to instructions in Section 5-1.
2. Disassemble the engine and remove all cylinders and connecting rods according to instructions in the primary ICA (**Section 1-1.1**).

procedure continues on next page...



Engine Inspection and Service

3. Perform a “Connecting Rod Magnetic Particle Inspection” according to the instructions in Section 11-3.1 and “Connecting Rod Dimensional Inspection” according to the instructions in the primary ICA (**Section 1-1.1**). If all connecting rods pass the inspection criteria, proceed to step 5, otherwise continue to step 4.

NOTE: Destroy the stressed parts to prevent future installation.

4. If any connecting rod fails the inspection criteria, disassemble the engine completely according to the instructions in the primary ICA (**Section 1-1.1**). Clean the crankcase, cylinders and pistons according to instructions in the Chapter 12. Perform Magnetic Particle, Fluorescent Penetrant and Ultrasonic Inspections, as appropriate, on the crankshaft, crankcase and cylinder parts according to instructions in Chapter 11. Perform the dimensional inspections for the crankcase and crankshaft according to instructions in the primary ICA (**Section 1-1.1**). Replace any part which fails the inspection criteria and destroy the faulty part(s).
5. Reassemble the engine according to instructions in primary ICA (**Section 1-1.1**).
6. Install the engine according to the instructions in Section 5-2.



6-5.3. Engine Overspeed Inspections

Operating an engine beyond its capacity can damage the engine and result in subsequent engine failure. Engine overspeed severity is divided into three categories in Table 6-25:

Table 6-25. Overspeed Categories

Engine Model	Rated RPM	Category (RPM)		
		I UP TO	II UP TO	III OVER
0-200, C-Series	2475-2800	3000	3300	3300
O-240, IO-240, IOF-240	2800	3000	3300	3300
0-300	2700	3000	3300	3300
GO-300	3200	3500	3700	3700
IO-346	2700	3000	3300	3300
IO-360, LTSIO-360, TSIO-360	2500-2800	3000	3300	3300
GIO-470	3200	3500	3700	3700
O-470, IO-470, TSIO-470	2400-2625	2900	3200	3200
GTSIO-520	3200-3400	3500	3700	3700
IO-520, LTSIO-520, TSIO-520	2400-2850	3000	3300	3300
IO-550, TSIO-550, TSIOF-550	2400-2850	3000	3300	3300
TIARA 6-285	4000	4100	4200	4200
TIARA 6-320	4400	4500	4600	4600
TSIOL-550	2600-2700	3000	3300	3300

NOTE: Rated RPM limits for aircraft equipped with digital RPM measuring equipment may be adjusted to include a +2% deviation for normal operations. Any operation beyond the rated RPM limit plus the 2% deviation must follow the inspection criteria.



6-5.3.1. Category I Overspeed Inspection

If the duration of the overspeed event is less than ten seconds, no action is required. If the overspeed event persists longer than 10 seconds, land the plane and perform the following inspection:

Procedure

1. Drain oil and inspect for debris. Remove the oil filter (or screen) and inspect the filter element for debris.
2. Remove the rocker covers and inspect the following for damage or debris:
 - a. Valves
 - b. Springs
 - c. Rocker arms
 - d. Tappets (lifters)
 - e. Spring retainers
 - f. Pushrods
3. Inspect components using the service limits in the primary ICA (Section 1-1.1); repair and assemble the engine components according to instructions in the primary ICA (Section 1-1.1).
4. Check accessory drives for excessive backlash.
5. Service the engine with new oil and oil filter according to instructions in 6-4.8.2.
6. If no discrepancies are noted, repeat step 1 after five hours of accumulated flight.

6-5.3.2. Category II Overspeed Inspection

If the overspeed event duration is less than ten seconds, perform the Category I Inspection and Service requirements specified in Section 6-5.3.1. If the overspeed event lasts longer than 10 seconds, land the plane and perform the following inspection:

Procedure

1. Complete Category I inspection and service requirements.
2. Remove all cylinder assemblies, including pistons and rods.
3. Remove all counterweights (if applicable) (on TIARA, inspect the VTC unit).
4. Replace all connecting rod nuts and bolts, regardless of condition. Inspect removed components using service limits and inspection instructions in the primary ICA (Section 1-1.1) and assemble the engine according to instructions in the primary ICA (Section 1-1.1).
5. If no discrepancies are noted, replace the engine oil and filter according to the instructions in Section 6-4.8 after five hours of accumulated flight.



6-5.3.3. Category III Overspeed Inspection

Overspeed conditions in this category are considered extreme. Category III overspeed cases must be evaluated based on factors at the time of the incident. A Continental Motors service representative (see “Contact Information” in Section 1-3) will assist in determining required actions to return the engine to an airworthy service condition.

Procedure

1. Remove the engine and clearly identify the reason for removal:

“Removed for excessive overspeed”

2. Perform a complete engine overhaul. Replace the following without regard to overhaul inspection limits:
 - a. Connecting rods
 - b. Connecting rod bolts and nuts
 - c. All valve train components

6-5.4. Turbocharger Overboost

Erratic throttle movement, especially during takeoff and landing may cause the turbocharger to exceed engine manifold pressure limits, a condition referred to as “overboost.” For overboost below 3 in. Hg, slower throttle movement will prevent future occurrences.

1. Turbocharger overboost events between 3 and 6 in. Hg indicate a hardware malfunction or improper control calibration. Troubleshoot the malfunction according to instructions in Section 8-10 and correct before further flight.
2. Turbocharger overboost in excess of 6 in. Hg is an indication of a serious malfunction. Engine damage is likely and must be assessed. Contact Continental Motors Customer Service Department for instructions. Be prepared to provide details of event, including the duration of the event and degree of overboost.



6-5.5. Lightning Strike Inspection

Procedure

1. Remove the engine(s) from the aircraft according to the instructions in Section 5-1.
2. Disassemble the engine(s) according to instructions in the primary ICA (**Ref: Section 1-1.1**).
3. Inspect the engine(s) for arcing and heat damage to the crankshaft rod journals, main journals, counterweights (if applicable), camshaft lobes, bearings, gear teeth, and all other hardened surfaces. Perform a “Magnetic Particle Inspection” according to instructions in Section 11-3 and degauss all steel parts of the engine(s) during the inspection.
4. Perform dimensional inspections on the remaining parts using the instructions and service limits in the primary ICA (**Ref: Section 1-1.1**). Replace all non-conforming parts.
5. Reassemble the engine(s) according to instructions and service limits in the primary ICA (**Ref: Section 1-1.1**).
6. Install the engine(s) according to instructions in Section 5-2.

6-5.6. Contaminated Fuel System Inspection

Engines described in this manual are certified for operation with the aviation fuel specifications listed in the Type Certificate Data Sheet (TCDS) located on the FAA web site. If the fuel tanks are filled with an improper grade of fuel but neither the aircraft boost pump nor the engine is operated with the improper grade of fuel, purge the fuel tanks according to the aircraft maintenance manual instructions. If the aircraft boost pump or the engine are operated with an incorrect grade of aviation fuel or jet fuel:

Procedure

1. Do not fly the aircraft.
2. Drain and purge the aircraft fuel system according to the aircraft manufacturer's instructions.
3. Remove the engine(s) from the aircraft according to the instructions in Section 5-1.
4. Disassemble, clean, and inspect the engine(s) according to instructions in the primary ICA (**Section 1-1.1**). Replace any cylinder, piston, piston pin, connecting rod or crankshaft exhibiting signs of detonation.
5. Reassemble and test the engine(s) according to instructions in the primary ICA (**Section 1-1.1**).
6. Install the engine(s) according to instructions in Section 5-2.



6-5.7. Foreign Object Contamination Inspection

Foreign Object Damage (FOD) occurs when material that wasn't included in the original design contacts (internally or externally) and contaminates the engine. FOD can increase friction, prohibit normal distance of travel, block oil passages, accelerate wear on contact surfaces or cause immediate catastrophic failure of components or the entire engine. FOD may be caused by external elements (i.e. sand, grit or metal shavings) or debris from fractured internal components such as an improperly torqued fasteners.

WARNING

Exercise strict housekeeping standards when performing aircraft and engine maintenance. Inventory tools before and after performing maintenance. When replacing engine parts, remove all remnants (safety wire, gasket material, o-rings, fragmented parts, etc.) of the removed part from the engine before installing the new part.

Procedure

1. Drain the engine oil and remove the oil sump from the crankcase.
2. Conduct a thorough inspection of the oil sump, crankcase, crankshaft, camshaft, cylinder walls and pistons for the presence of, or damage caused by foreign objects.
 - a. If damage is discovered or any portion of the foreign material is not accounted for: disassemble, clean, inspect, repair and assemble the engine according to instructions and service limits in the primary ICA (Section 1-1.1).

CAUTION: Disassemble and thoroughly inspect the entire engine before assembly and return to service following a foreign object contamination event. Minimum inspection requirements are provided in step b if the owner/operator determines no foreign material remains in the engine and elects to not perform a complete inspection. Continental Motors assumes no responsibility for engine operation or airworthiness after a contamination event.

- b. If 100% of the foreign material is retrieved from the oil sump and no further material is discovered, clean the sump according to “Engine Cleaning” instructions in the Chapter 12; install the oil sump, service the engine oil and return the engine to service. Perform the next three oil changes at ten hour intervals to confirm lack of foreign material in the oil.
3. Correct discrepancies discovered during the inspection. Do not return the engine to service until the contamination is eliminated and appropriate repairs are made to correct any discrepancies discovered during the inspection.



6-6. Inspection Checklists

Inspection checklists are included as a convenient record of inspection progress and findings. Using a copy of the form ensures a blank form will be available for the next scheduled inspection. When an inspection is due, make a copy of the inspection checklist to record inspection progress and findings while following the steps in the inspection procedures. The checklists are not designed to replace the procedures; only augment them. File the completed checklists in the aircraft records.



Table 6-26. Engine Operational Checklist																	
Aircraft Make & Model:								Aircraft Registration #:									
Engine Model:								Engine Position:		Left	Right	Front	Rear				
Engine Serial Number:								Engine Total Time:NewOverhaul									
Date		Location:						Elevation:		Outside Air Temp.:			Altitude:				
Operational Check																	
RPM		Magneto Drop Check			MAP		Cylinder Head Temp. - °F						EGT	TIT			
Spec	Actual	L	R	Drop/Spread	Spec	Actual	1	2	3	4	5	6	°F	°F			
Adjustments																	
IDLE Fuel Pressure (psi)				Full Power Fuel Pressure (psi)				Oil									
Spec	Actual	Adjustments		Spec	Actual	Adjustments		Pressure PSI	Temp. °F	Adjustments							
		CW	CCW			CW	CCW			CW	CCW						
Check Flight Data																	
RPM	MAP	Pressure Altitude		EGT °F		TIT °F		CHT °F									
		Set altimeter to 29.92"		Spec	Actual	Spec	Actual	Spec	Actual	Spec	Actual						
Fuel Flow				Oil PSI		Oil Temp. °F		Indicated Airspeed									
Spec		Actual		Spec	Actual	Spec	Actual										
Remarks:																	
Signature: _____																	



Intentionally Left Blank



Table 6-27. 25-Hour Initial Operation Inspection Checklist

Engine Model Number: _____ Engine Serial Number: _____

Total Time Engine has been in Service: _____

Time Since Major Overhaul (TSMOH): _____ Engine in Storage? _____

Date Inspection Performed: _____ Inspection Performed by: _____

Complete the 25-hour inspection according to the instructions referenced in the table, heeding all warnings, cautions and notes. Initial the block beside the procedure upon completion. Note discrepancies in the Inspector Comments or Remarks sections.

Inspection Item	Initials	Inspector Comments
"Visual Inspection" (Section 6-4.6)		
Check Oil Consumption (Section 6-4.2)		
"Induction System Inspection" (Section 6-4.14)		
"Induction System Drain Inspection"(Section 6-4.20)		
Change Engine Oil and Filter (Section 6-4.8.2)		
Engine Run (Section 7-3.2)		
•Idle RPM:		
•Idle Mixture Cutoff Rise		
•Acceleration		

Remarks:

Approval Block:



Intentionally Left Blank



Table 6-28. 50-Hour Engine Inspection Checklist		
Engine Model Number: _____ Engine Serial Number: _____		
Total Time Engine has been in Service: _____		
Time Since Major Overhaul (TSMOH): _____ Engine in Storage? _____		
Date Inspection Performed: _____ Inspection Performed by: _____		
Complete the 50-hour inspection according to the instructions referenced in the table, heeding all warnings, cautions and notes. Initial the block beside the procedure upon completion. Note discrepancies in the Inspector Comments or Remarks sections.		
Inspection Item	Initials	Inspector Comments
Oil Consumption and Trend Monitoring		
Collect oil sample (Section 6-4.8.4) and Establish Oil Analysis Profile (Section 6-4.8.5)		
Oil Analysis Laboratory used?		
Date of last oil sample analysis:		
Silicone content of last sample:		
Oil consumption quantity noted during oil change:		
Is oil consumption excessive? <input type="checkbox"/> Yes <input type="checkbox"/> No		
Visual Inspection		
"Visual Inspection" (Section 6-4.6)		
Oil and Filter Change (Section 6-4.8.2)		
"Induction System Inspection" (Section 6-4.14)		
"Induction System Drain Inspection" (Section 6-4.20)		
For specified turbocharged engines only, lubricate the wastegate butterfly valve (Section 6-4.21) and clean the turbocharger oil supply check valve (Section 6-4.21.1)		
Engine Run (Section 7-3.2)		
•Idle RPM:		
•Idle Mixture Cutoff Rise		
•Acceleration		
Remarks:		
Approval Block:		
Checklist Page 1 of 1		



Intentionally Left Blank



Table 6-29. 100-Hour Engine Inspection Checklist

Engine Model Number: _____ Engine Serial Number: _____		
Total Time Engine has been in Service: _____		
Time Since Major Overhaul (TSMOH): _____ Engine in Storage? _____		
Date Inspection Performed: _____ Inspection Performed by: _____		
Complete the 100-hour inspection according to the instructions referenced in the table, heeding all warnings, cautions and notes. Initial the block beside the procedure upon completion. Note discrepancies in the Inspector Comments or Remarks sections.		
Inspection Item	Initials	Inspector Comments
Engine Operational Check(Section 6-4.7)		
Oil Consumption and Trend Monitoring		
Oil Analysis Profile Established? (Section 6-4.8.5)		
Oil Analysis Laboratory used?		
Date of last oil sample analysis:		
Silicone content of last sample:		
Oil consumption quantity noted during oil change:		
Is oil consumption excessive? <input type="checkbox"/> Yes <input type="checkbox"/> No		
“Visual Inspection” (Section 6-4.6)		
Accessory Mounting and Security Inspection (Step 18 in Section 6-4.4)		
“Cylinder Inspections”(Section 6-4.11) using the Cylinder Inspection Checklist (Table 6-31 on page 171)		
“Crankcase Inspection”(Section 6-4.12)		
“Engine Mount Inspection” (Section 6-4.13)		
“Induction System Inspection” (Section 6-4.14)		
“Ignition System Inspection” (Section 6-4.15)		
“Engine Gauge Inspection” (Section 6-4.16)		
“Fuel System Inspection” (Section 6-4.17)		
“Engine Control Linkage Inspection” (Section 6-4.19)		
“Induction System Drain Inspection”(Section 6-4.20)		
“Turbocharger and Exhaust System Inspection” (Section 6-4.21)		
Page 1 of 2		



Table 6-30. 500-Hour Engine Inspection Checklist

Engine Model Number: _____ Engine Serial Number: _____		
Total Time Engine has been in Service: _____		
Time Since Major Overhaul (TSMOH): _____ Engine in Storage? _____		
Date Inspection Performed: _____ Inspection Performed by: _____		
Complete the 500-hour inspection according to the instructions referenced in the table, heeding all warnings, cautions and notes. Initial the block beside the procedure upon completion. Note discrepancies in the Inspector Comments or Remarks sections.		
Inspection Item	Initials	Inspector Comments
Engine Operational Check(Section 6-4.7)		
Oil Consumption and Trend Monitoring		
Oil Analysis Profile Established? (Section 6-4.8.5)		
Oil Analysis Laboratory used?		
Date of last oil sample analysis:		
Silicone content of last sample:		
Oil consumption quantity noted during oil change:		
Is oil consumption excessive? <input type="checkbox"/> Yes <input type="checkbox"/> No		
“Visual Inspection” (Section 6-4.6)		
Accessory Mounting and Security Inspection (Step 18 in Section 6-4.4)		
Paper Induction Filter Replacement (Section 6-4.5)		
“Cylinder Inspections”(Section 6-4.11) using the “Cylinder Inspection Checklist” (Table 6-31)		
“Crankcase Inspection”(Section 6-4.12)		
“Engine Mount Inspection” (Section 6-4.13)		
“Induction System Inspection” (Section 6-4.14)		
“Ignition System Inspection” (Section 6-4.15)		
500-Hour (Continental) Magneto Inspection or (non-Continental) Magneto Replacement (Section 6-4.15)		
“Engine Gauge Inspection” (Section 6-4.16)		
“Fuel System Inspection” (Section 6-4.17)		
Page 1 of 2		



Table 6-31. Cylinder Inspection Checklist

Engine Model Number: _____ **Engine Serial Number:** _____
Total Time Engine has been in Service: _____
Time Since Major Overhaul (TSMOH): _____ **Engine in Storage?** _____
Date Inspection Performed: _____ **Inspection Performed by:** _____

Inspection Item	Inspector Comments
-----------------	--------------------

Complete the cylinder inspection according to the instructions referenced in the table, heeding all warnings, cautions and notes. Initial the block beside the procedure upon completion. Note discrepancies in the Inspector Comments or Notes sections.

Complete a visual inspection of the cylinder exterior and power stroke areas for signs of cracks, leaks, rust or pitting (Section 6-4.11.1).

Cylinders					
1	2	3	4	5	6
<input type="checkbox"/>	<input type="checkbox"/>	<input type="checkbox"/>	<input type="checkbox"/>	<input type="checkbox"/>	<input type="checkbox"/>

Complete a visual inspection of cylinder head, barrel, fins, ports and bosses for evidence of fuel, oil or soot (Section 6-4.11.1)

Cylinders					
1	2	3	4	5	6
<input type="checkbox"/>	<input type="checkbox"/>	<input type="checkbox"/>	<input type="checkbox"/>	<input type="checkbox"/>	<input type="checkbox"/>

Inspect the cylinder to crankcase mounting deck for visible signs of RTV sealant (Section 6-4.11.4).

Cylinders					
1	2	3	4	5	6
<input type="checkbox"/>	<input type="checkbox"/>	<input type="checkbox"/>	<input type="checkbox"/>	<input type="checkbox"/>	<input type="checkbox"/>

Differential Pressure Check (Section 6-4.11.2)

Baseline Master Orifice Calibrated Pressure Reading:					
Cylinder Pressure Reading					
1	2	3	4	5	6
<input type="checkbox"/>	<input type="checkbox"/>	<input type="checkbox"/>	<input type="checkbox"/>	<input type="checkbox"/>	<input type="checkbox"/>

NOTES:



Table 6-31. Cylinder Inspection Checklist

Engine Model Number: _____ Engine Serial Number: _____						
Total Time Engine has been in Service: _____						
Time Since Major Overhaul (TSMOH): _____ Engine in Storage? _____						
Date Inspection Performed: _____ Inspection Performed by: _____						
Cylinder Borescope Findings (Section 6-4.11.3)						
Place a check mark in the column of any cylinder exhibiting the characteristics described in the left column.						
Condition	1	2	3	4	5	6
Normal Wear.	<input type="checkbox"/>	<input type="checkbox"/>	<input type="checkbox"/>	<input type="checkbox"/>	<input type="checkbox"/>	<input type="checkbox"/>
Light Rust (acceptable in absence of excessive oil consumption or leaks)	<input type="checkbox"/>	<input type="checkbox"/>	<input type="checkbox"/>	<input type="checkbox"/>	<input type="checkbox"/>	<input type="checkbox"/>
Small areas of heavy rust (less than ½ inch diameter)	<input type="checkbox"/>	<input type="checkbox"/>	<input type="checkbox"/>	<input type="checkbox"/>	<input type="checkbox"/>	<input type="checkbox"/>
Heavy rust (greater than ½ inch)	<input type="checkbox"/>	<input type="checkbox"/>	<input type="checkbox"/>	<input type="checkbox"/>	<input type="checkbox"/>	<input type="checkbox"/>
Pitting of on cylinder wall.	<input type="checkbox"/>	<input type="checkbox"/>	<input type="checkbox"/>	<input type="checkbox"/>	<input type="checkbox"/>	<input type="checkbox"/>
Heavy wear	<input type="checkbox"/>	<input type="checkbox"/>	<input type="checkbox"/>	<input type="checkbox"/>	<input type="checkbox"/>	<input type="checkbox"/>
Scoring	<input type="checkbox"/>	<input type="checkbox"/>	<input type="checkbox"/>	<input type="checkbox"/>	<input type="checkbox"/>	<input type="checkbox"/>
Static seal leakage	<input type="checkbox"/>	<input type="checkbox"/>	<input type="checkbox"/>	<input type="checkbox"/>	<input type="checkbox"/>	<input type="checkbox"/>
Other discrepancies	<input type="checkbox"/>	<input type="checkbox"/>	<input type="checkbox"/>	<input type="checkbox"/>	<input type="checkbox"/>	<input type="checkbox"/>
Cylinder Inspection Summary						
Place a check mark in the column of any cylinder exhibiting the characteristics described in the left column. Cylinders exhibiting the following characteristics must be removed and repaired or replaced according to the instructions in Section 10-6, "Cylinder Repairs."						
Condition	1	2	3	4	5	6
Heavy rust, characterized by pitting of the cylinder wall	<input type="checkbox"/>	<input type="checkbox"/>	<input type="checkbox"/>	<input type="checkbox"/>	<input type="checkbox"/>	<input type="checkbox"/>
Scoring or scratches in the honed surface of the cylinder wall (or bore)	<input type="checkbox"/>	<input type="checkbox"/>	<input type="checkbox"/>	<input type="checkbox"/>	<input type="checkbox"/>	<input type="checkbox"/>
Blistered paint on the cylinder barrel/other evidence of excessive wear and internal heat	<input type="checkbox"/>	<input type="checkbox"/>	<input type="checkbox"/>	<input type="checkbox"/>	<input type="checkbox"/>	<input type="checkbox"/>
Cylinder subjected to overheating/detonation/piston scoring or piston pin damage to the cylinder bore.	<input type="checkbox"/>	<input type="checkbox"/>	<input type="checkbox"/>	<input type="checkbox"/>	<input type="checkbox"/>	<input type="checkbox"/>
Cylinder with radial fin crack extending to the root of a fin	<input type="checkbox"/>	<input type="checkbox"/>	<input type="checkbox"/>	<input type="checkbox"/>	<input type="checkbox"/>	<input type="checkbox"/>
Cylinder with barrel fin crack	<input type="checkbox"/>	<input type="checkbox"/>	<input type="checkbox"/>	<input type="checkbox"/>	<input type="checkbox"/>	<input type="checkbox"/>
Cylinder head turned in relation to barrel flange	<input type="checkbox"/>	<input type="checkbox"/>	<input type="checkbox"/>	<input type="checkbox"/>	<input type="checkbox"/>	<input type="checkbox"/>
Page 2 of 3						



Intentionally Left Blank



Chapter 7. Engine Operation

7-1. Introduction

This chapter contains the engine ground operating instructions applicable to all engines to facilitate maintenance personnel during:

- Normal Engine Operation
- Engine Operation in Abnormal Environments

Instructions in this chapter apply to Continental Motors engines conforming to the original type design and supplements information in the Airplane Flight Manual (AFM) or Pilot's Operating Handbook (POH) provided by the aircraft manufacturer or supplemental type certificate holder as required by the Federal Aviation Regulations (FAR) for aircraft operating procedures.

CAUTION: This chapter pertains to engine operations under various operating conditions. Normal operating instructions are presented first followed by operation in adverse operating environments.

7-2. Flight Prerequisites

If the engine is newly installed and/or has been repaired/overhauled, perform an “Engine Operational Check” according to instructions in Section 6-4.7 prior to releasing the engine for normal operation.

WARNING

DO NOT FLY THE AIRCRAFT UNTIL ALL FLIGHT PREREQUISITES HAVE BEEN MET.

The “Engine Operational Check” in Section 6-4.7 must be completed on an engine that has been installed, inspected, repaired, or overhauled before the aircraft can be released for normal operation.

NOTE: Environmental conditions (humidity), seasonal changes, and engine usage influence susceptibility to corrosion. Engines that are flown occasionally (less than one time per week) are more vulnerable to corrosion under these conditions. The best method of reducing the risk of corrosion is to fly the aircraft weekly for at least one hour. The owner/operator is ultimately responsible for recognizing corrosion and taking appropriate corrective action.

After successful completion of the Engine Operational Check, perform a Flight Check according to instructions in Section 7-2.4.2.

7-2.1. Oil Change Interval

NOTE: After the first 25 hours of operation, perform an oil change according to the “Engine Oil Servicing” instructions in Section 6-4.8.

The Oil Change Interval is specified in Table 6-2, “Engine Inspection and Maintenance Schedule.”



7-2.2. Engine Fuel Requirements

WARNING

Aircraft engines are certified for operation with specific aviation fuels. Authorized fuels are recorded on the engine Type Certificate Data Sheet (TCDS). If the minimum fuel grade is not available, use the next higher grade. Never use a lower grade fuel. The use of lower octane fuel may result in damage to, or destruction of, an engine. Any engine operating on fuel of a lower grade than approved by the engine type certificate must be completely disassembled for inspection.

WARNING

Continental Motors does not recommend or authorize the use of automotive fuels in aircraft engines. The engine warranty and pro rata policy will be voided if such fuels are utilized.

The fuel used in aircraft and aircraft engines is an integral part of the certification process. Service the aircraft only according to the instructions in the AFM/POH, which are based on the engine fuel specifications authorized by the TCDS. Some engines were certified for operation with fuel grades that are no longer available. A complete list of certified engines and the fuels authorized for operation, by engine model, is provided in Table 7-2. If the aircraft is inadvertently serviced with the incorrect grade of aviation fuel or jet fuel, the fuel system must be completely drained and the fuel tanks serviced in accordance with the aircraft manufacturer's recommendations. The use of automotive fuels is prohibited in all Continental Motors aircraft engines. After the fuel system is decontaminated, inspect the engine according to "Contaminated Fuel System Inspection" instructions in Section 6-5.6.

CAUTION: Follow the aircraft manufacturer's instructions applicable to the use of fuel additives.

Under certain ambient conditions of temperature and humidity, sufficient quantities of water may exist in the fuel to create restrictive ice formation in the fuel supply. To alleviate this occurrence, it is permitted to add no more than three percent Isopropyl Alcohol¹ or Diethylene Glycol Monomethyl Ether (DiEGME) conforming to military specification MIL-DTL-85470B, if approved by the aircraft manufacturer, may be added to the fuel supply for this purpose. Refer to Section 3-3.

Aviation Fuel Specifications are regulated by both International and National regulations. In the United States, the American Society for Testing and Materials (ASTM) is the basis for fuel specification. Some countries have bilateral agreements to accept and utilize the ASTM standards. While a comprehensive list of all countries' specifications is impractical for this manual, the regional specifications for which Continental Motors engines are certified are listed in Table 7-2.

1. Since isopropyl alcohol is normally added at the point of use, the operator is cautioned that it may impact octane performance. Depending on octane grade, the isopropyl alcohol additive may increase or decrease the fuel octane rating. Consult the respective fuel specification and the airframe manufacturer's instructions regarding fuel additives.



Table 7-1. Aviation Fuel Specifications

Fuel Specification	Fuel Grades	Color
ASTM D910 - Standard Specification for Aviation Gasolines	100 (100/130 ¹)	Green
	100LL	Blue
	100VLL	Blue
	80 (80/87 ¹)	Red
	91 (91/96 ¹)	Brown
ASTM D7547² - Standard Specification for Hydrocarbon Unleaded Aviation Gasoline	UL91	Colorless
GOST 1012 - Aviation Petrol Russian Federation of States	B95/130	Amber
	B91/115	Green
GB 1787 - Aviation Piston Engine Fuels People's Republic of China	95 (RH95/130)	Saffron
	100 (RH100/130)	

1. Inactive - consult the latest revision of ASTM D910.
2. Fuels meeting ASTM 7592 may be substituted - reference FAA SAIB HQ-16-05

NOTE: All certified Continental Motors engines previously certified for operation with 91/96 octane or grade 100/130 aviation gasoline will operate satisfactorily on Grade 100LL. It is recommended that Grade 100LL be used in these engines because of the reduction in combustion chamber deposits realized with the lower tetraethyl lead content.

Table 7-2. Authorized Fuels by Aircraft Model

Engine Model	Certified Fuel on Type Certificate	Current Alternate Authorization
NOTE: Engine operation with RH95/130 and UL94 fuel may limit engine performance, operating ceiling, and/or maximum recommended cruise power. Consult the engine specifications and operating limits section of the primary ICA for amplification.		
A-65, A-75	80/87	100LL
C-75, C-85, C-90, C-125, C-145	80/87	100LL
E-165, E-185, E-225	80/87	100LL
O-200-A, B	80/87	100LL
O-200-D, X	100/100LL, RH100/130	N/A
IO-240-A, B	100/100LL, B95/130, RH95/130	N/A
IOF-240-B	100/100LL, B95/130, RH95/130	N/A
O-300, GO-300	80/87	100LL
IO-360-A, AB, C, CB, D, DB, E, ES, G, GB, H, HB, J, JB, K, KB	100/100LL, B95/130, RH95/130	N/A
IO-360-B	80/87	100/100LL



Table 7-2. Authorized Fuels by Aircraft Model

Engine Model	Certified Fuel on Type Certificate	Current Alternate Authorization
NOTE: Engine operation with RH95/130 and UL94 fuel may limit engine performance, operating ceiling, and/or maximum recommended cruise power. Consult the engine specifications and operating limits section of the primary ICA for amplification.		
IO-360-AF	100/100LL/100VLL, UL91, UL94, B95/130, RH95/130	N/A
TSIO-360-A, AB, B, BB, C, CB, D, DB, E, EB, F, FB, G, GB, H, HB, JB, KB, LB, MB, NB, PB, SB; LTSIO-360-E, EB, KB	100/100LL	N/A
TSIO-360-RB; LTSIO-360-RB	100/100LL, B95/130, RH95/130	N/A
IO-346	91/96	100/100LL
O-470-4, 11, 13, 15	80/87	100LL
O-470-A, F, J, K, L, R & S	80/87	100LL
O-470-B, G, H, M, N & P	91/96	100/100LL
O-470-T & U	100LL	100/100LL
LIO-470, IO-470-A, C, G, P & T	91/96	100/100LL
IO-470-D, E, F, H, L, M, N, S, U, V & VO GIO-470; TSIO-470	100/130	100/100LL
IO-520-A, B, BA, BB, C, CB, J, M, MB,	100/100LL, RH95/130, or B95/130	N/A
IO-520-D, E, F, K, L, N, NB	100/100LL, B95/130	N/A
GTSIO-520	100/130	100/100LL
LIO-520	100/100LL, B95/130	N/A
TSIO-520	100/130	100/100LL
TIARA 6-285, 6-320	100/130	100/100LL
IO-550-A, B, C, G, N, P & R; IOF-550-A, B, C, G, N, P & R	100/100LL, RH95/130, or B95/130	N/A
IO-550-D, E, F, L; IOF-550-D, E, F, L;	100/100LL, RH95/130, or B95/130	N/A
TSIO-550-A	100/100LL	N/A
TSIO-550-B	100/100LL, RH95/130, or B95/130	N/A
TSIO-550-C, E, G, N	100/100LL, RH95/130, or B95/130	N/A
TSIO-550-K	100/100LL, RH95/130, or B95/130, UL94	N/A



Table 7-2. Authorized Fuels by Aircraft Model

Engine Model	Certified Fuel on Type Certificate	Current Alternate Authorization
NOTE: Engine operation with RH95/130 and UL94 fuel may limit engine performance, operating ceiling, and/or maximum recommended cruise power. Consult the engine specifications and operating limits section of the primary ICA for amplification.		
TSIOF-550-D, J, K & P	100/100LL, RH95/130, or B95/130	N/A
TSIOL-550-A, B, C	100/100LL	N/A

Some older engine models, originally certified for use with 80/87 grade fuels, particularly low compression ratio engines may experience lead build-up or spark plug fouling as a result of the higher octane and lead content of 100/100LL. Engines most affected by the higher octane include the A-65, A-75, C-75, C-85, C-90, C-125, C-145, O-200, O-300 and GO-300 engine series. Compliance with the instructions in Section 10-6.10 on these engines will improve engine operation with the higher grade fuels.

Spark plug lead fouling increases when higher leaded fuels are used in engines originally certificated on 80/87 octane fuel. Such fouling can be reduced by more frequent spark plug cleaning and spark plug rotation. Fine wire spark plugs that are FAA approved for use in those engines listed may further alleviate fouling problems. In any case, the rotation of plugs every 50 hours of operation and cleaning/rotation every 100 hours is recommended. A ground run at 800 to 1000 RPM of 60 to 90 seconds duration just prior to shutdown will allow temperature stabilization and burn off of deposits accumulated during descent and taxiing. Mixture cutoff should be accomplished at this RPM without returning to idle.

Exhaust valve sticking can result from lead salt (sulfated ash) accumulation in the lubricating oil. It is recommended that regular 50 hour oil changes be implemented to reduce such accumulation. A few stuck exhaust valves have been reported where examination of the cylinder assembly revealed an exhaust leak between the exhaust elbow flange and the exhaust port face. This condition created localized cylinder head overheating and subsequent exhaust valve and guide distress. The exhaust system should be inspected every 100 hours and leaks corrected prior to continued engine operational service.

Refer to the mixture leaning procedures in the AFM/POH to limit lead accumulation on low compression engines originally certified for 80/87 octane fuel.



7-2.3. Engine Operation after Cylinder Replacement and/or Major Overhaul

NOTE: Instructions within this section apply to steel, nitrided, through-hardened, or chrome plated cylinders. For engine operating instructions with nickel silicon carbide (NiC3) plating, refer to the operating instructions in the latest revision of SB15-6.

Proper operation of the engine following cylinder replacement or major overhaul is extremely important. The following procedures should be followed to ensure that adequate lubrication is being provided to newly installed components and that the piston ring seating will occur as soon as possible.

1. Operation After Major Overhaul Utilizing an Engine Test Cell
 - a. Servicing and Pre-starting Procedures
 - 1) Service the lubricating system with mineral oil of the appropriate grade depending on ambient temperature (Section 3-1).
 - 2) Rotate the propeller by hand through several cycles with the spark plugs removed.
 - 3) Pre-oil the lubrication system using an external pre-oiling pressure system according to the instructions in Section 5-2.9. Spark plugs are installed during the pre-oiling instructions.
 - b. Test Cell Operational Procedure
 - 1) Perform the Post-Overhaul testing according to the instructions in the engine primary ICA (**Ref: Section 1-1.1**).
2. Operation After Major Overhaul Utilizing The Aircraft in Lieu of an Engine Test Cell.
 - a. The aircraft can be considered a suitable test stand for running-in overhauled engines contingent on the following conditions.
 - 1) Install Engine Cowling
 - 2) Each cylinder should be equipped with a temperature sensing device to monitor the head temperature. If the aircraft cylinder head temperature gauge monitors one cylinder, the following precaution must be adhered to:
During ground runs do not permit monitored head temperatures to exceed 400°F or oil temperature to exceed 200°F.
 - 3) The flight propeller may be used contingent on careful observation of cylinder temperatures. Head the aircraft into the wind for this test.
 - 4) Calibration of the aircraft engine instruments must be performed.
3. Engine Operation After Cylinder Overhaul or New Cylinder Installation
 - a. Engine Starting and Ground Operation

CAUTION: Corrosion preventive mineral oil MIL-C-6529 can be used but must not be used after the first 25 hours, or six months, whichever occurs first as this oil can cause coking with extended use.



- 1) Service the lubricating system with mineral oil of the appropriate grade depending on ambient temperature (Section 3-1).
- 2) Ensure all engine and cylinder baffling is serviceable and properly installed.
- 3) Cowl the engine. Start the engine and verify oil pressure rises to within the specified limits within 30 seconds.
- 4) Operate the engine at 750 RPM for one minute, gradually increasing toward 1000 RPM in three minutes. Check the magneto circuit for grounding prior to a normal shut-down. Allow the engine to cool adequately and then make a visual inspection for any irregularities.
- 5) Start the engine again and operate it at 750 RPM gradually increasing to 1500 RPM over a period of four minutes.
 - a) If the engine is equipped with a controllable pitch propeller, cycle the propeller allowing only a 100 RPM drop.
 - b) Return to the idle range and make adjustments to the idle mixture and RPM as required on carburetor engines and to the low unmetered fuel pressure, idle RPM and mixture on fuel injected engines.
 - c) Position the throttle to 1200 RPM to smooth the engine. Then perform an idle mixture rise check. For continuous flow fuel injection systems, refer to Section 6-4.7 for fuel system specifications. For engines equipped with carburetors, refer to the primary ICA.
 - d) Run engine up to full power for a period not to exceed 10 seconds. Visually inspect and correct any discrepancies. Check, and service the oil level, if required.
 - e) Install aircraft accessories and cowling according to the aircraft manufacturer's instructions.
- 6) Perform a "Flight Check" and "Engine Break-In" according to the instructions in Section 7-2.4.2 and Section 7-2.4.1.



7-2.4. Flight Check and Break-In

New and factory rebuilt Continental Motors engines are adjusted to meet engine specifications in a test cell prior to shipment. A flight check ensures the engine meets operational specifications after installation in the airframe and prior to release for normal service.

Perform an “Engine Operational Check” according to instructions in Section 6-4.7 and a normal preflight, engine start and ground run-up in accordance with the Airplane Flight Manual or Pilot's Operating Handbook (AFM/POH) *before* the A&P mechanic can approve the airplane for a Flight Check.

A flight check is required for engines with a standard fuel pump if rated, full power RPM cannot be verified during a ground run-up according to instructions in Section 7-2.4.2 after engine installation, inspection, fuel system repairs, or adjustments. Additionally, engines with an altitude compensating fuel pump require a “Flight Check” according to instructions in Section 7-2.4.2 after a significant change in geographic location from the last operational check (or if the auto-leaning function is suspect) and at twelve month intervals, in conjunction with the Annual/100-hour inspection.

Follow the protocol in Section 7-2.4.1 to complete the recommended break-in period.

7-2.4.1. Engine Break-In

CAUTION: High power ground operation resulting in cylinder and oil temperatures exceeding normal operating limits can be detrimental to cylinders, pistons, valves, and rings.

CAUTION: If Nickel-Carbide cylinders, follow the break-in instructions in SB15-6.

The recommended break-in period for Continental Motors engines is 25 hours. Adhere to the following instructions and the Engine Specifications and Operating Limits in the primary Instructions for Continued Airworthiness (Section 1-1.1) applicable to the engine model.

1. Conduct a normal engine start, ground run-up and take-off according to the AFM/POH.
2. Monitor a) engine RPM, b) fuel flow and pressure (if equipped), c) oil pressure and temperature, d) cylinder head temperature (if equipped), e) exhaust gas temperature (if equipped), and f) turbine inlet temperature (if equipped) to verify the engine is operating within the parameters specified in the primary Instructions for Continued Airworthiness (Section 1-1.1).
3. Reduce the engine speed to climb power according to the AFM/POH instructions. Maintain a shallow climb attitude to achieve optimum airspeed and cooling airflow.
4. At cruise altitude:
 - a. Maintain level flight cruise at 75% power with best power or richer mixture for the first hour of operation.



NOTE: Best power mixture setting is 100°-150°F (38°-66°C) rich of peak exhaust gas temperature. Adjust engine controls or aircraft attitude to ensure engine instrumentation operates within specifications.

- b. For the second and subsequent hours of flight, alternate cruise power settings between 65% and 75% power with appropriate best power mixture settings.

WARNING

Avoid long descents at high engine RPM to prevent undesirable engine cooling. If power must be reduced for long periods, adjust the propeller to minimum governing RPM to obtain desired performance levels. If outside air temperature is extremely cold, it may be desirable to increase drag to maintain engine power without gaining excess airspeed. Do not permit cylinder head temperature to drop below 300°F (149°C).

5. Descend at low cruise power settings. Avoid long descents or descents at cruise power RPM with manifold pressure below 18 in. Hg. If necessary, reduce engine RPM to the lower limit of the specified operating range to maintain sufficient manifold pressure. Carefully monitor engine instrumentation to maintain levels above the minimum specified cylinder head temperature and oil temperature.
6. Correct any discrepancies prior to releasing the aircraft for service.

7-2.4.2. Flight Check

Flight check instructions vary, depending on fuel system configuration. Normally aspirated engines with a carburetor, Continental Motors (CM) continuous flow fuel injection without altitude compensating fuel pump, or turbocharged engines regardless of fuel system configuration, perform the Flight Check according to the instructions in Section 7-2.4.2.1. Naturally aspirated engines with CM continuous flow fuel injection and altitude compensating fuel pump, follow the Flight Check instructions in Section 7-2.4.2.2. For FADEC equipped engines, refer to the flight check in the primary ICA.

7-2.4.2.1. Standard Flight Check Instructions

NOTE: The accuracy of tachometer and fuel flow indicating device (if equipped) is critical to the outcome of the flight check. Verify tachometer and flow meter accuracy according to the aircraft manufacturer's instructions prior to performing the flight check.

1. Conduct a normal engine start, ground run-up and take-off according to the AFM/POH.
2. Monitor a) engine RPM, b) fuel flow and pressure (if equipped), c) oil pressure and temperature, d) cylinder head temperature (if equipped), e) exhaust gas temperature (if equipped), and f) turbine inlet temperature (if equipped) to verify the engine is operating within the parameters specified in the AFM/POH.
3. If the engine fails to reach the rated, full throttle RPM during ground operations, ascend to cruise altitude (>2000 feet above field elevation) and verify the engine achieves full throttle, full rich rated RPM at cruise altitude and operates within the limits specified in the AFM/POH; if the engine meets full power, rated RPM,



proceed to step 4. If the aircraft indicated values fail to meet the published limits, repeat the Engine Operational Check and Flight Check.

WARNING

All abnormal conditions must be corrected prior to releasing the aircraft to normal operation.

4. Release the engine to normal service.

7-2.4.2.2. Flight Check for CM Continuous Flow Fuel Injection Systems with Altitude Compensating Fuel Pump

NOTE: For engines equipped with Bendix/Precision servo controlled Fuel Systems with automatic density controllers, consult the primary ICA or AFM/POH for Flight Check instructions.

NOTE: The accuracy of tachometer and fuel flow indicating device (if equipped) is critical to the outcome of the flight check. Verify tachometer and flow meter accuracy according to the aircraft manufacturer's instructions prior to performing the flight check.

1. Conduct a normal engine start, ground run-up and take-off according to the AFM/POH.
2. Monitor a) engine RPM, b) fuel flow and pressure (if equipped), c) oil pressure and temperature, d) cylinder head temperature (if equipped), e) exhaust gas temperature (if equipped) to verify the engine is operating according to the parameters specified in the AFM/POH.
3. Set altimeter to 29.92 in. Hg.
4. Navigate the aircraft to an area of low air traffic density. Ascend to the minimum pressure altitude which offers unobstructed straight and level flight within the altitude scale presented in the table applicable to the subject engine model shown in Section 7-2.4.2.3. Record the altitude and corresponding fuel flow at 1000 ft. intervals depicted in Section 7-2.4.2.3 charts on a copy of the "Engine Operational Checklist" on page 6-161 of this manual.

RESULT:

- a. If the engine RPM and full power fuel flow meet the specifications depicted in the Altitude Leaning Schedule for engines equipped with altitude compensating fuel pumps, proceed to step 5.
- b. If the engine fails to meet the operating specifications, repeat the "Engine Operational Check" in Section 6-3.7 and make necessary adjustments according to the "Fuel System Adjustment" and "Auto Leaning Schedule Adjustments" instructions in Section 6-3.10.2 and Section 6-3.10.3, respectively.

WARNING

All abnormal conditions must be corrected prior to releasing the aircraft to normal operation.

5. Release the engine to normal service.



7-2.4.2.3. Altitude Compensating Fuel System Auto-Leaning Schedules

**Table 7-3. IO-360-D/DB Engine Altitude Leaning Schedule
Full Throttle RPM, Full Rich Mixture @ 2800 RPM**

Pressure Altitude (Set Altimeter at 29.92 in. Hg.)	Fuel Flow (lbs/hr)		Fuel Flow (gals/hr)		Metered Fuel Pressure PSID	
	Min.	Max.	Min.	Max.	Min.	Max.
Sea Level	102.9	112.9	17.5	19.2	16.0	18.8
1,000	98.4	108.4	16.8	18.5	15.0	17.8
2,000	94.1	104.1	16.0	17.7	14.1	16.8
3,000	90.0	100.0	15.3	17.0	13.3	15.9
4,000	86.1	96.1	14.7	16.4	12.6	15.1
5,000	82.3	92.3	14.0	15.7	11.9	14.4
6,000	78.8	88.8	13.4	15.1	11.3	13.7
8,000	72.2	82.2	12.3	14.0	10.2	12.5
10,000	66.4	76.4	11.3	13.0	9.3	11.5
12,000	61.3	71.3	10.4	12.1	8.6	10.7
14,000	56.9	66.9	9.7	11.4	8.0	10.0
16,000	53.3	63.3	9.1	10.8	7.5	9.5

Gasoline = 5.87 lbs per gallon @ 70° F.
IO-360-DB installed in T-41 aircraft, Refer to Cessna SL81-2, dated July 1981 for amplified instructions

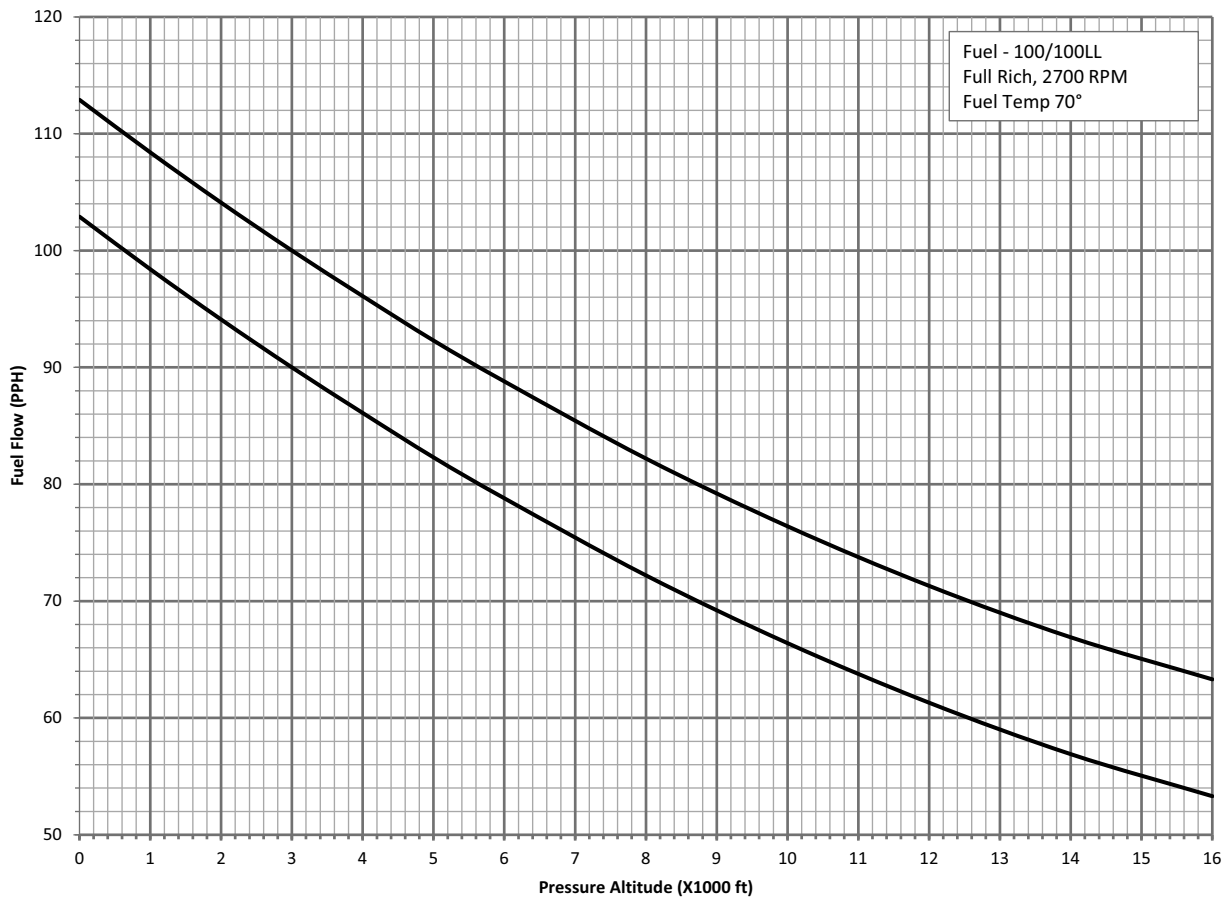

Figure 7-1. IO-360-D/DB Altitude Leaning Schedule



Table 7-4. IO-360-ES Engine Altitude Leaning Schedule
Full Throttle RPM, Full Rich Mixture @ 2800 RPM

Pressure Altitude (Set Altimeter at 29.92 in. Hg.)	Fuel Flow (lbs/hr)		Fuel Flow (gals/hr)		Metered Fuel Pressure PSID	
	Min.	Max.	Min.	Max.	Min.	Max.
Sea Level	100.0	107.0	17.0	18.1	14.3	16.5
1,000	97.7	103.7	16.6	17.7	13.9	15.8
2,000	93.7	99.7	16.0	17.0	13.1	14.9
3,000	93.3	96.3	15.4	16.4	12.3	14.1
4,000	87.3	93.3	14.9	15.9	11.7	13.6
5,000	85.0	91.0	14.5	15.5	11.5	13.2
6,000	83.3	89.3	14.2	15.2	11.1	12.8
8,000	80.0	86.0	13.6	14.7	10.6	12.2
10,000	77.3	83.3	13.2	14.2	10.1	11.8
12,000	74.4	80.4	12.7	13.7	9.6	11.2
14,000	71.3	77.3	12.1	13.2	9.2	10.7
16,000	69.3	75.3	11.8	12.8	8.9	10.3

Gasoline = 5.87 lbs per gallon @ 70° F.

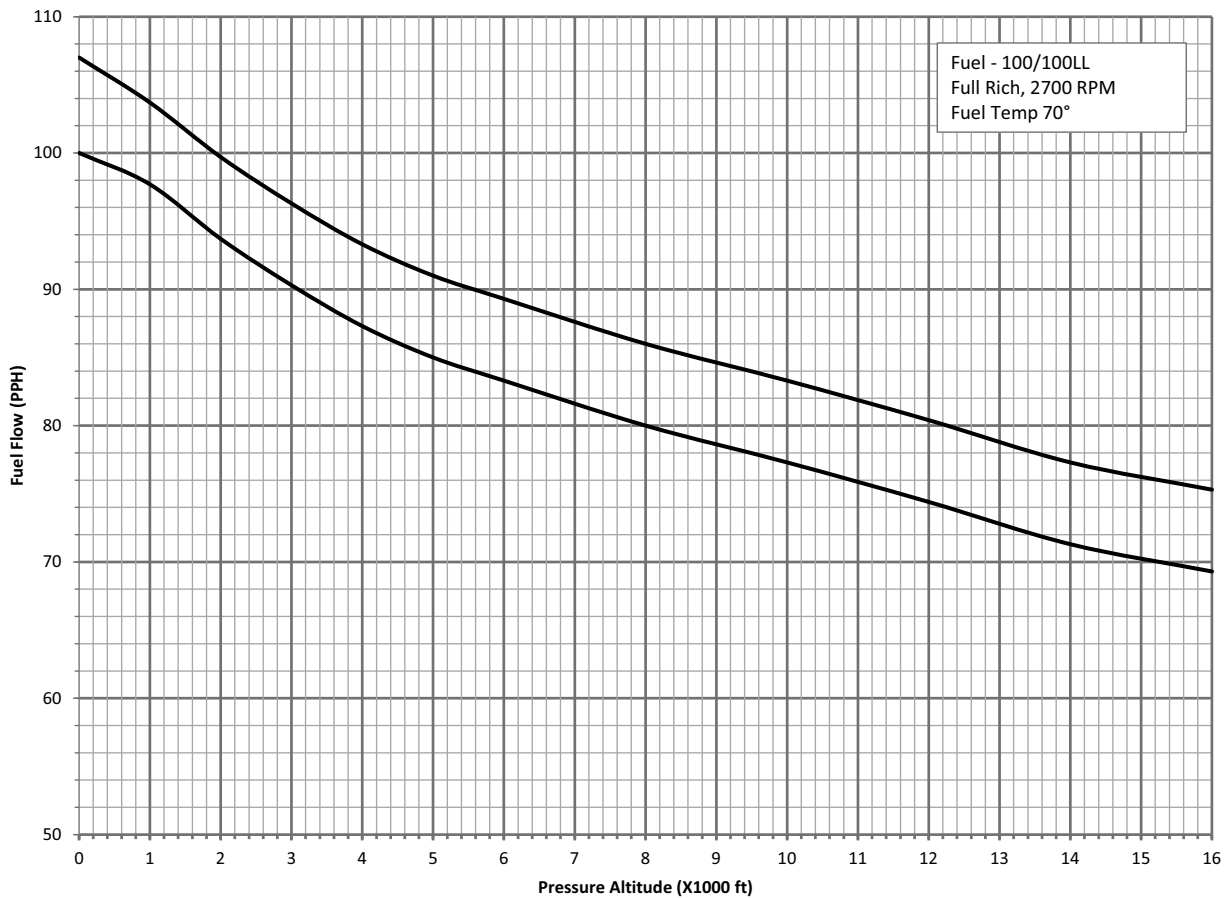

Figure 7-2. IO-360-ES Altitude Leaning Schedule



**Table 7-5. IO-360-ES (Cirrus SR20) Engine Altitude Leaning Schedule
Full Throttle RPM, Full Rich Mixture @ 2700 RPM**

Pressure Altitude (Set Altimeter at 29.92 in. Hg.)	Fuel Flow (lbs/hr)		Fuel Flow (gals/hr)		Metered Fuel Pressure PSID	
	Min.	Max.	Min.	Max.	Min.	Max.
Sea Level	96.0	102.0	16.4	17.4	13.8	15.5
1,000	94.5	99.7	16.0	17.0	13.3	15.0
2,000	89.5	95.7	15.3	16.3	12.5	14.2
3,000	86.3	92.3	14.7	15.7	11.9	13.5
4,000	83.3	89.3	14.2	15.2	11.4	13.0
5,000	81.0	87.0	13.8	14.8	11.0	12.5
6,000	79.3	85.3	13.5	14.5	10.7	12.2
8,000	76.0	82.0	12.9	14.0	10.2	11.7
10,000	73.3	79.3	12.5	13.5	9.7	11.2
12,000	70.4	76.4	12.0	13.0	9.3	10.7
14,000	67.3	73.3	11.5	12.5	8.8	10.2
16,000	65.3	71.3	11.1	12.1	8.6	9.9

Gasoline = 5.87 lbs per gallon @ 70° F.

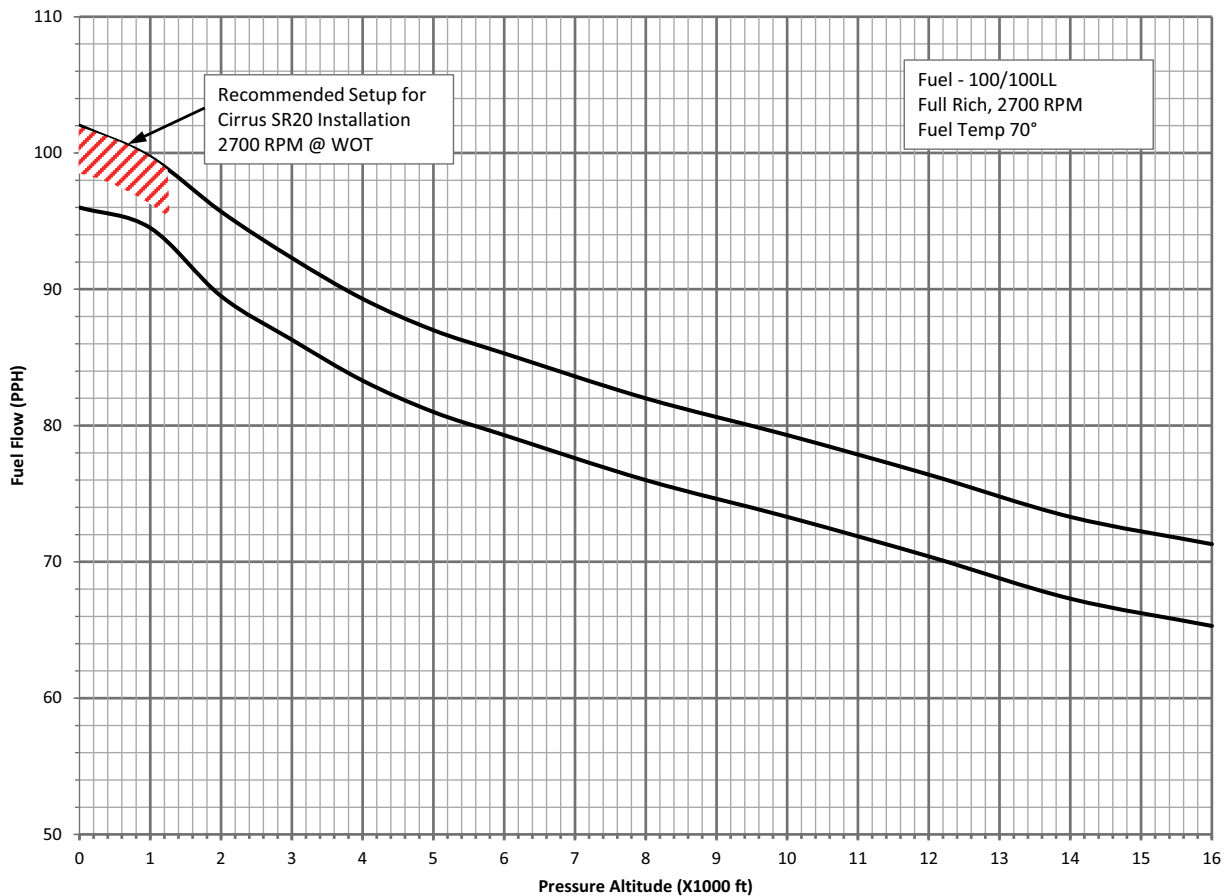

Figure 7-3. IO-360-ES in Cirrus SR20 Altitude Leaning Schedule



Table 7-6. IO-550-A Engine Altitude Leaning Schedule
Full Throttle RPM, Full Rich Mixture 300 BHP @ 2700 RPM

Pressure Altitude (Set Altimeter at 29.92 in. Hg.)	Fuel Flow (lbs/hr)		Fuel Flow (gals/hr)		Metered Fuel Pressure PSID	
	Min.	Max.	Min.	Max.	Min.	Max.
Sea Level	142	150	24.2	25.6	16.5	17.2
1,000	141	149	24.0	25.4	16.3	17.1
2,000	138	146	23.5	24.9	15.9	16.6
3,000	133	141	22.6	24.0	15.1	15.7
4,000	128	136	21.8	23.2	14.3	14.9
5,000	123	131	21.0	22.3	13.6	14.1
6,000	120	128	20.4	21.8	13.2	13.7
8,000	113	121	19.2	20.6	12.3	12.7
10,000	108	116	18.4	19.8	11.6	12.1
12,000	103	111	17.5	18.9	11.0	11.4
14,000	98	106	16.7	18.1	10.4	10.7

Gasoline = 5.87 lbs per gallon @ 70° F.

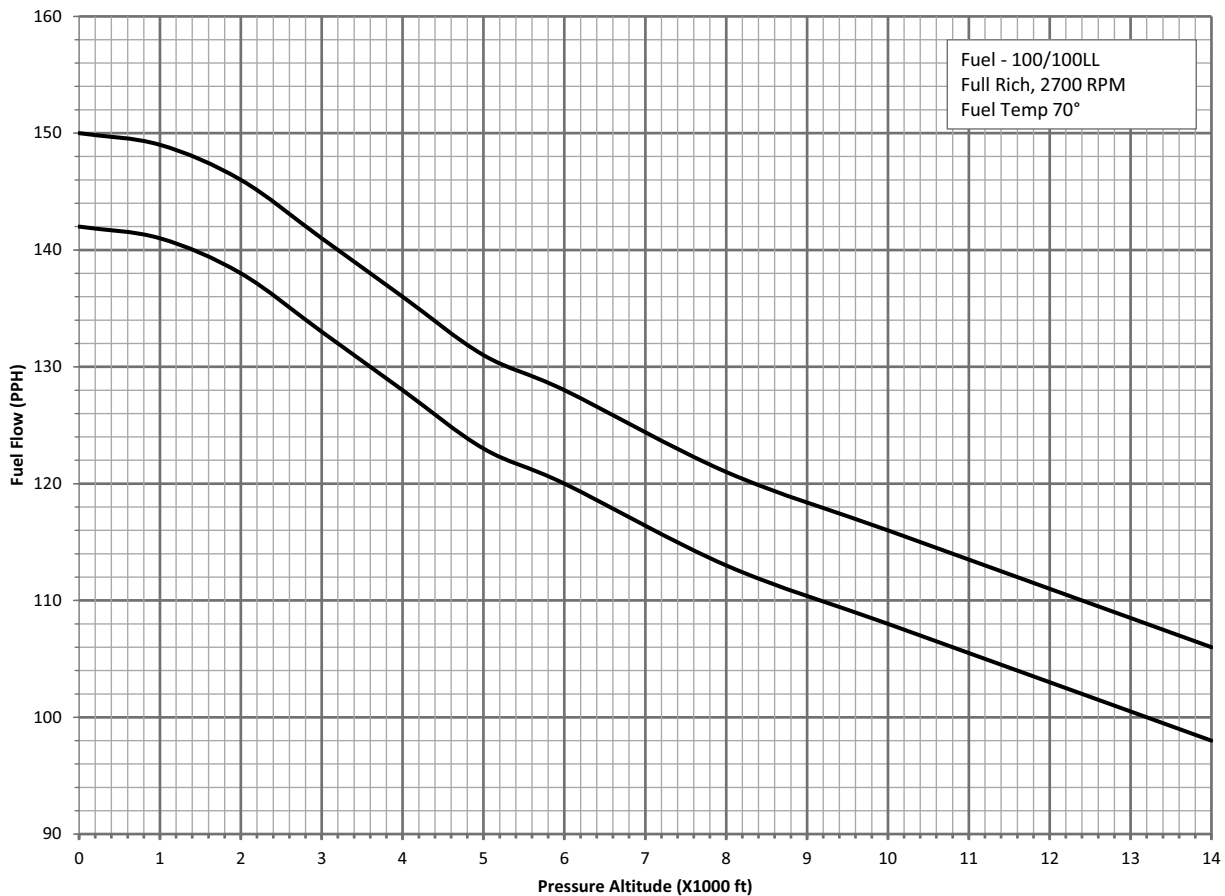

Figure 7-4. IO-550-A Altitude Leaning Schedule



**Table 7-7. IO-550-B Engine Altitude Leaning Schedule
Full Throttle RPM, Full Rich Mixture 300 BHP @ 2700 RPM**

Pressure Altitude (Set Altimeter at 29.92 in. Hg.)	Fuel Flow (lbs/hr)		Fuel Flow (gals/hr)		Metered Fuel Pressure PSID	
	Min.	Max.	Min.	Max.	Min.	Max.
Sea Level	146	156	24.9	26.6	17.2	18.3
1,000	145.5	155.5	24.8	26.5	17.1	18.2
2,000	145	155	24.7	26.4	17.0	18.1
3,000	144	154	24.5	26.3	16.9	17.9
4,000	142	152	24.2	25.9	16.5	17.5
5,000	139	149	23.7	25.4	16.1	17.0
6,000	135.5	145.5	23.1	24.8	15.5	16.5
8,000	127	137	21.6	23.3	14.2	15.1
10,000	117	127	19.9	21.6	12.8	13.6
12,000	110	120	18.7	20.4	11.9	12.6
14,000	105	115	17.9	19.6	11.3	11.9

Gasoline = 5.87 lbs per gallon @ 70° F.

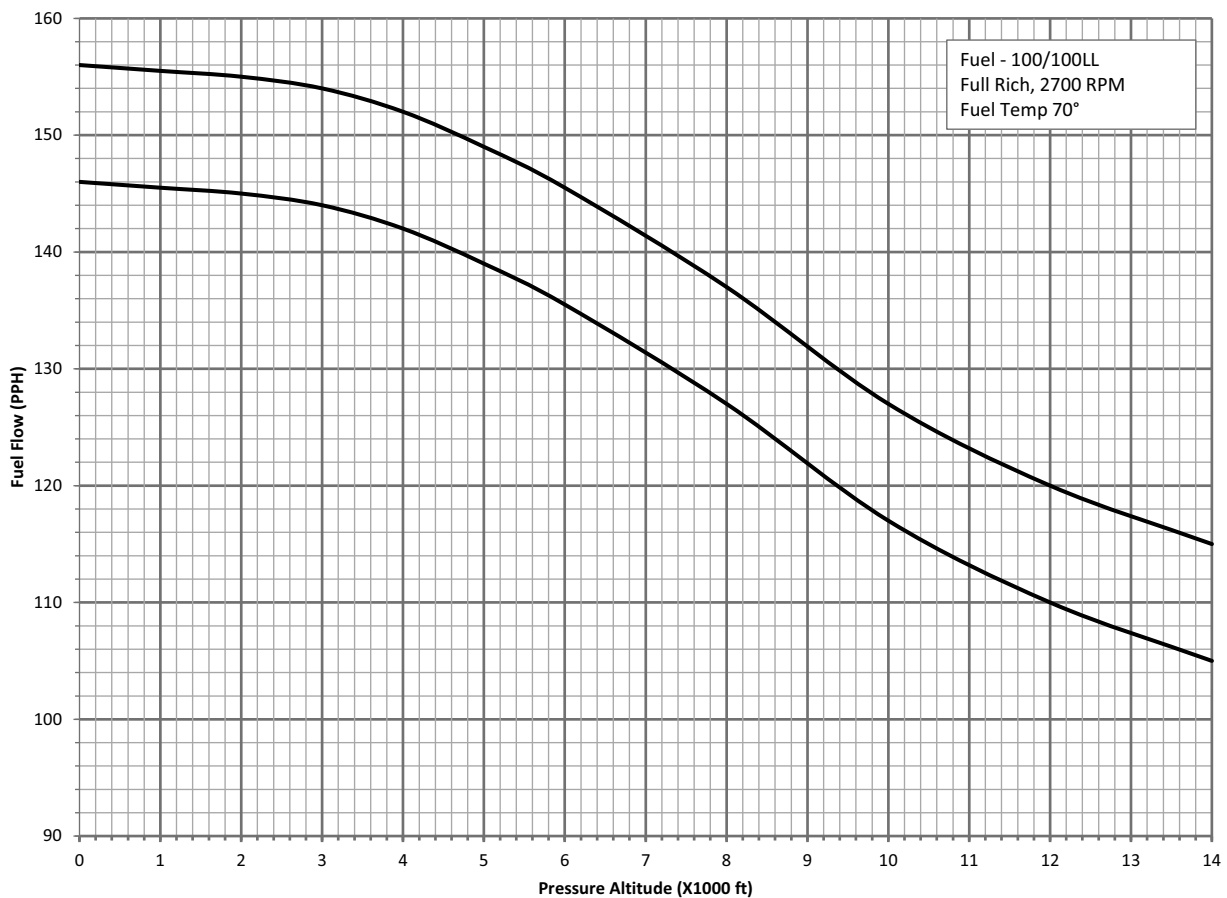

Figure 7-5. IO-550-B Altitude Leaning Schedule



Table 7-8. IO-550-C Engine Altitude Leaning Schedule
Full Throttle RPM, Full Rich Mixture 300 BHP @ 2700 RPM

Pressure Altitude (Set Altimeter at 29.92 in. Hg.)	Fuel Flow (lbs/hr)		Fuel Flow (gals/hr)		Metered Fuel Pressure PSID	
	Min.	Max.	Min.	Max.	Min.	Max.
Sea Level	152	160	25.9	27.2	18.2	18.9
1,000	151	159	25.7	27.1	18.0	18.7
2,000	148	156	25.2	26.6	17.5	18.2
3,000	143	151	24.4	25.7	16.7	17.4
4,000	138	146	23.5	24.9	15.9	16.5
5,000	134	142	22.8	24.2	15.3	15.9
6,000	130	138	22.1	23.5	14.7	15.3
8,000	123	131	21.0	22.3	13.6	14.1
10,000	118	126	20.1	21.5	12.9	13.4
12,000	113	121	19.3	20.6	12.3	12.7
14,000	108	116	18.4	19.8	11.7	12.1

Gasoline = 5.87 lbs per gallon @ 70° F.

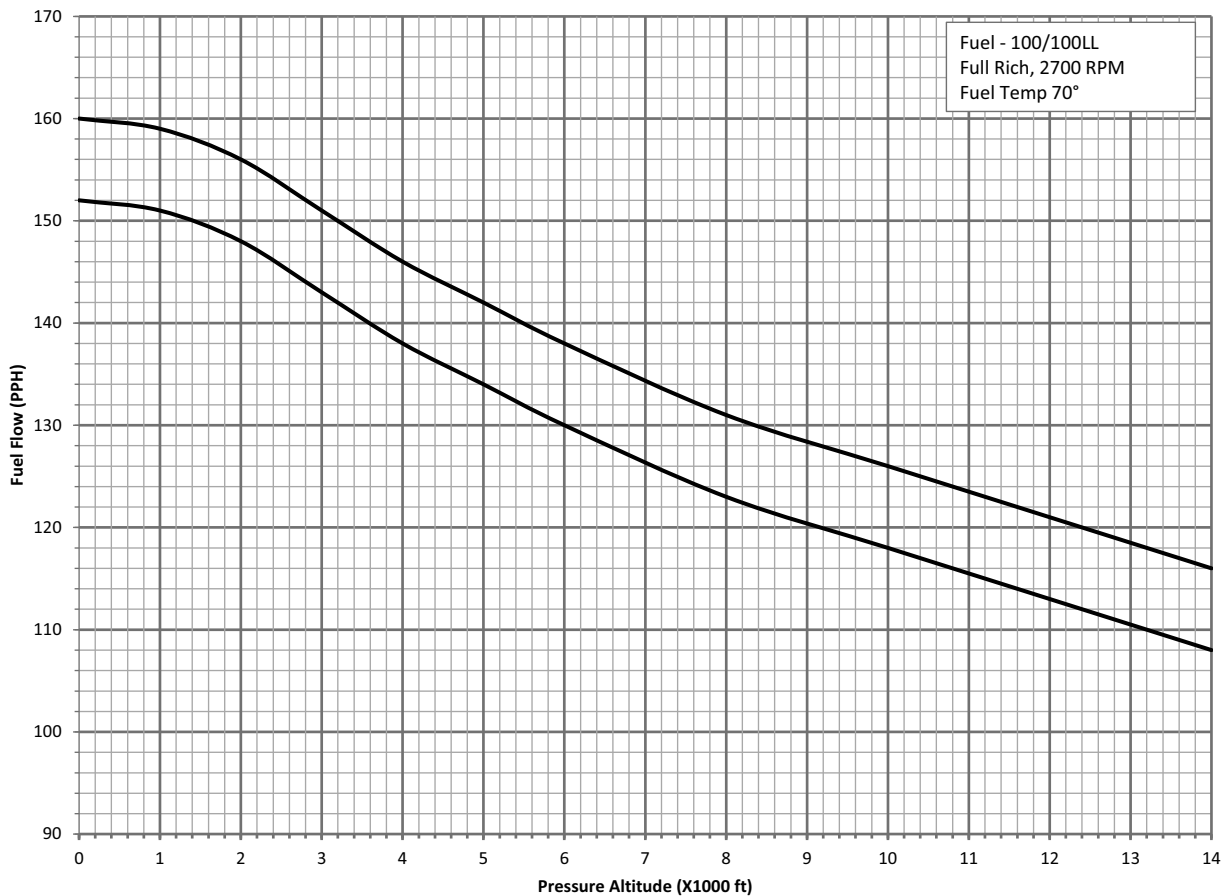

Figure 7-6. IO-550-C Altitude Leaning Schedule



**Table 7-9. IO-550-D, E, F, & L Engine Altitude Leaning Schedule
Full Throttle Static RPM, Full Rich Mixture 300 BHP @ 2700 RPM**

Pressure Altitude (Set Altimeter at 29.92 in. Hg.)	Fuel Flow (lbs/hr)		Fuel Flow (gals/hr)		Metered Fuel Pressure PSID	
	Min.	Max.	Min.	Max.	Min.	Max.
Sea Level	143	155	24.4	26.4	17.2	20.0
1,000	142.5	154.5	24.3	26.3	17.1	19.9
2,000	142	154	24.2	26.2	17.0	19.8
3,000	141	153	24.0	26.1	16.9	19.6
4,000	139	151	23.7	25.7	16.5	19.2
5,000	136	148	23.2	25.2	16.0	18.7
6,000	133	145	22.6	24.7	15.5	18.2
8,000	124	136	21.1	23.2	14.0	16.6
10,000	114	126	19.4	21.5	12.5	15.0
12,000	107	119	18.2	20.3	11.5	13.9
14,000	102	114	17.4	19.4	10.8	13.1

Gasoline = 5.87 lbs per gallon @ 70° F.

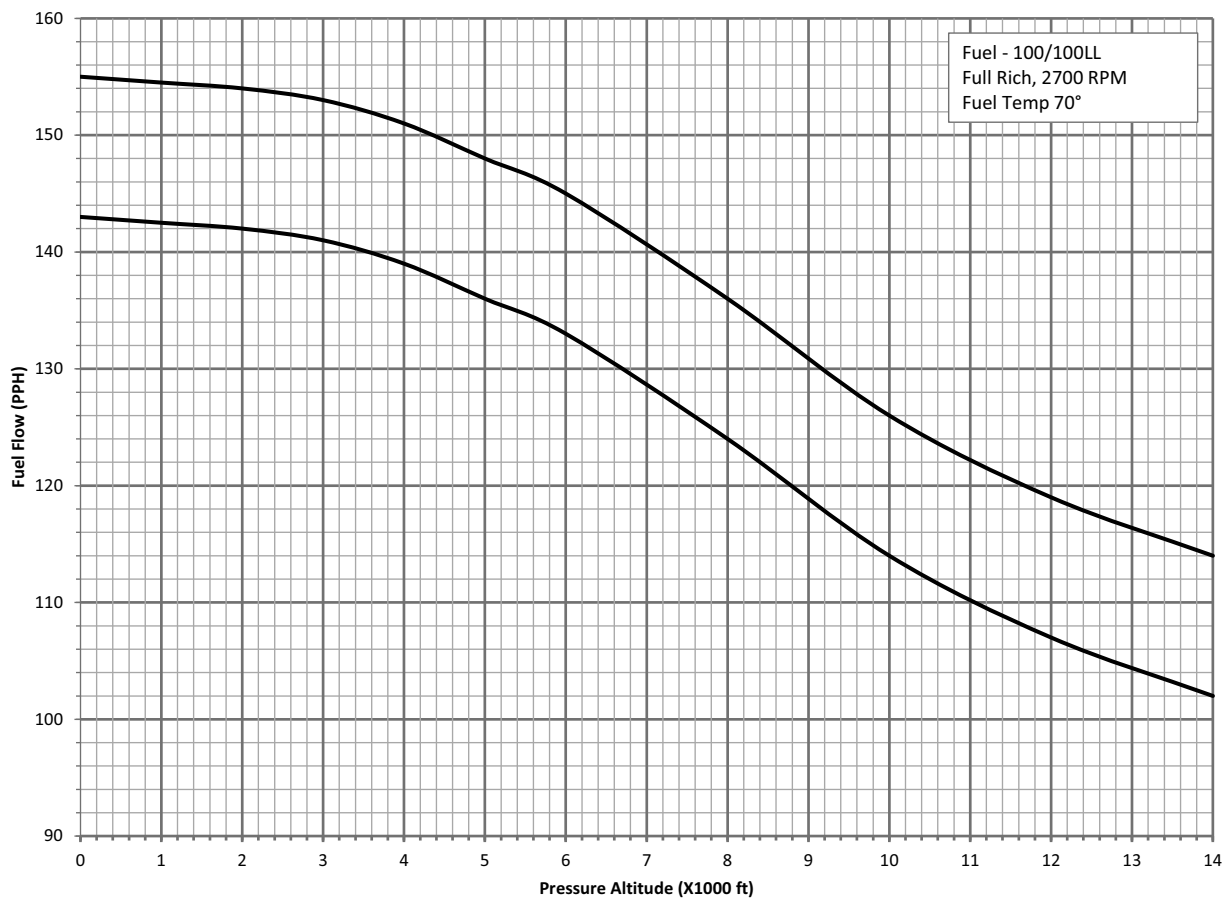

Figure 7-7. IO-55-D, E, F & L Altitude Leaning Schedule



7-3. Normal Operation

Information in this section supplements instructions for normal ground operation found in the AFM/POH. Adhere to the aircraft AFM/POH operating procedures.

WARNING

Before flying the aircraft, ensure all “Flight Prerequisites” in Section 7-2 have been completed, in addition to the aircraft manufacturer's instructions found in the AFM/POH.

Operation of a malfunctioning engine can result in additional damage to the engine, bodily injury or death.

Supplemental instructions for normal operation in this section are:

- Pre-operational Requirements
- Engine Start
- Engine Ground Run-up
- Engine Shutdown

7-3.1. Pre-operational Requirements

1. Check the oil level, and verify quantity is within specified limits.
2. Verify oil fill cap and dipstick are secure.
3. Drain all fuel sumps and strainers in accordance with aircraft manufacturer's recommendations.
4. Check the fuel system according to the Pilot's Operating Handbook (POH) and verify compliance with Section 7-2.2, “Engine Fuel Requirements.”
5. Check propeller and propeller hub for cracks, oil leaks, and security.
6. Check engine nacelle for signs of damage, leaks, and debris.
7. Check the throttle, mixture control, propeller (if equipped), carburetor heat (if equipped) and alternate air supply controls for freedom of movement and full range of travel.



7-3.2. Engine Start

WARNING

Do not attempt to start an engine with an over-primed or flooded induction system. Starting an engine with a flooded induction system can result in hydraulic lock and subsequent engine malfunction or failure. Allow excess fuel to drain from the intake manifold and/or cylinder prior to attempting to start the engine.

Refer to the aircraft POH for detailed engine starting procedures. Complete Section 7-3.1, “Pre-operational Requirements” prior to engine start. Be familiar with the quantity and location of the engine fuel system drains.

CAUTION: Attempting to start an engine with a partially discharged aircraft battery may result in damage to the starter relay or possible engine kick-back resulting in a broken starter adapter clutch spring and/or subsequent engine damage.

When starting the engine, ensure the battery is completely charged, especially in sub-freezing temperatures.

Verify the tasks listed in Table 7-2, “Flight Prerequisites,” have been completed in addition to those required by the aircraft POH, aircraft manufacturer, or Supplemental Type Certificate (STC) holder. Note the following:

- If the engine is being started in extreme cold, preheating may be required. Refer to Section 7-4.1, “Engine Operation in Extreme Cold.”
- If the engine is started in hot weather, refer to the AFM/POH
- If the engine is being started at high altitude, refer to the AFM/POH

WARNING

Ensure the propeller arc is clear of personnel and obstructions before starting the engine.

CAUTION: Release the starter as soon as the engine fires. Never engage the starter while the propeller is turning.

Engine operation without oil pressure will result in engine malfunction and probable failure.

NOTE: Check oil pressure frequently. Oil pressure indication must be noted within 30 seconds in normal weather. If no oil pressure is observed, stop the engine and investigate the cause.

1. Propeller Clear
2. Master Switch ON
3. Ignition Switch BOTH
4. Mixture Control FULL RICH
5. Propeller Control High RPM



Engine Operation

6. Boost Pump (if equipped) According to AFM/POH
7. Throttle..... ¼ Open
8. Primer (if equipped)..... ON (refer to AFM/POH
for priming time)

CAUTION: Release starter switch as soon as engine fires. Never engage the starter while the propeller is still turning.

EZR Do not energize the starter for longer than 30 seconds. If the engine does not start after cranking for 30 seconds, release the starter switch and allow the starter motor to cool for 3-5 minutes before another starting attempt.

SKY Do not engage the starter for longer than 10 seconds. Allow 20 seconds for the starter to cool after each engagement. If engine start is unsuccessful after six attempts, release the starter switch and allow the starter motor to cool for 30 minutes before another starting attempt is made.

9. Ignition Switch..... Start, then RELEASE
10. Throttle..... According to AFM/POH
11. Primer (if equipped)..... OFF (refer to AFM/POH
for priming time)
12. Oil Pressure..... Check
RESULT: Must have oil pressure indication within 30 seconds.

7-3.2.1. Cold Start

Follow the AFM/POH instructions, using the same procedure as for a normal start. After the engine begins running, it may be necessary to operate the boost pump intermittently to prevent the engine from stalling.

7-3.2.2. Flooded Engine

WARNING

Do not operate the engine if hydraulic lock is suspected. Engine damage may occur. Perform a “Hydraulic Lock Inspection” according to instructions in Section 6-5.2. If no fuel drainage is observed, discontinue starting attempts until the cause is determined. Inspect the cylinder drains for obstructions.

Excessive priming may cause fuel to accumulate in the induction system or cylinder faster than cylinder drains can evacuate it. If hydraulic lock is suspected, discontinue starting attempts until proper drain operation is verified.



7-3.2.3. Hot Start

For engines with CM continuous flow fuel injection systems, supplement the AFM/POH normal starting instructions with the following:

NOTE: For several minutes after stopping a hot engine, heat soaked fuel injection components, (especially the fuel pump) may cause fuel vaporization resulting in restarting difficulties. To reduce difficulty, perform the following steps:

1. Fuel Selector Valve ON
2. Throttle..... CLOSED

CAUTION: In the IDLE CUT-OFF position, the fuel manifold valve positively stops fuel flow to the fuel injectors if inlet fuel pressure is less than 1.0 psi. If the boost/prime pump is enabled with the mixture control in IDLE CUT-OFF and the pressure is above the fuel manifold valve nominal shutoff pressure, fuel will be forced past the fuel manifold valve, through the injectors and into the cylinders. Extended operation in this condition is not recommended. Excessive fuel in the cylinders' intake port will vent overboard through the cylinder drains and collect below the aircraft. Refer to AFM/POH for boost pump operational limits.

3. Mixture Control IDLE CUT-OFF
4. Boost Pump (if equipped) According to AFM/POH
5. Allow fuel to drain from induction/cylinder drains prior to engine start; follow AFM/POH starting instructions.



7-3.3. Ground Run-up

CAUTION: DO NOT operate the engine at run-up speeds unless the oil temperature in turbocharged engines is at least 100°F (38°C) (75°F (24°C) for naturally aspirated engines) and the oil pressure is within the 30-60 psi range. Refer to engine Maintenance and Overhaul manual for operating parameter exceptions where applicable. Operating the engine above idle before reaching minimum oil temperature may cause a loss of oil pressure and engine damage.

1. Maneuver aircraft nose into wind
2. Throttle..... IDLE

CAUTION: Avoid prolonged idle at low RPM to prevent spark plug fouling.

3. Propeller Control (if equipped)..... FULL INCREASE
4. Mixture..... FULL RICH
5. Throttle..... 900-1000 RPM
6. Maintain engine RPM between 900 and 1000 RPM for at least one minute or until engine oil temperature reaches minimum takeoff temperature (minimum takeoff temperature is 100°F (38°C) for turbocharged engines or 75°F (24°C) for naturally aspirated engines).

WARNING

Absence of RPM drop during the magneto check may be an indication of a faulty ignition circuit resulting in a condition known as “Hot Magneto.” Should the propeller be turned by hand, the engine may inadvertently start and cause personal injury or death. This condition must be corrected prior to continued aircraft operation.

CAUTION: When operating on single ignition, some RPM drop and slight engine roughness as each magneto is switched off should be noted. Excessive (greater than 150 RPM) RPM drop may indicate a faulty magneto or fouled spark plugs.

NOTE: If the engine runs roughly after single magneto operation, increase engine speed to 2200 RPM in the BOTH position and lean the mixture control until the RPM peaks for ten seconds before returning to the FULL RICH position to clear the spark plugs and smooth operation before returning to single magneto operation.

procedure continues on next page...



Limit ground operation to time necessary to complete engine warm-up and pre-flight checkout.

7. Throttle..... 1700 RPM

a. Magneto Checkout

1) Ignition Switch.....R

RESULT: RPM drops 150 RPM or less; record Left Magneto channel drop results. Maximum allowable RPM drop spread between magneto channels is 50 RPM.

2) Ignition Switch..... BOTH

RESULT: Engine RPM returns to approximately 1700 RPM. Allow ignition switch to remain in BOTH for approximately 30 seconds to clear engine.

3) Ignition Switch.....L

RESULT: RPM drops 150 RPM or less; record Right Magneto channel drop results. Maximum allowable RPM drop spread between magneto channels is 50 RPM.

b. Propeller Governor Checkout (if equipped)

1) Throttle..... According to AFM/POH

2) Propeller Control..... Low RPM position

RESULT: Engine RPM decreases to minimum governing speed or as specified by aircraft manufacturer.

3) Propeller Control..... High RPM position

4) Cycle the Propeller Governor control 2-3 times to cycle warm oil through the propeller hub.

If equipped:

5) Propeller Governor..... Feather

RESULT: RPM drops below minimum governing speed.

6) Propeller Governor..... Full Increase

RESULT: Engine RPM return to RPM before Propeller Feather check.



7-3.4. Engine Shutdown

Supplement the AFM/POH engine shutdown procedures with the following:

1. Boost Pump (if equipped) OFF
2. Throttle..... 1700 RPM

WARNING

Absence of RPM drop during the magneto check may be an indication of a faulty ignition circuit resulting in a condition known as “Hot Magneto.” Should the propeller be turned by hand, the engine may inadvertently start and cause personal injury or death. This condition must be corrected prior to continued aircraft operation.

CAUTION: When operating on single ignition, some RPM drop should be noted. Normal indications are up to 150 RPM drop and slight engine roughness as each magneto is switched off. RPM drop in excess of 150 RPM may indicate a faulty magneto or fouled spark plugs. Avoid prolonged single magneto operation to preclude spark plug fouling.

NOTE: If the engine runs roughly after single magneto operation, increase engine speed to 2200 RPM in the BOTH position and lean the mixture control until the RPM peaks for ten seconds before returning to the full rich position to clear the spark plugs and restore smooth operation before returning to single magneto operation.

3. Ignition Switch..... R
RESULT: RPM drops 150 RPM or less; record Left Magneto channel drop results. Maximum allowable RPM drop spread between magneto channels is 50 RPM.
4. Ignition Switch..... BOTH
RESULT: Engine RPM returns to approximately 1700 RPM.
5. Ignition Switch..... L
RESULT: RPM drops 150 RPM or less; record Right Magneto channel drop results. Maximum allowable RPM drop spread between magneto channels is 50 RPM.

CAUTION: Turbochargers require a cooling/spin down period before engine shutdown. Failure to allow the turbocharger to cool/spin down will shorten turbocharger service life. Supplement the AFM/POH aircraft shutdown procedures with these instructions:

6. Throttle.....IDLE
RESULT: For turbocharged engines only, allow engine to run for five minutes below 900 RPM to allow turbochargers to slow to a lower RPM and cool down. For all other, proceed to next step.
7. Mixture Control IDLE CUT-OFF
8. Ignition Switch..... OFF
9. Fuel Selector OFF (according to AFM/POH)



7-4. Engine Operation in Abnormal Environments

The anticipated types of abnormal environments are:

- Extreme cold weather (Reference AFM/POH and Section 7-4.1)
- Extreme hot weather (Reference AFM/POH)
- High density altitude ground operation (Reference AFM/POH)

7-4.1. Engine Operation in Extreme Cold

Engine starting is more difficult in extremely cold weather. Cold soaking causes the oil to thicken (more viscous) and clearances are reduced due to the lower temperature. These factors increase engine friction, reduce engine cranking rpm and increase the starter cranking amperage from the battery. At low temperatures, aviation gasoline does not vaporize readily, further complicating the starting procedure.

WARNING

Over priming can cause a flooded intake resulting in a “hydraulic lock” event and subsequent engine malfunction or failure. If you over-prime (flood) the engine, ensure excess fuel has drained from the intake manifold and/or cylinder prior to attempting engine start.

CAUTION: Use an external power source when attempting to start aircraft engine in cold weather. Attempting to start an engine with a partially discharged aircraft battery may result in damage to the starter relay or possible engine kick-back resulting in a broken starter adapter clutch spring and/or subsequent engine damage.

False starting (failure to continue running after starting) often results in condensation on spark plug electrodes. This moisture can freeze and must be eliminated either by preheating the engine or removing and cleaning the spark plugs.

Engine preheating and an auxiliary power unit (APU) are required to facilitate engine starting when the engine has been exposed to temperatures below 20°F (-7°C) for more than two hours. Refer to Section 7-4.1.1 and the AFM/POH for specific instructions. At ambient temperatures between 20° and 40°F (-7° and 4°C), refer to Section 7-4.1.1.3.

WARNING

Failure to properly preheat a cold-soaked engine may result in oil congealing within the engine, oil hoses, and oil cooler with subsequent loss of oil flow, possible damage to the engine, and subsequent engine failure.

Superficial application of preheat to a cold soaked engine can cause damage to the engine. An inadequate application of preheat may warm the engine enough to permit starting but will not decongeal oil in the sump, lines, cooler, filter, etc. Congealed oil in these areas require considerable preheat. The engine may start and appear to run satisfactorily, but can be damaged from lack of lubrication due to the congealed oil



clogging engine oil passages. The amount of damage will vary and may not become evident for many hours. However, the engine may be severely damaged and may fail shortly after application of high power.

Prior to operation and/or storage in cold weather, ensure the engine is serviced with the correct viscosity oil for the ambient air temperature.

In the event of temporary cold weather operation, store the aircraft in a heated hangar between flights. Service the oil sump as required with the specified oil grade according to the “Engine Oil Servicing” instructions in Section 6-4.8.

7-4.1.1. Engine Preheating

CAUTION: Proper engine preheating procedures require thorough application of preheat to all parts of the engine. Apply hot air directly to the oil sump and external oil lines as well as the cylinders, air intake, and oil cooler. Excessively hot air can damage non-metallic components such as seals, hoses, and drive belts; do not attempt to hasten the preheat process.

The preferred method of preheating is to place the aircraft in a heated hangar for a minimum of four hours prior to flight. Optional preheating methods are:

- A high volume combustion heater with ducts directed to the engine oil sump, cylinders, and oil cooler; refer to Section 7-4.1.1.1.

OR

- An engine mounted preheating system; refer to Section 7-4.1.1.2.

7-4.1.1.1. Engine Preheat with a Combustion Heater

If a heated hangar is not available and the aircraft and engine have been exposed to temperatures below 20°F (-7°C) for two hours or more, without an engine mounted preheating system, use the following method:

1. Select a high-volume air heater.

NOTE: Small electric heaters inserted in the cowling opening do not appreciably warm the oil and may result in superficial preheating.

2. Preheat all engine parts. Apply preheated air directly to the listed parts for at least 30 minutes:
 - a. Oil sump
 - b. Oil filter
 - c. External oil lines
 - d. Oil cooler
 - e. Cylinder assemblies
 - f. Air intake



3. Periodically feel the top of the engine for warmth. Apply heat directly to the induction tubes and cylinders will promote vaporization and ease starting. Alternately heat the sump and engine cylinders until engine start.
4. Start the engine immediately after completion of the preheating process. Since the engine will be warm, follow the normal start instructions in Section 7-3.2.

CAUTION: If oil pressure is not indicated within 30 seconds, shut down the engine and determine the cause. Operating the engine without oil pressure may result in engine damage. Do not close the cowl flaps in an attempt to hasten engine warm-up.

5. Operate the engine at 1000 RPM until some oil temperature is indicated.
 - a. Monitor the oil pressure closely. If necessary, retard the throttle to maintain oil pressure below 100 psi. If oil pressure is less than 30 psi, or cannot be maintained below 100 psi, shut the engine down and repeat the preheat process. Do not close the cowl flaps to facilitate engine warm-up.
 - b. Monitor the oil temperature until it reaches minimum takeoff oil temperature (minimum takeoff temperature is 100°F (38°C) for turbocharged engines or 75°F (24°C) for naturally aspirated engines).

CAUTION: Do not operate the engine at speeds above 1700 RPM unless the oil temperature reaches minimum takeoff oil temperature and indicated oil pressure is between 30 and 60 psi. Refer to engine Maintenance and Overhaul manual for operating parameter exceptions where applicable

6. Run the engine up to 1700 RPM; in 100 RPM increments to prevent oil pressure from exceeding 100 psi.

WARNING

Operating the engine above 1700 RPM before reaching the minimum oil temperature may result in engine malfunction, engine failure, injury or death.

7. At 1700 RPM, adjust the propeller control to LOW RPM (if equipped) until minimum governing RPM is observed; return the control to HIGH RPM. Repeat this procedure three or four times to circulate warm oil into the propeller dome.
8. If the aircraft manufacturer recommends checking the propeller feathering system, move the control to the FEATHER position. Do not allow the RPM to drop more than 300 RPM below minimum governing speed.

CAUTION: Continually monitor oil pressure during run up.

9. When oil temperature has reached minimum takeoff oil temperature and oil pressure does not exceed 60 psi at 2500 RPM, the engine has been warmed sufficiently to accept full rated power.



7-4.1.1.2. Engine Preheat with an Engine-Mounted Preheater

WARNING

Do not leave an engine-mounted pre-heater system on for more than 24 hours prior to flight. Continuous operation of engine-mounted preheater systems may result in aggressive internal engine corrosion.

If a heated hangar is not available and the aircraft and engine have been exposed to temperatures below 20°F (-7°C) for two hours or more and has an engine-mounted preheating system the following procedure may be used.

Engine mounted preheating systems should include individual cylinder head heater thermocouples, oil sump heater pad and crankcase heater pad. The use of a nacelle blanket will increase the effectiveness of engine preheating.

1. Follow the preheating system's manufacturer's installation and operation instructions.
2. Begin preheating of the engine at least five hours prior to expected departure. Do not operate an engine preheating system continuously for more than 24 hours.

NOTE: The use of an approved thermal blanket or cover will help reduce the effects of wind and cold air circulation when the aircraft is not stored in a hangar. The preheating system manufacturer should have thermal blankets available.

3. Start the engine immediately after completion of the preheating process using the normal start procedure in Section 7-3.2.

CAUTION: If oil pressure is not indicated within 30 seconds, shut down the engine and determine the cause. Operating the engine without oil pressure may result in engine damage. Do not close the cowl flaps in an attempt to hasten engine warm-up.

4. Operate the engine at 1000 RPM until some oil temperature is indicated.
 - a. Monitor the oil pressure closely. If necessary, retard the throttle to maintain oil pressure below 100 psi. If oil pressure is less than 30 psi, or cannot be maintained below 100 psi, shut the engine down and repeat the preheat process. Do not close the cowl flaps to facilitate engine warm-up.
 - b. Monitor the oil temperature until it reaches at minimum takeoff oil temperature (minimum takeoff temperature is 100°F (38°C) for turbocharged engines or 75°F (24°C) for naturally aspirated engines).

CAUTION: Do not operate the engine at speeds above 1700 RPM unless the oil temperature reaches minimum takeoff oil temperature and the oil pressure is between 30 to 60 psi.

5. Run the engine up to 1700 RPM; approach this RPM in increments to prevent oil pressure from exceeding 100 psi.



WARNING

Operating the engine above 1700 RPM before reaching the minimum takeoff oil temperature may result in engine malfunction, engine failure, injury or death.

6. At 1700 RPM, adjust the propeller control (if equipped) to LOW RPM until minimum governing RPM is observed; return the control to HIGH RPM. Repeat this procedure three or four times to circulate warm oil into the propeller dome.
7. If the aircraft manufacturer recommends checking the propeller feathering system, move the control to the FEATHER position but do not allow the RPM to drop more than 300 RPM below minimum governing speed.

CAUTION: Continually monitor oil pressure during run up.

8. When oil temperature has reached minimum takeoff oil temperature and oil pressure does not exceed 60 psi at 2500 RPM, the engine has been warmed sufficiently to accept full rated power.

7-4.1.1.3. Cold Weather Starting Without Preheating

At ambient temperature between 20° to 40°F (-7° to 4°C), perform the following:

CAUTION: Attempting to start your engine with a partially discharged aircraft battery may result in damage to the starter relay or possible engine kickback, resulting in a broken starter adapter clutch spring and/or subsequent internal engine damage.

1. Use an external power source or ensure the aircraft battery is fully charged.
2. Use the normal start procedure in Section 7-3.2 and the aircraft AFM/POH. Do not overprime the engine.

WARNING

Overpriming can cause a flooded intake resulting in a “hydraulic lock” event and subsequent engine malfunction or failure. If you over prime, or flood your engine, ensure excess fuel has drained from the intake manifold and/or cylinder prior to attempting engine starting.

CAUTION: If oil pressure is not indicated within 30 seconds, shut down the engine and determine the cause. Operating the engine without oil pressure may result in engine damage. Do not close the cowl flaps in an attempt to hasten engine warm-up.

3. Operate the engine at 1000 RPM until some oil temperature is indicated.
4. Monitor the oil pressure closely. If necessary, retard the throttle to maintain oil pressure below 100 psi. If oil pressure is less than 30 psi, or cannot be maintained below 100 psi, shut the engine down and follow the preheat instructions to prevent engine damage.



Engine Operation

5. Monitor the oil temperature until it reaches at minimum takeoff oil temperature (minimum takeoff temperature is 100°F (38°C) for turbocharged engines or 75°F (24°C) for naturally aspirated engines).

CAUTION: In the next step, do not operate the engine at speeds above 1700 RPM unless the oil temperature reaches minimum rated takeoff temperature and the oil pressure is between 30 to 60 psig. Refer to engine Maintenance and Overhaul manual for operating parameter exceptions where applicable.

6. Run the engine up to 1700 RPM; approach this RPM in increments to prevent oil pressure from exceeding 100 psi.

WARNING

Operating the engine above 1700 RPM before reaching the minimum oil temperature may result in engine malfunction, engine failure, injury or death.

7. At 1700 RPM, adjust the propeller control (if equipped) to LOW RPM until minimum governing RPM is observed; return the control to HIGH RPM. Repeat this procedure three or four times to circulate warm oil into the propeller dome.
8. If the aircraft manufacturer recommends checking the propeller feathering system, move the control to the FEATHER position but do not allow the RPM to drop more than 300 RPM below minimum governing speed.

CAUTION: Continually monitor oil pressure during run up.

9. When oil temperature has reached minimum takeoff oil temperature and oil pressure does not exceed 60 psi at 2500 RPM, the engine has been warmed sufficiently to accept full rated power.



Chapter 8. Troubleshooting

Fault isolation paths within this chapter indicate the most likely causes of given symptom(s) and corrective action(s). The fault isolation paths and repair procedures are developed from log book entries and best known practices. New symptoms, fault isolation methods, and corrective actions may be added in the future, when warranted.

NOTE: Fault isolation paths provided are for Continental Motors engines equipped with a carburetor or continuous flow fuel injection system. For engines equipped with FADEC or servo controlled fuel injection systems, refer to the primary ICA (**Ref: Section 1-1.1**).

WARNING

Any attempt by unqualified personnel to adjust, repair, or replace any parts may result in engine malfunction or failure. Continued operation of a malfunctioning engine can cause further damage to a disabled component and possible injury to personnel. Do not return an engine to service unless it functions according to specifications.



8-1. General Troubleshooting

Troubleshooting procedures vary for engines with carburetors versus fuel injected engines. Refer to Section 8-1.2 for fuel injected engines and Section 8-1.1 for engine with carburetors.

8-1.1. General Troubleshooting for Engines equipped with a Carburetor

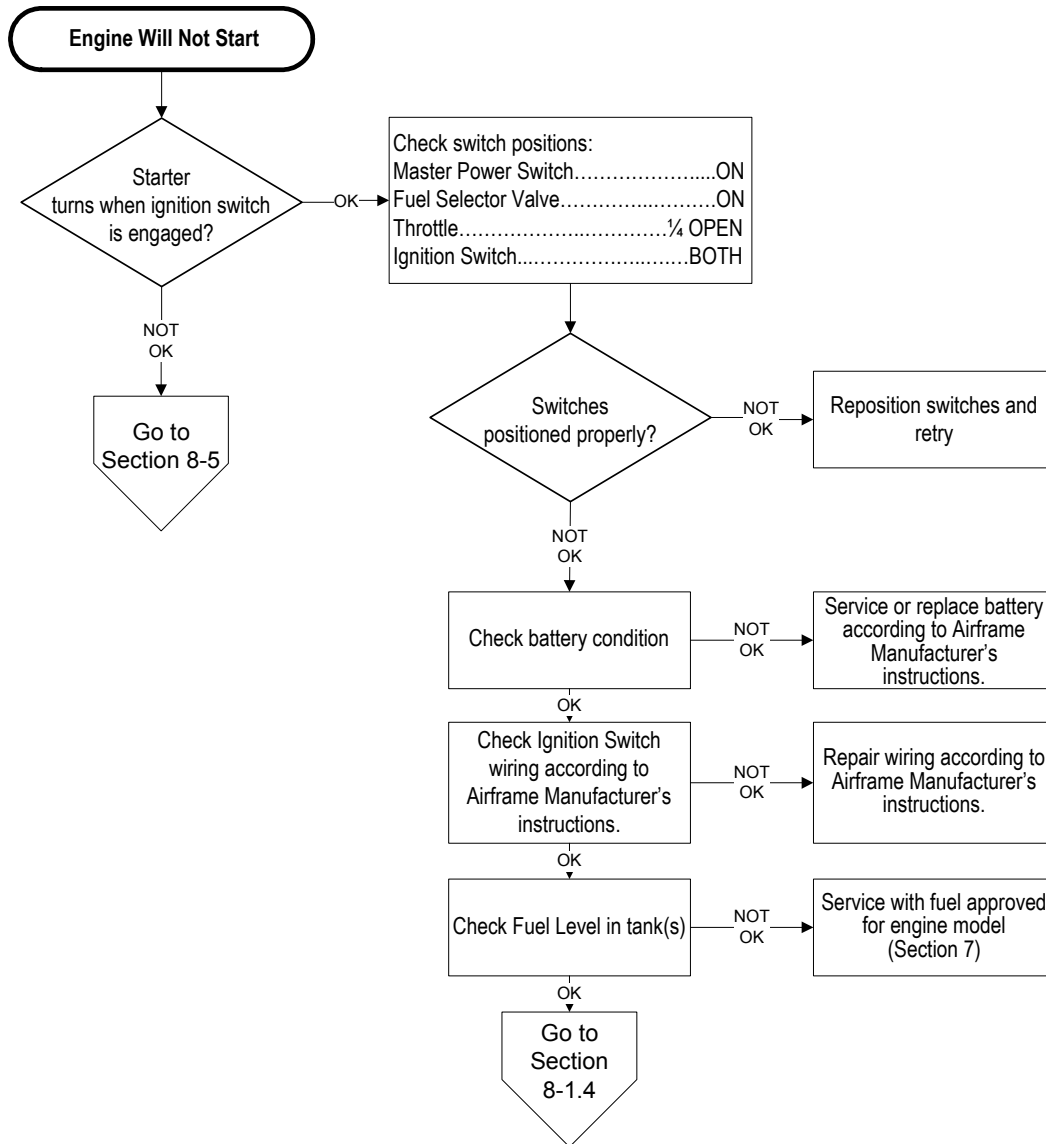



8-1.2. General Troubleshooting for Engines with CM Continuous Flow Fuel Injection Systems

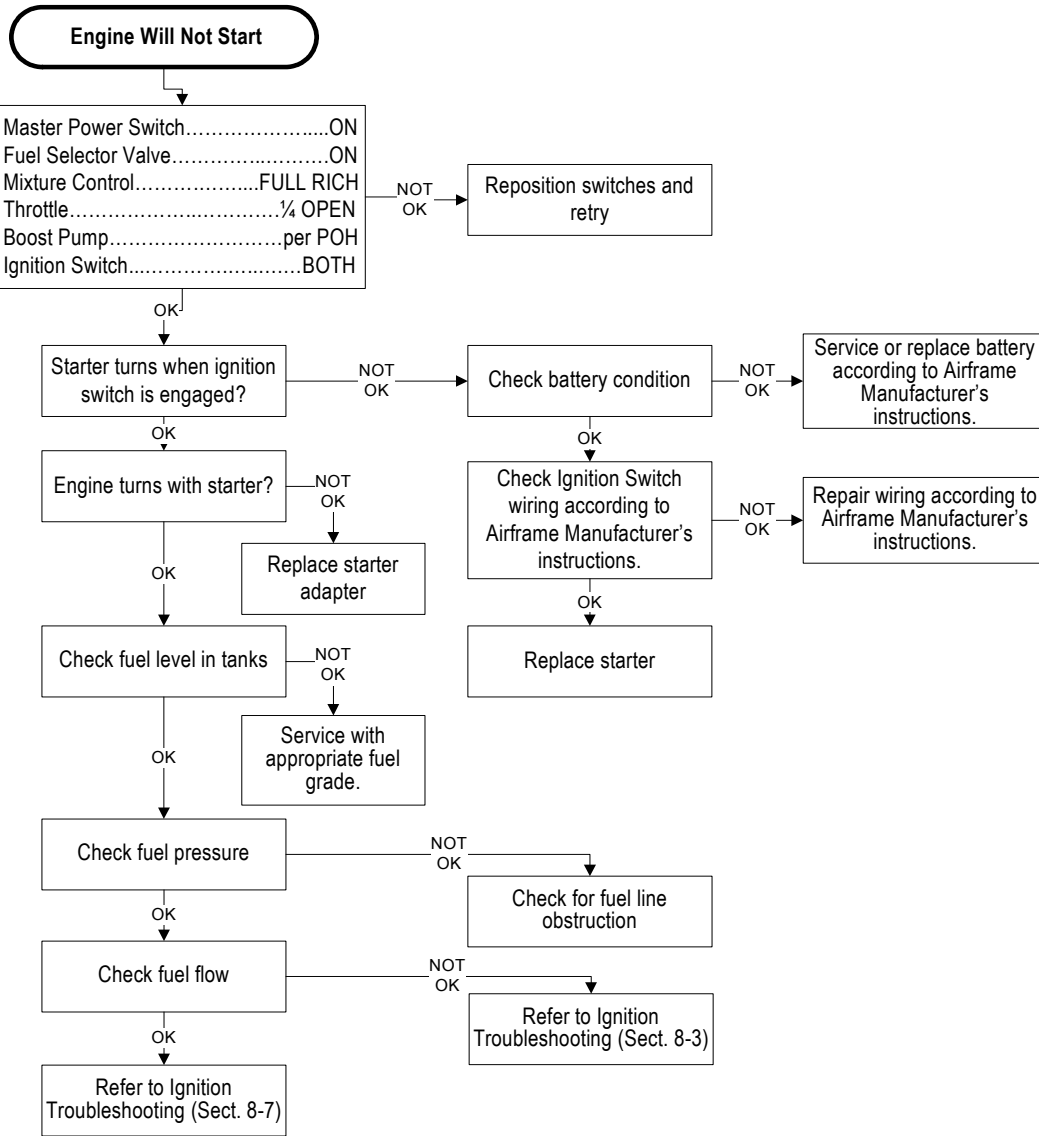



8-1.3. Engine Runs Rough

Engine troubleshooting techniques vary depending on the engine fuel system. For engines equipped with a carburetor refer to Section 8-1.3.1. To troubleshoot rough running engines equipped with continuous flow fuel injection systems, refer to Section 8-1.3.1.

8-1.3.1. Engine Runs Rough (equipped with Carburetor)

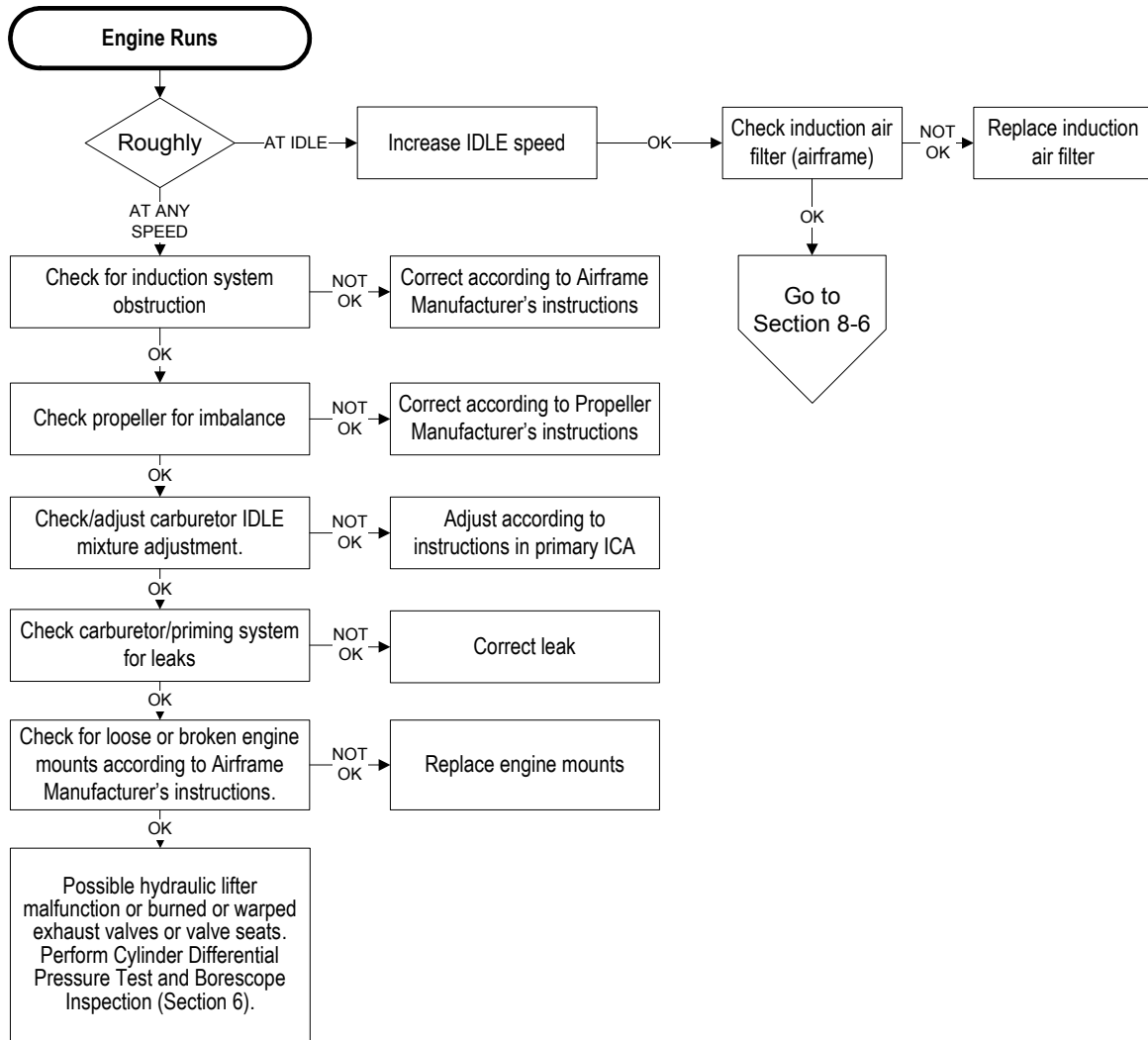



8-1.3.2. Engine Runs Rough (equipped with CM Continuous Flow Fuel Injection System)

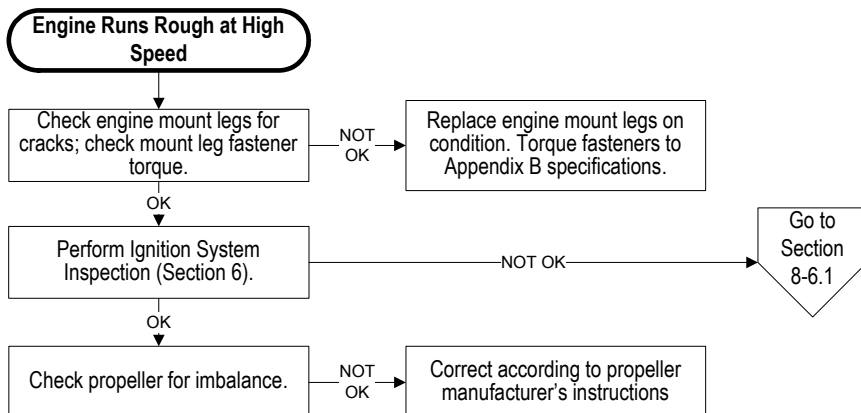
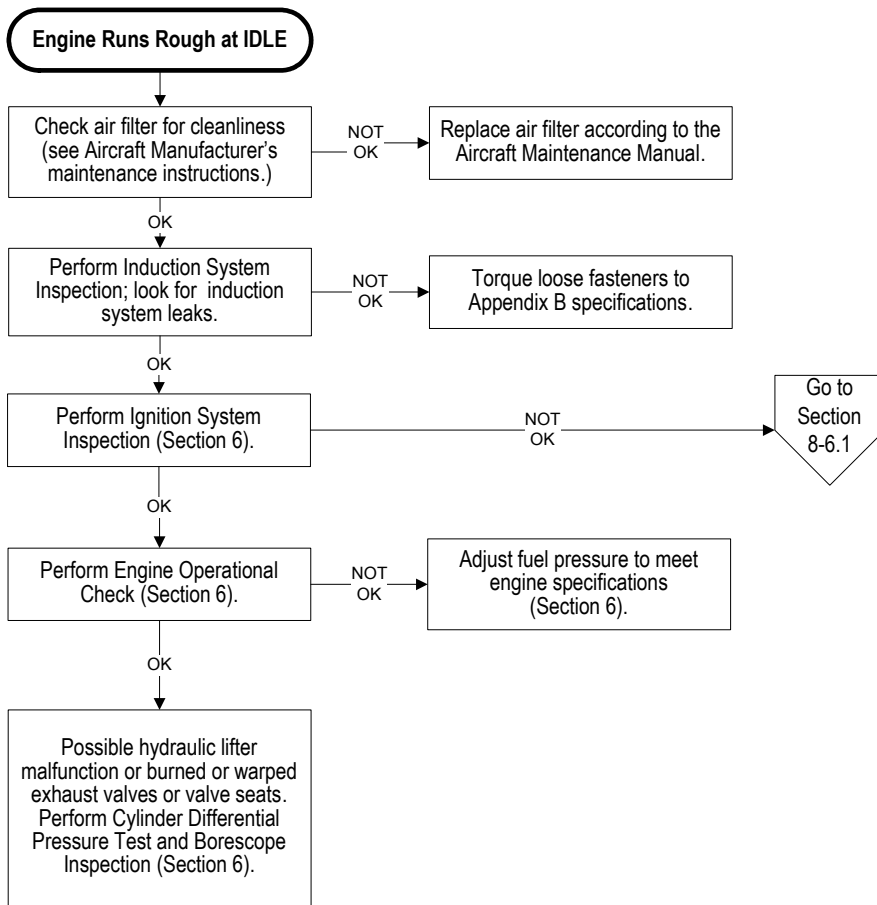



8-1.4. Engine Will Not Run

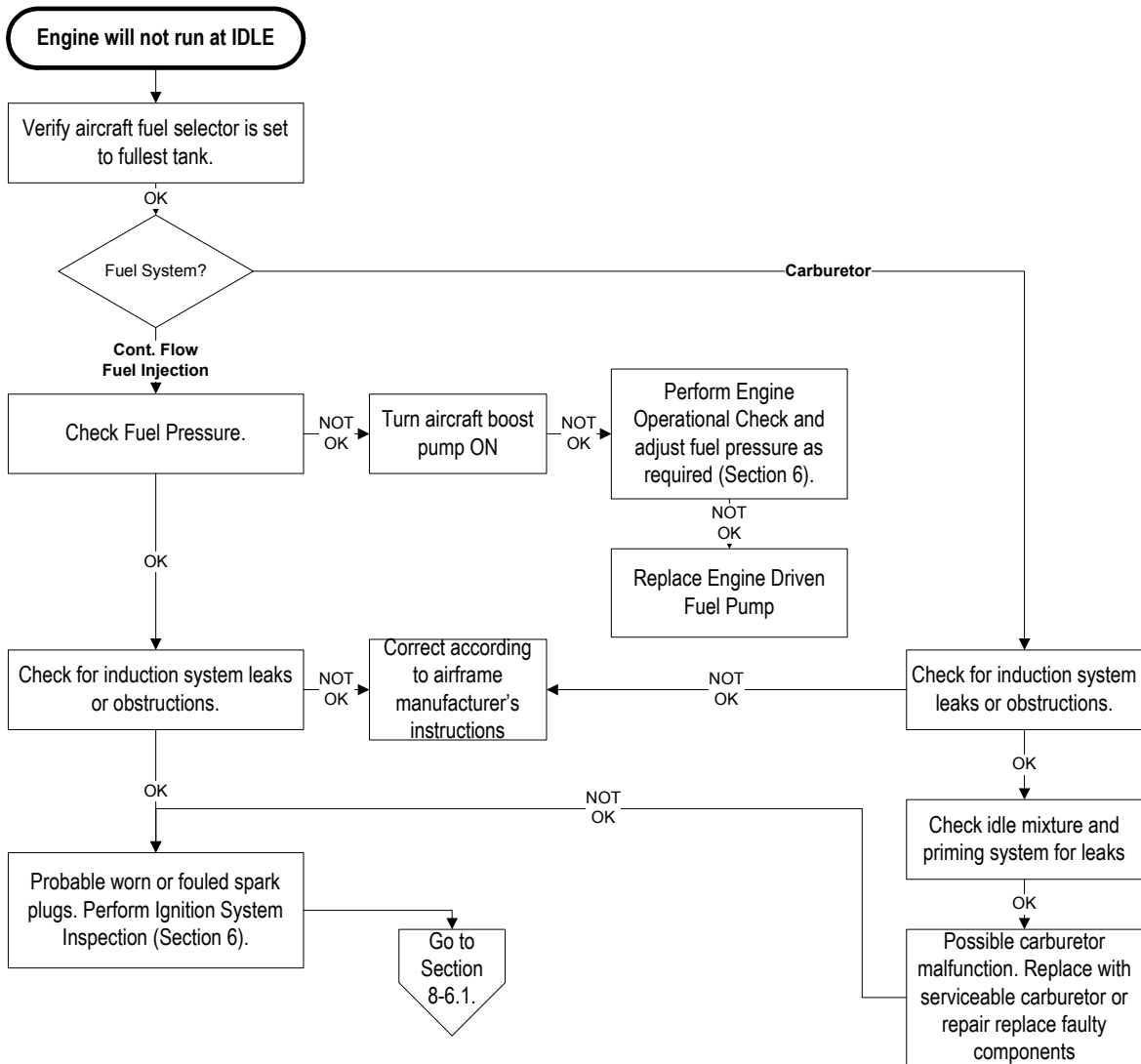

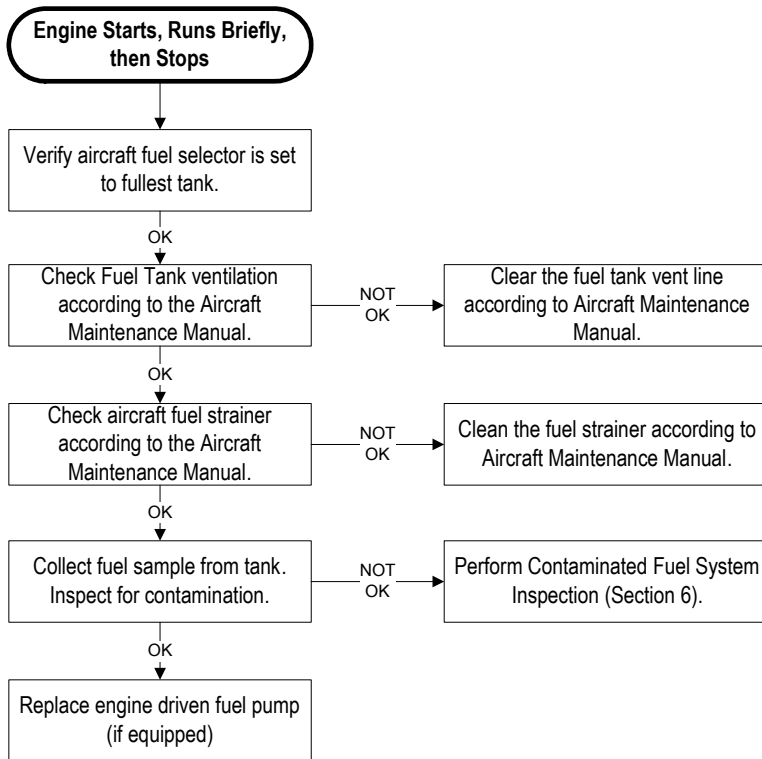

8-1.5. Engine Indication Malfunctions

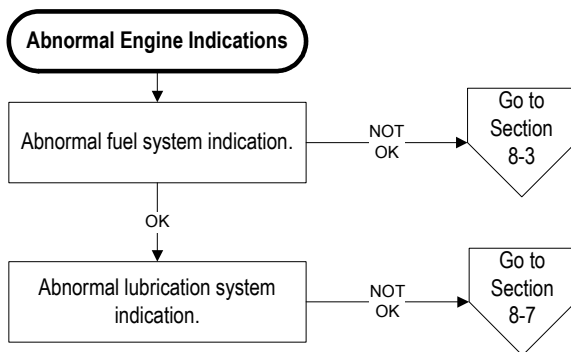



8-1.6. Engine Performance Malfunctions

- Engine Runs Rich at Cruise Powersee Section 8-3
- Engine Acceleration Poor see Poor Engine Performance
- Engine Misses at High Speedsee Section 8-8

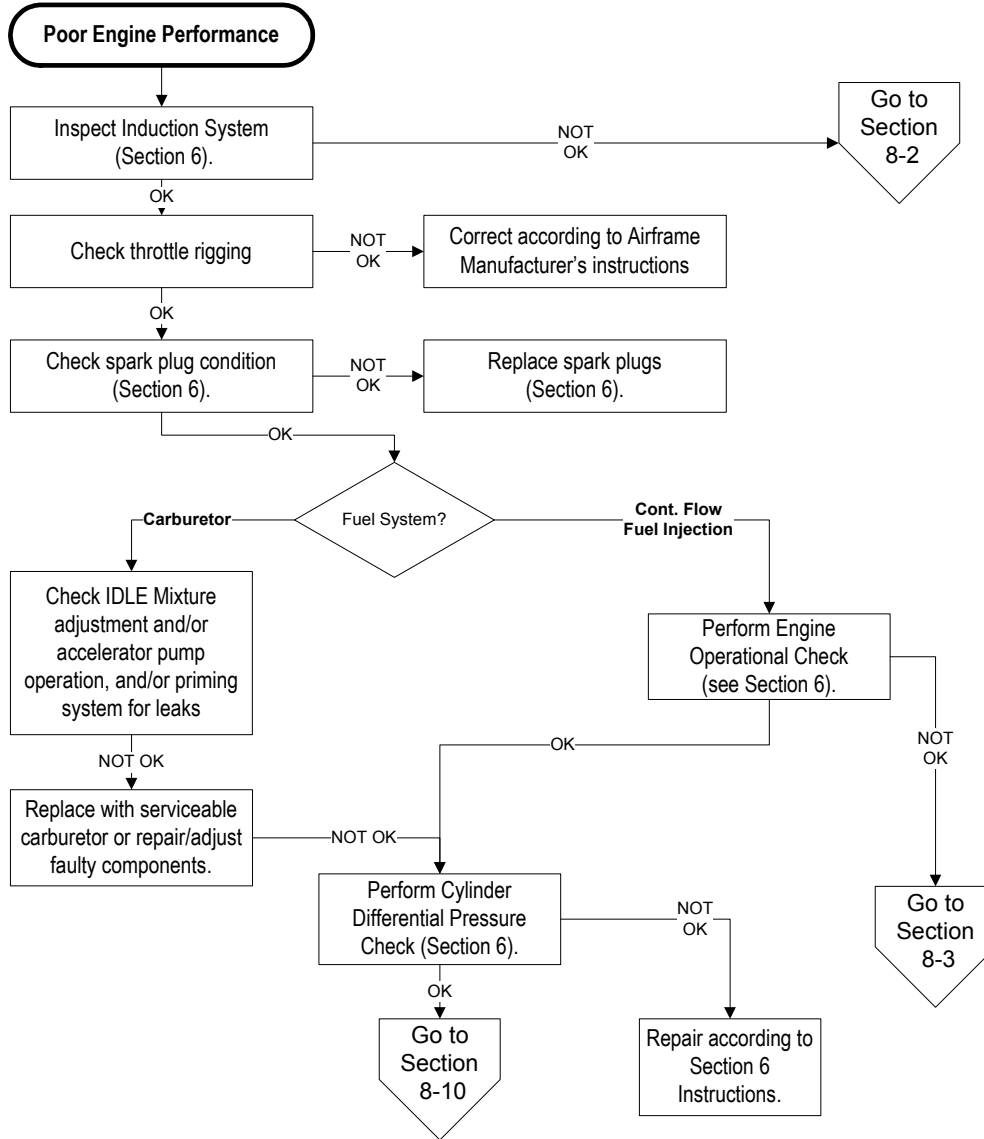

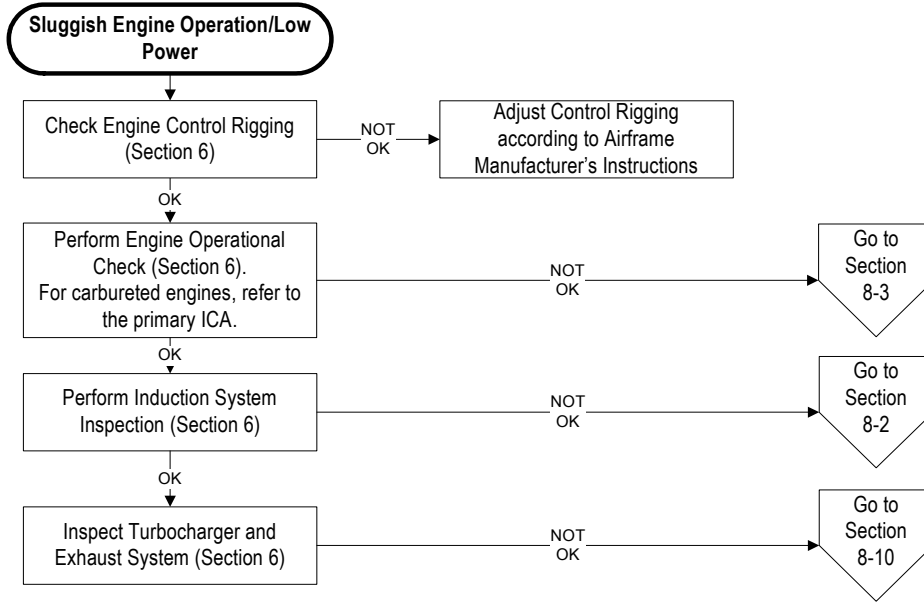

8-2. Induction System

- Engine Will Not Start..... see Section 8-2.1
- Engine Will Not Run..... see Section 8-2.2
- Engine Lacks Power/Low Manifold Air Pressure see Section 8-2.3
- Low Manifold Air Pressure/Loss of Aircraft Critical Altitude see Section 8-2.4

8-2.1. Engine Will Not Start

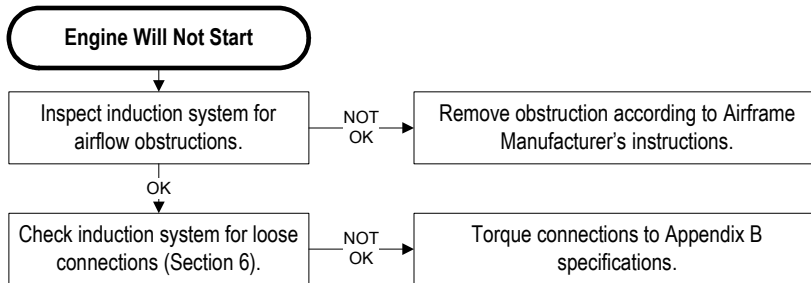



8-2.2. Engine Will Not Run

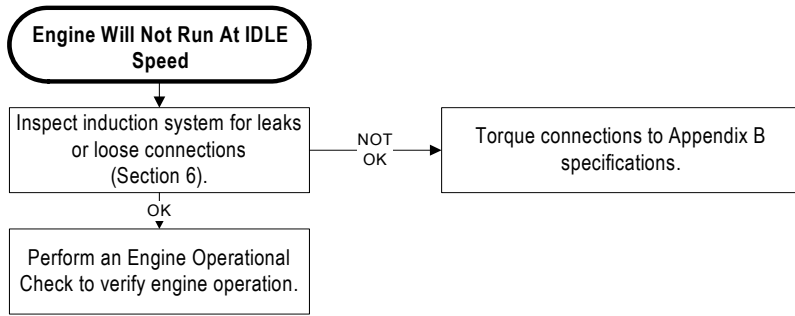

8-2.3. Engine Lacks Power/Manifold Pressure Low (Naturally Aspirated Models)

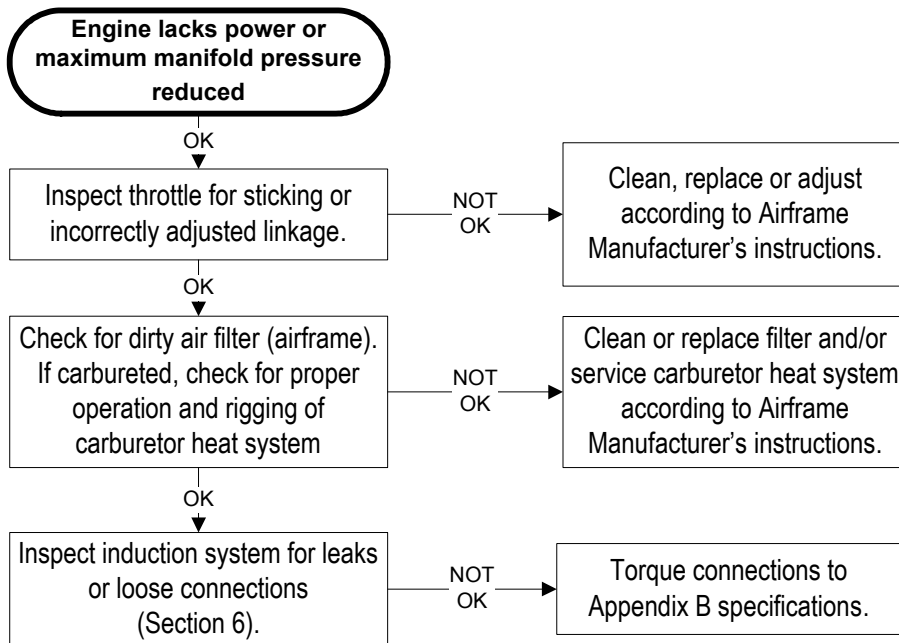



8-2.4. Engine Lacks Power/Manifold Pressure Low (Turbocharged Models)

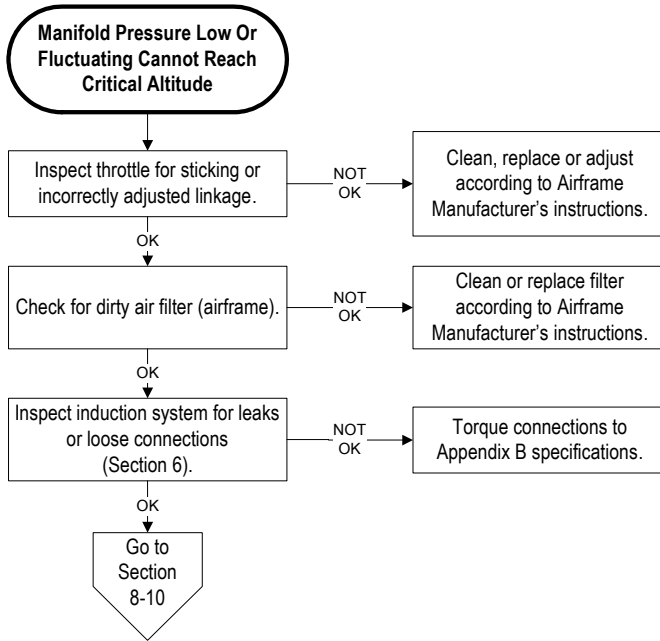



8-3. CM Continuous Flow Fuel Injection System

- Engine Will Not Start.....see Section 8-2.1
- Fluctuating or Erroneous Fuel Flow.....see Section 8-3.2
- Poor Accelerationsee Section 8-3.3
- Fuel Injector Operational Checksee Section 8-3.4

8-3.1. Engine Will Not Start

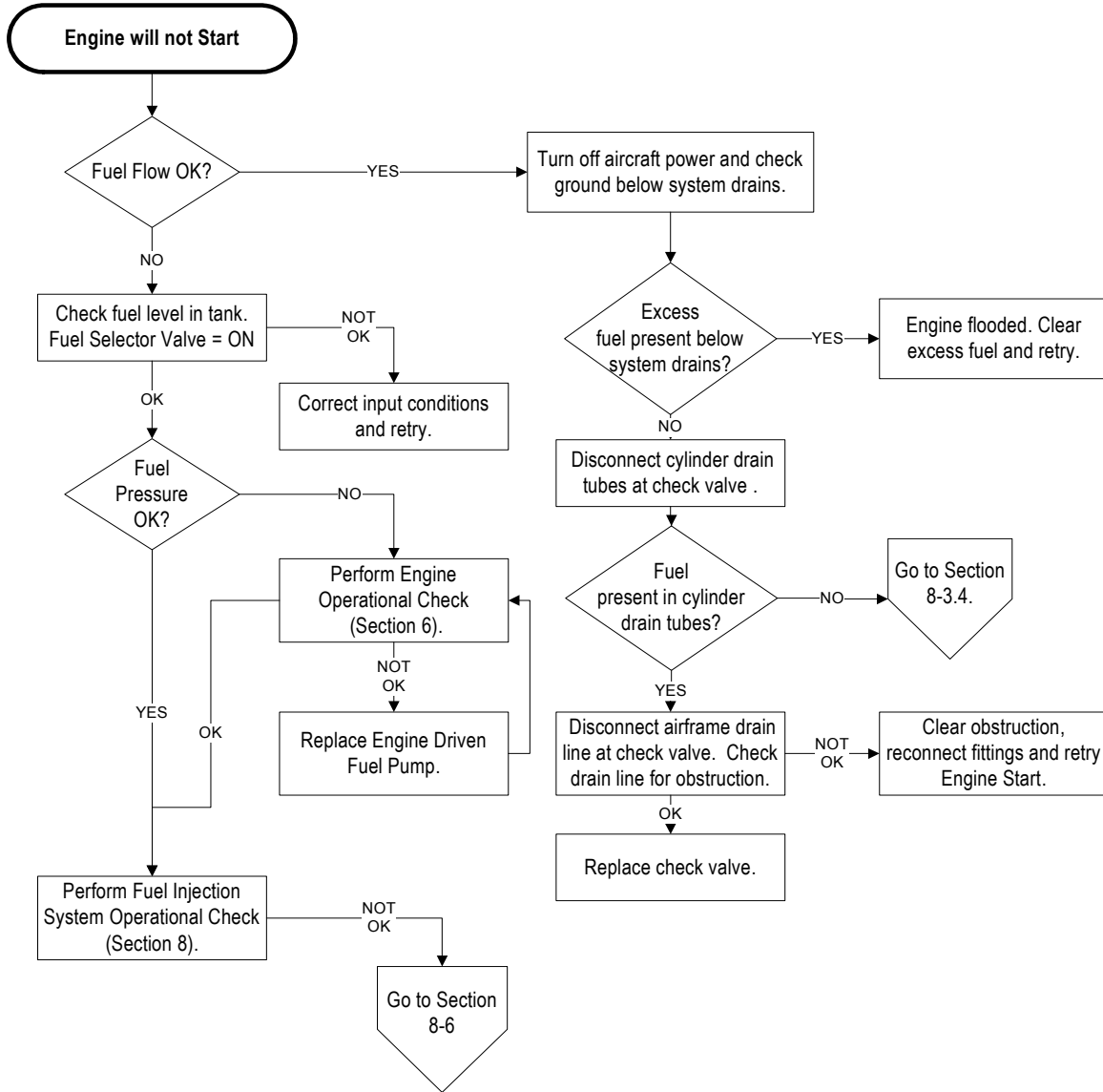



8-3.2. Fluctuating or Erroneous Fuel Flow

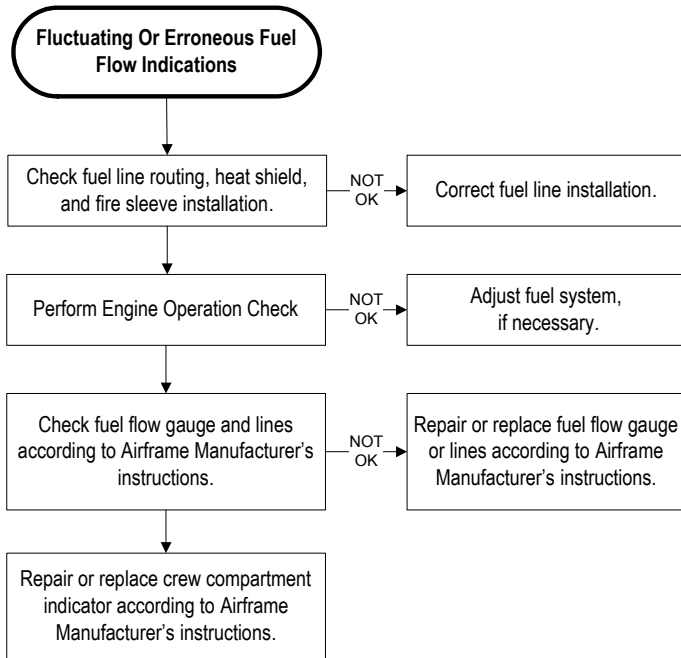

8-3.3. Poor Acceleration

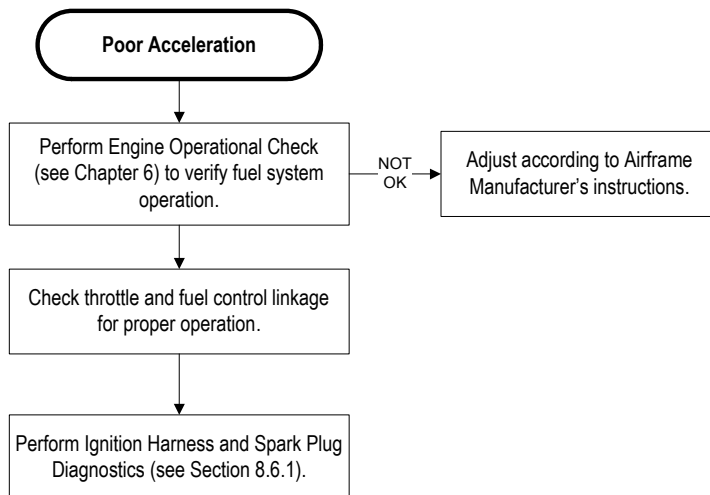



8-3.4. Fuel Injector Operational Check

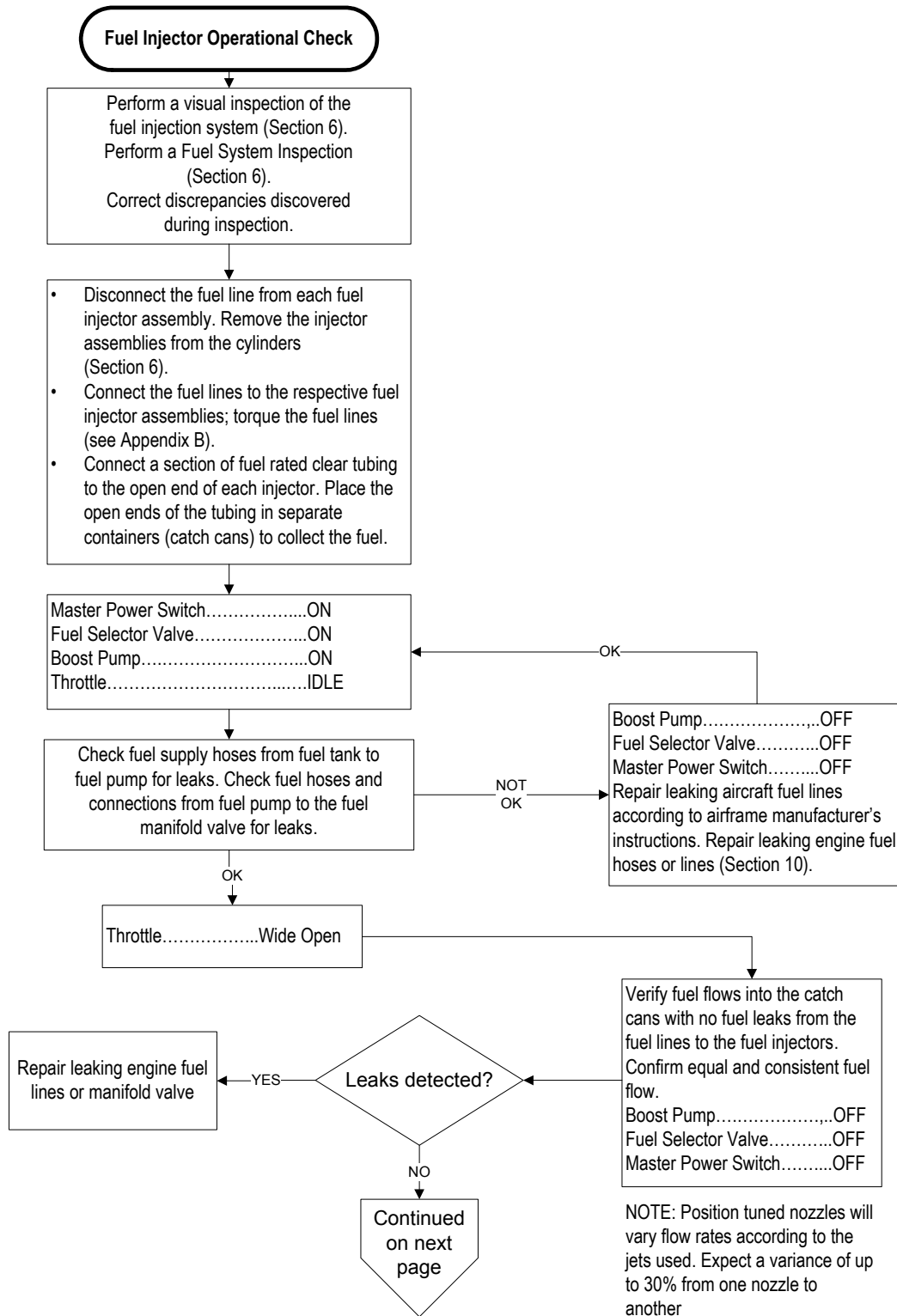

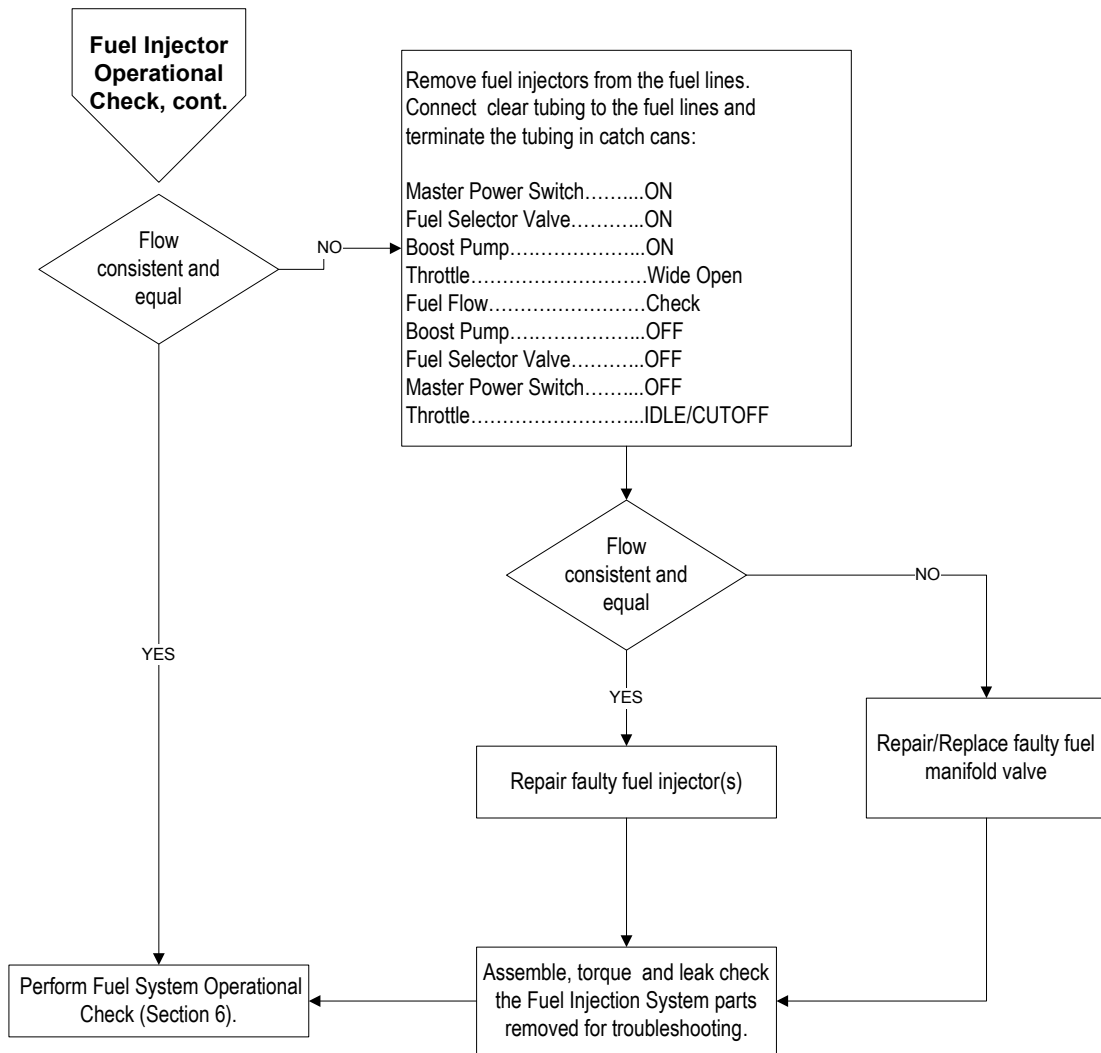



8-4. Charging System

Refer to the aircraft and alternator manufacturer’s applicable charging system troubleshooting instructions. If troubleshooting indicates the alternator is faulty, remove and replace the alternator according to the instructions in Section 10-4.

8-5. Starting System

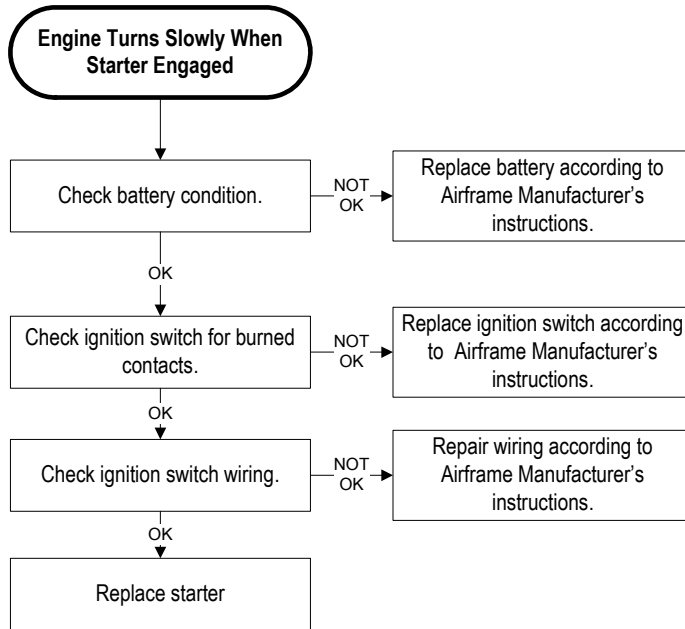
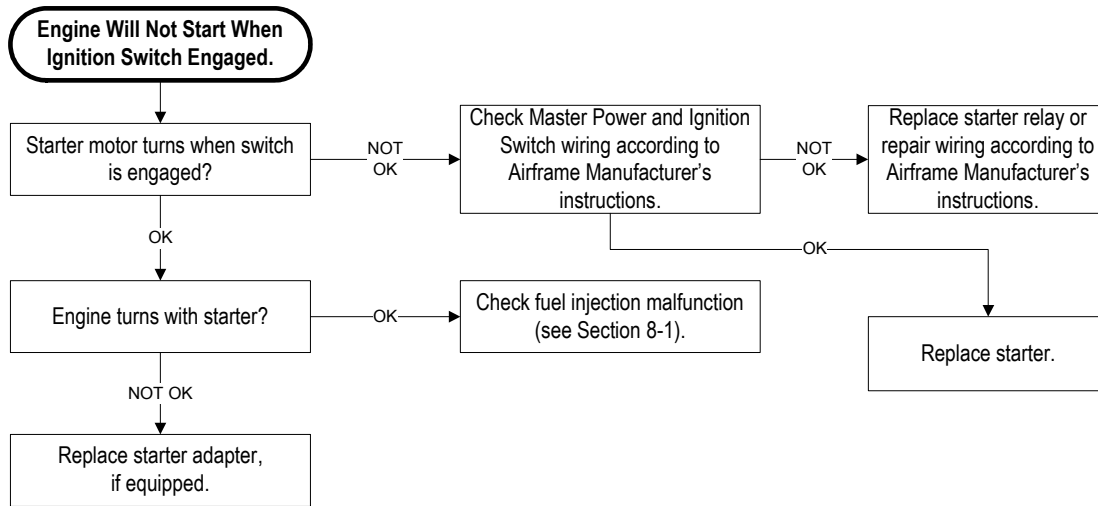



8-6. Ignition System

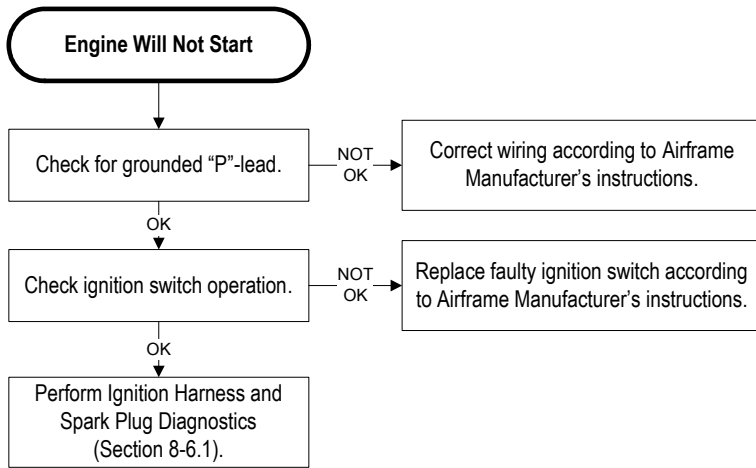



8-6.1. Ignition Harness and Spark Plug Diagnostics

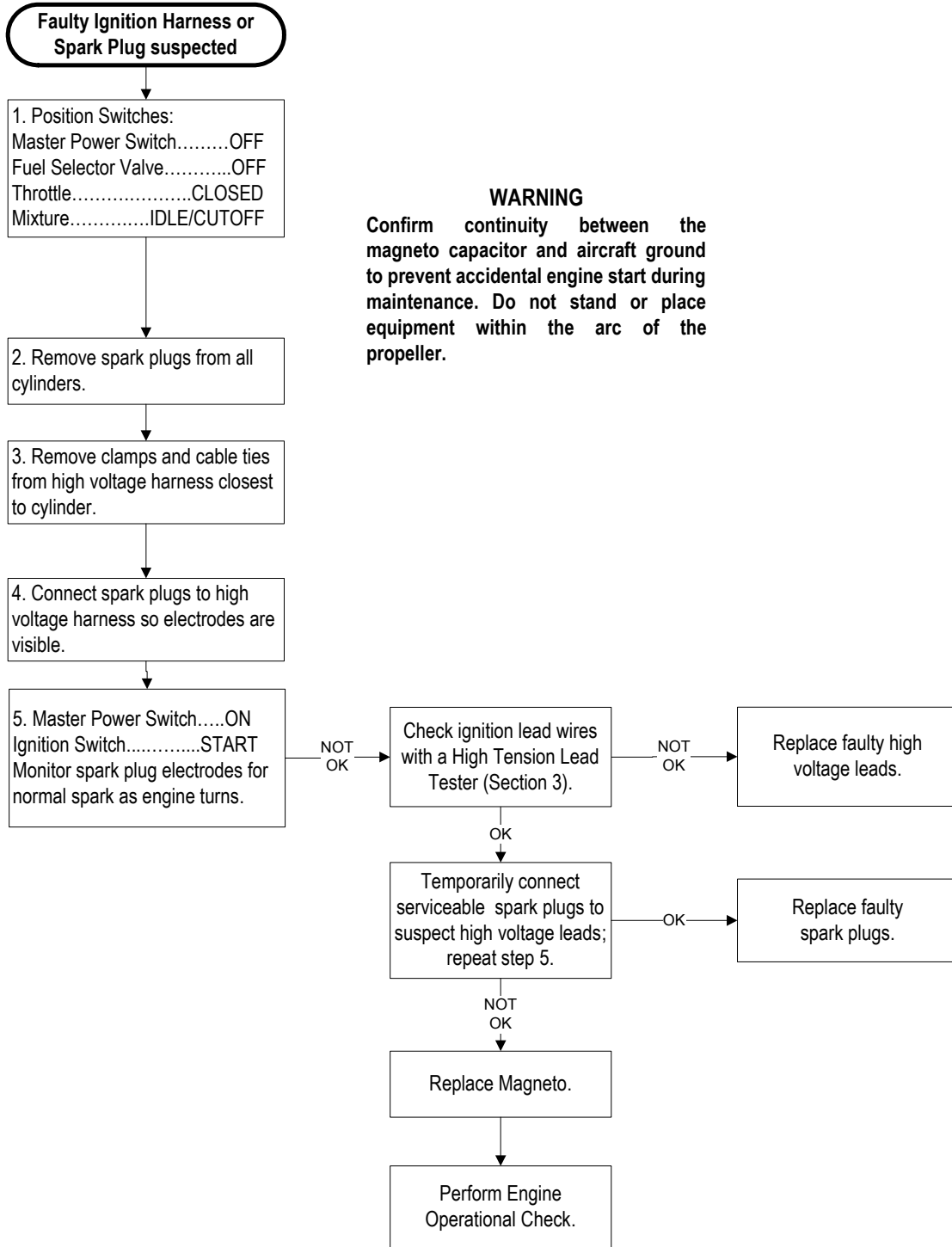



8-7. Lubrication System

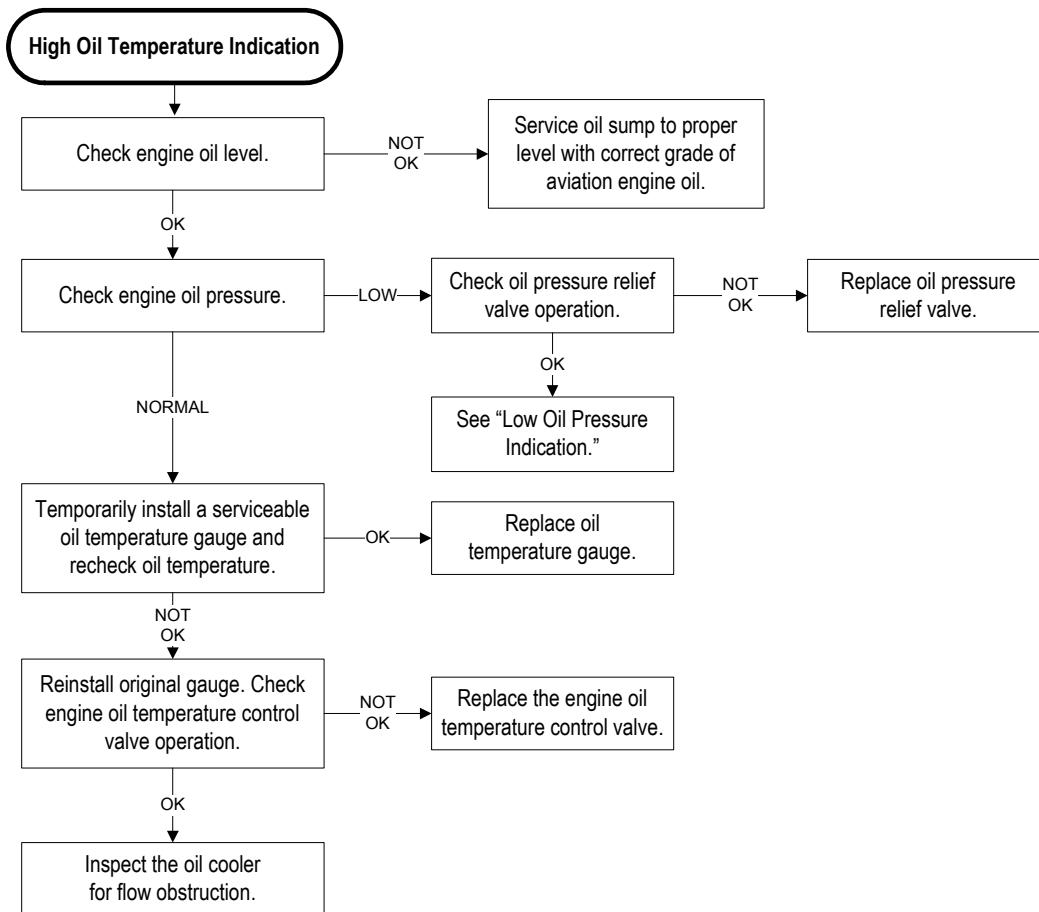
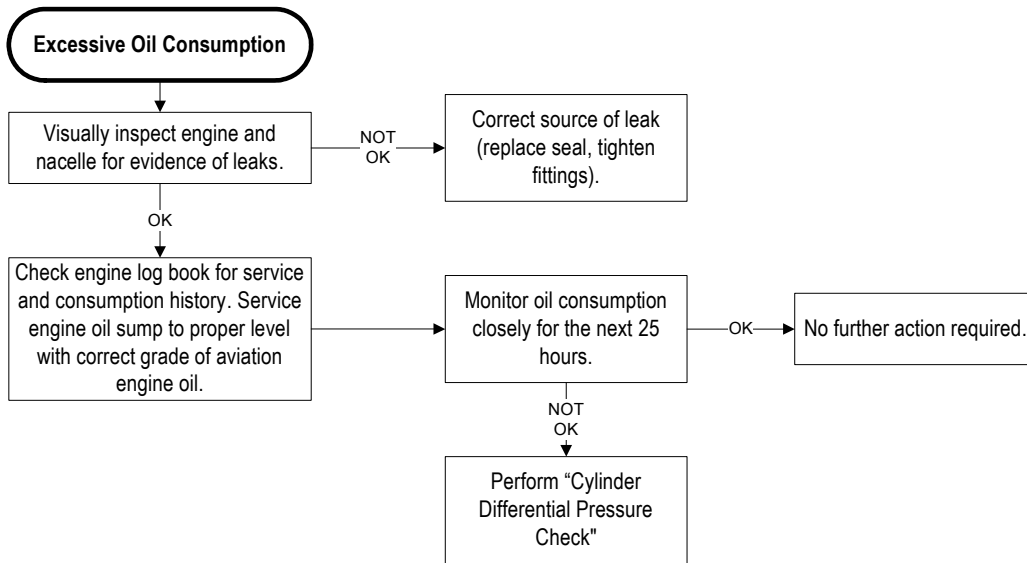



Troubleshooting

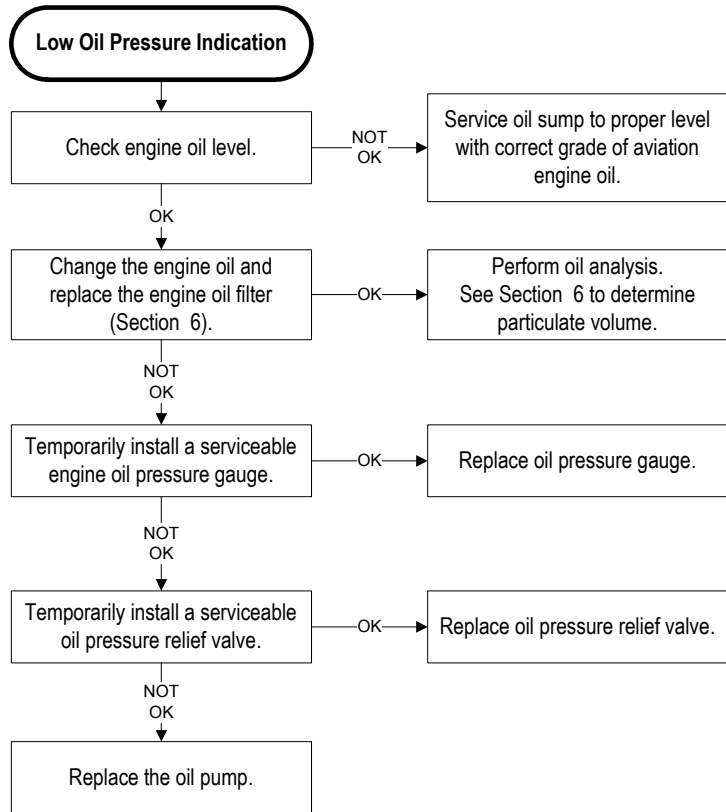



8-8. Engine Cylinders

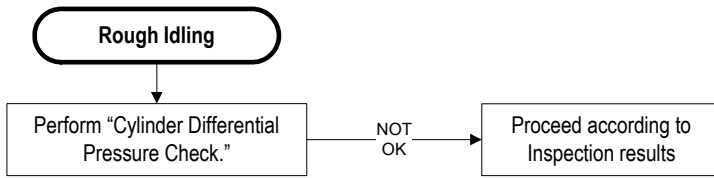



Troubleshooting

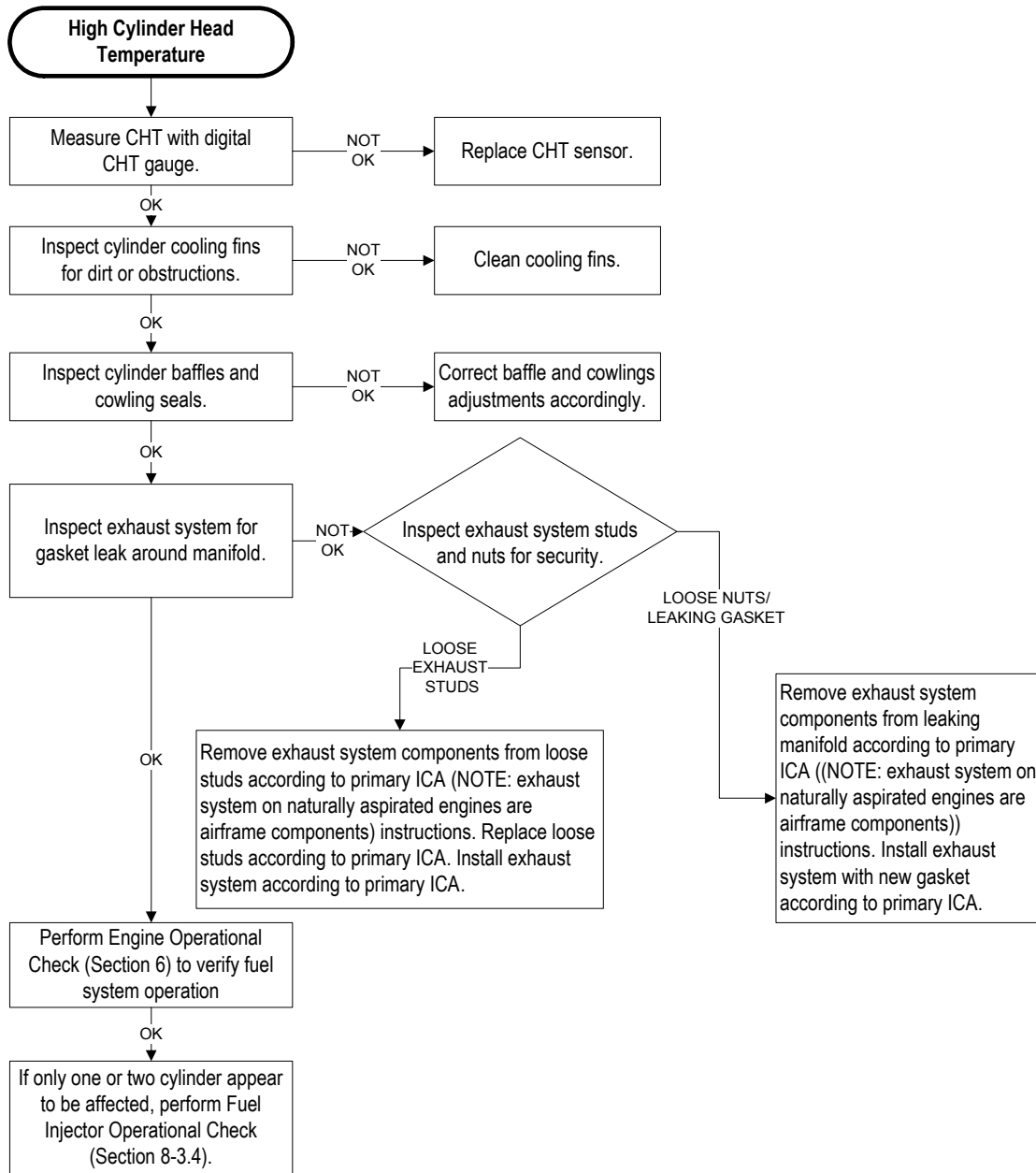



8-9. Crankcase

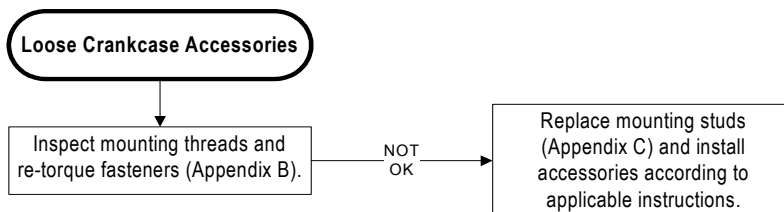
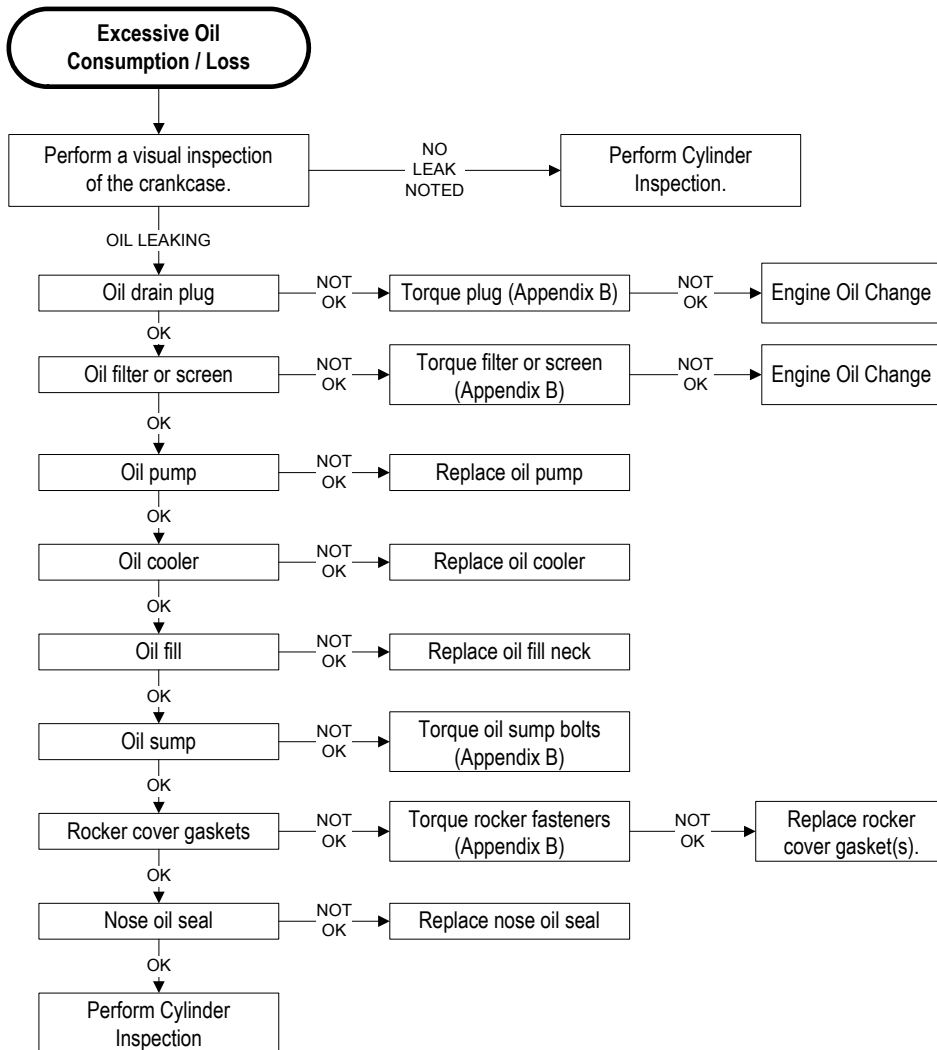



8-9.1. Excess Crankcase Pressure

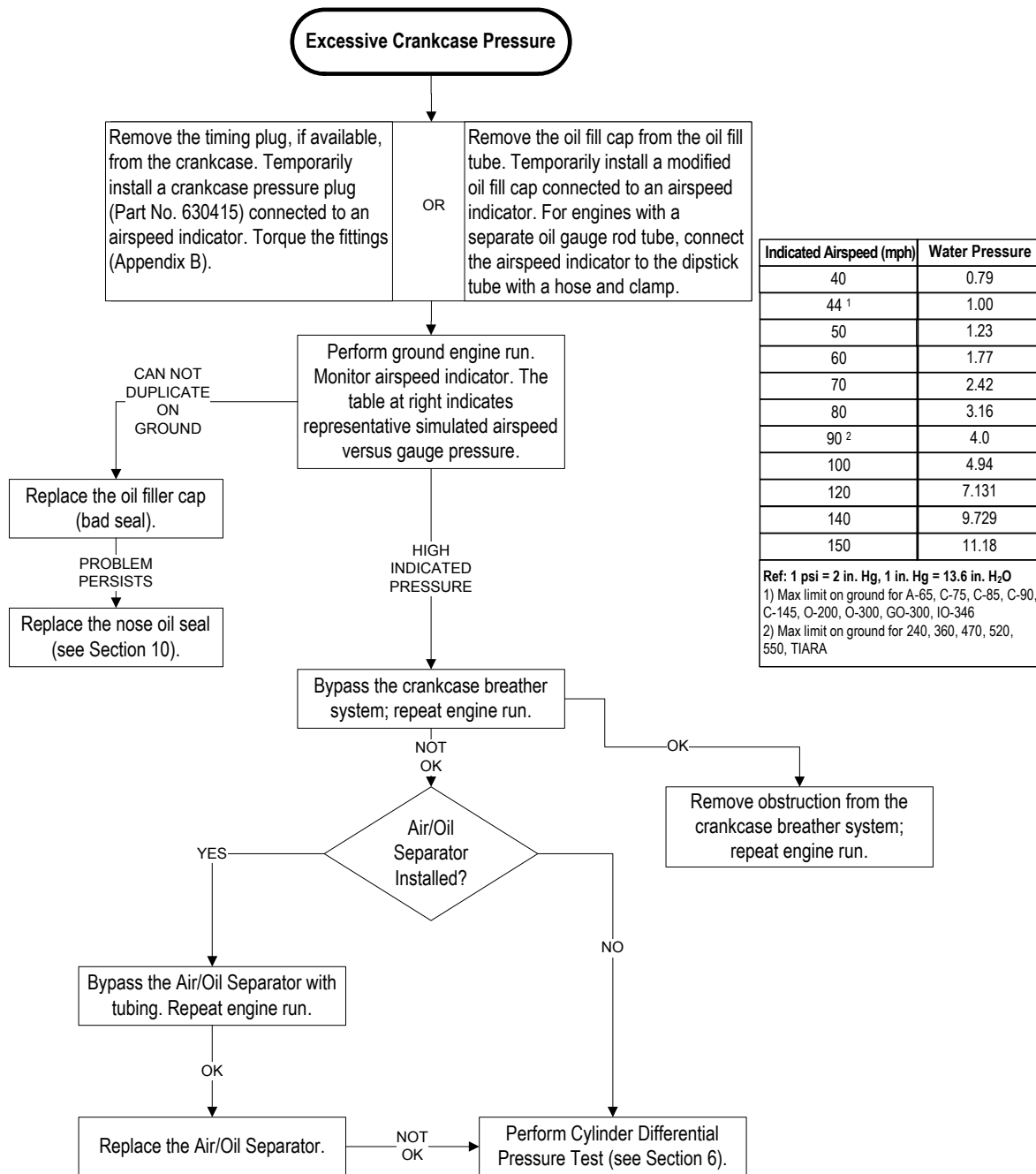



8-10. Turbocharger and Exhaust System

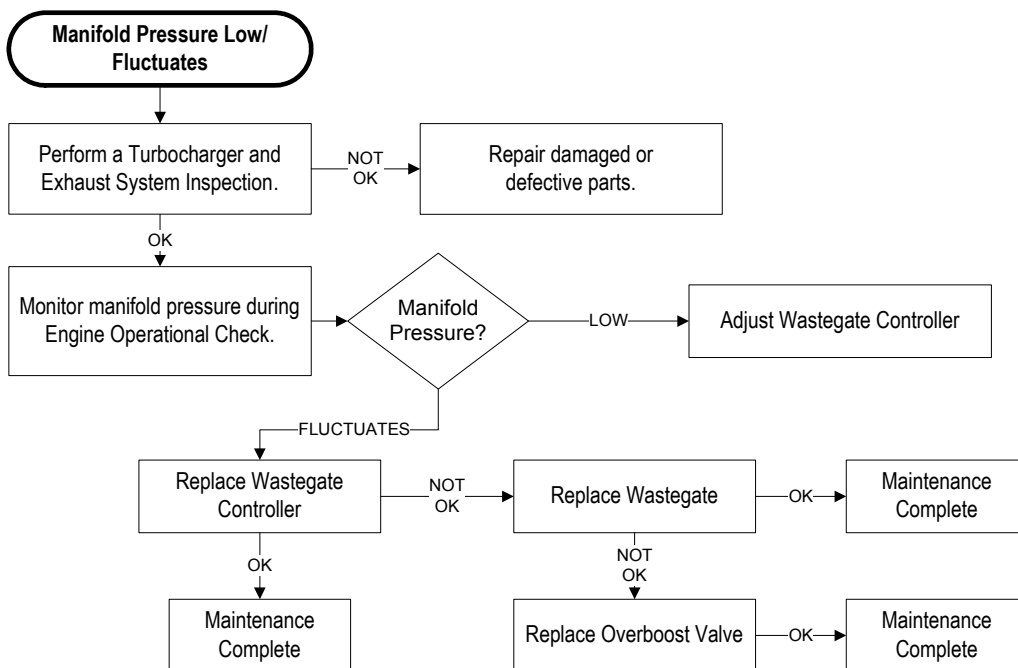
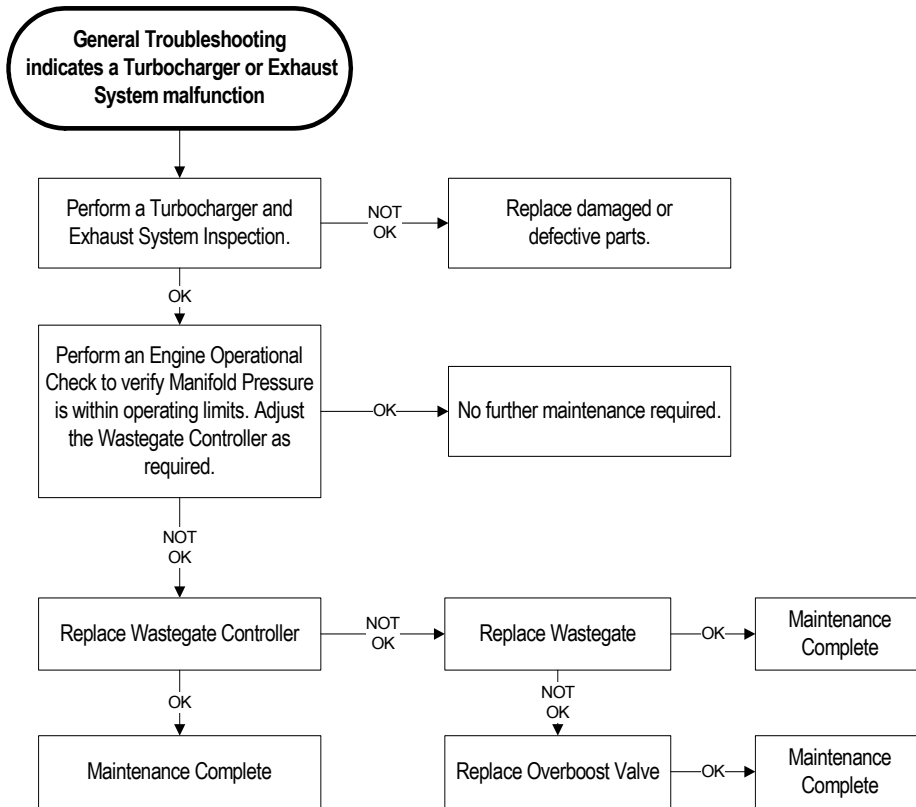



Intentionally Left Blank



Chapter 9. Engine Preservation and Storage

9-1. Preserving and Storing an Engine

An engine which has been uncrated and not installed and/or operated within 30 days after uncrating should be placed in storage. There are separate instructions for temporary (from 30 days up to 90 days) and indefinite (90 days or more) storage.

9-1.1. Engine Preservation Checklist

Make a copy of the checklist and record the serial number, date placed in storage and projected inspection dates for each engine placed in storage. The checklist covers a 90-day storage cycle. Complete a new checklist for each 90-day storage cycle and attach to the previous checklist to record inspections until the engine is returned to service.

9-1.2. New or Unused Engine Storage

1. Determine the projected length of storage and refer to the appropriate section for preservation instructions. If the engine storage period is:
 - a. 30- 90 days, follow the “Temporary Storage” instructions in Section 9-1.3.
 - b. greater than 90 days, follow the “Indefinite Storage” instructions in Section 9-1.4.
2. After preservation, cover the engine with a plastic bag.
3. Install and attach the container cover to the base (if not already done).

9-1.3. Temporary Storage

“Temporary Storage” is defined as a period of 30 to 90 days when the engine will not be used. If the storage period is likely to exceed 90 days, prepare the engine for indefinite storage according to instructions in Section 9-1.4.

1. Change the engine oil according to the “Engine Oil Servicing” in Section 6-4.8. Service the engine oil sump to the proper capacity with oil conforming to MIL-C-6529.

WARNING

If preheater are used to warm the engine, do not leave preheaters on for longer than 24 hours to prevent corrosion.

2. Perform a Preflight Inspection; correct any discrepancies noted.
3. Perform an “Engine Start” and “Ground Run-up” according to the instructions in Section 7-3.2 and Section 7-3.3, respectively.
4. Fly the aircraft for one hour at normal operating temperatures.
5. Allow the engine to cool after flight.
6. Disconnect and remove all spark plug leads.
7. Remove the top spark plugs from the engine; cover the ignition leads with AN-4060 protectors.



WARNING

Disconnect all spark plug leads, place the Throttle in the CLOSED position, set the brake and chock the aircraft wheels. Install aircraft tie-downs, Do not stand or place equipment within the arc of the propeller.

8. With the piston at the Bottom Dead Center position, use a common garden sprayer with clean reservoir and nozzle to spray atomized cylinder preservation oil that meets MIL-P-46002, through the top spark plug hole of each engine cylinder, with the pistons at bottom dead center. Rotate the crankshaft as opposite cylinders are sprayed.
9. Stop the crankshaft at a position where no pistons are at Top Dead Center.
10. Spray each cylinder again; thoroughly coat all interior cylinder surfaces by moving the nozzle from top to bottom of the cylinder while spraying. When all cylinders walls are thoroughly coated, ensure no piston is positioned at Top Dead Center.
11. Install the top spark plugs; do not install the spark plug leads.
12. Seal all engine openings exposed to the atmosphere using suitable plugs and covers. Attach a "REMOVE BEFORE FLIGHT" streamer to each location.
13. Attach a tag in a prominent location on the engine, preferably the propeller (or storage container, if installed) with the following information:

*DO NOT TURN PROPELLER - ENGINE PRESERVED
(preservation date)*

14. Indicate the status of new or rebuilt engines which have not been placed in service on the preservation tag.

NOTE: If the engine is not returned to service within 90 days of initial temporary storage, it must be preserved according to the "Indefinite Storage" instructions in Section 9-1.4.



9-1.4. Indefinite Storage

WARNING

Perform this procedure in an area free of sparks, flames, or other ignition sources.

1. Change the engine oil according to the “Engine Oil Servicing” in Section 6-4.8. Service the engine oil sump to the proper capacity with oil conforming to MIL-C-6529.

WARNING

If preheater are used to warm the engine, do not leave preheaters on for longer than 24 hours to prevent corrosion.

2. Perform an “Engine Start” and “Ground Run-up” according to the instructions in Section 7-3.2 and Section 7-3.3, respectively.
3. Perform a Preflight Inspection; correct any discrepancies noted.
4. Fly the aircraft for one hour at normal operating temperatures.
5. Allow the engine to cool after flight.

WARNING

Disconnect all spark plug leads, place the Throttle in the CLOSED position, set the brake and chock the aircraft wheels. Install aircraft tie-downs, Do not stand or place equipment within the arc of the propeller.

6. Disconnect and remove all spark plug leads.
7. Remove the top and bottom spark plugs from the engine and cover the ignition leads with AN-4060 protectors.
8. Install protective plugs (P/N 656816) in the bottom spark plug holes.
9. With the piston at the Bottom Dead Center position, use a common garden sprayer (with clean reservoir and nozzle) to spray atomized cylinder preservation oil that meets MIL-P-46002, through the top spark plug hole of each engine cylinder. Rotate the crankshaft as opposite cylinders are sprayed.
10. Spray each cylinder again; thoroughly coat all interior cylinder surfaces by moving the nozzle from top to bottom of the cylinder while spraying. When all cylinder walls are thoroughly coated, ensure no piston is positioned at Top Dead Center.
11. Install dehydrator plugs MS27215-1 or MS27215-2 in each of the top spark plug holes. Ensure that each dehydrator plug is dark blue in color when installed.
12. Attach a "REMOVE BEFORE FLIGHT" streamer tag to desiccant bags and place the tagged desiccant bag in the exhaust pipes. Seal the exhaust pipe openings.
13. Seal all other exposed engine openings with suitable plugs and covers. Attach “REMOVE BEFORE FLIGHT” streamers to installed plugs and covers.



Engine Preservation and Storage

14. Affix a readily visible tag to the propeller (or storage container, if installed) with the following information:

DO NOT TURN PROPELLER - ENGINE PRESERVED
(preservation date)

15. Indicate the status of new or rebuilt engines which have not been placed in service on the preservation tag.
16. Make a copy of Table 9-1 on page 9-5. Enter the serial number, storage date and next inspection due date on the form. Attach the form to the engine.
17. For indefinite storage, visually inspect the dehydrator plugs at 15-day intervals. Change the dehydrator plugs at the first indication (if any plug is not dark blue, replace the dehydrator plug) of color change. If more than half the dehydrator plugs change color, replace all desiccant material on the engine.
18. Repeat application of cylinder preservative application at 90 intervals.

9-1.5. Return an Engine to Service after Storage

1. Remove seals and desiccant bags.
2. Remove cylinder dehydrators (or plugs) from top and bottom spark plug holes.
3. Change the engine oil according to the “Engine Oil Servicing” in Section 6-4.8. Service the engine to the proper sump capacity with oil conforming to MIL-C-6529 Type II (Break-in oil, SAE J 1966 non-dispersant mineral oil).
4. Rotate propeller several revolutions by hand to remove preservative oil.
5. Remove AN-4060 protectors from the ignition leads.
6. Service and install spark plugs and leads according to the instructions in Section 6-4.9.2, “Spark Plug Maintenance” and Section 6-4.9.3, “Ignition Harness Maintenance”.
7. Clean and service engine and aircraft according to the Aircraft Manufacturer’s instructions. Perform a visual inspection and correct any discrepancies noted.
8. Perform a normal engine start according to the Airplane Flight Manual or Pilot’s Operating Handbook.
9. Conduct an “Engine Operational Check” according to instructions in Section 6-4.7; correct any discrepancies.
10. Perform a “Flight Check” according to instructions in Section 7-2.4; correct any discrepancies before releasing the aircraft for normal service.
11. Change engine oil and filter after first 25 hours of operation.



Table 9-1. Engine Preservation Checklist

Engine Serial Number:		Date Placed in Storage		
Inspection Item	Status	Inspection Due Date	Completion Date	Performed by
Engine preserved and stored according to the instructions in Section 9-1.4	<input type="checkbox"/> YES	N/A	/ /	
15 day inspection	<input type="checkbox"/> PASSED <input type="checkbox"/> CORRECTED	/ /	/ /	
30 day inspection	<input type="checkbox"/> PASSED <input type="checkbox"/> CORRECTED	/ /	/ /	
45 day inspection	<input type="checkbox"/> PASSED <input type="checkbox"/> CORRECTED	/ /	/ /	
60 day inspection	<input type="checkbox"/> PASSED <input type="checkbox"/> CORRECTED	/ /	/ /	
75 day inspection	<input type="checkbox"/> PASSED <input type="checkbox"/> CORRECTED	/ /	/ /	
90 day inspection	<input type="checkbox"/> PASSED <input type="checkbox"/> CORRECTED	/ /	/ /	
90 day cylinder treatment	<input type="checkbox"/> PASSED <input type="checkbox"/> CORRECTED	/ /	/ /	
Engine removed from storage	<input type="checkbox"/> COMPLETED	/ /	/ /	
<p>* Check condition of dehydrator plug for discoloration. Contents should be dark blue in color. If plugs are discolored, remove and replace with new plugs. If more than half the dehydrator plugs on the engine require replacement, remove and replace the desiccant bags in the exhaust pipes with fresh desiccant bags and reseal the exhaust pipe.</p> <p>** Treat each cylinder bore with MIL-P-46002. With the piston at the bottom dead center position, use a common garden sprayer (with clean reservoir and nozzle) to spray atomized cylinder preservation oil that meets MIL-P-46002, (at room temperature) through the top spark plug hole of each engine cylinder. Thoroughly cover all interior cylinder surfaces by moving the nozzle from top to bottom. Rotate the crankshaft as opposite cylinders are sprayed. Ensure no piston is positioned at top dead center.</p>				
Inspector Notes:				



Intentionally Left Blank



Chapter 10. Non-Overhaul Repair and Replacement

10-1. Parts Replacement

Procedures in this chapter apply to instances outside of overhaul when parts can be repaired or replaced as a maintenance practice; some parts cannot be repaired and must be replaced. Table 10-1, “Non-Overhaul Parts Replacement Reference” indicates items that must be replaced, along with respective references for replacement instructions. Table 10-2, the “Parts Repair Reference” lists items that may be repaired along with corresponding references to the repair instructions. Unless otherwise indicated, instructions are in this chapter.

WARNING

Turn the Ignition Switch OFF and disconnect engine electrical power before commencing maintenance or inspections. Confirm continuity between the magneto capacitor and aircraft ground to prevent accidental engine start during maintenance. Do not stand or place equipment within the arc of the propeller.

NOTE: When replacing components according to the maintenance procedures in this section, adhere to the *service limits*, in line with the procedure as a guide for part re-use for each component. Use the overhaul dimensional limits in the primary Instructions for Continued Airworthiness when performing maintenance repairs if service limits are not provided.

Service limits in this section apply only to maintenance procedures and in many cases are not identical to the overhaul limits in the primary Instructions for Continued Airworthiness (Section 1-1.1)

Table 10-1. Non-Overhaul Parts Replacement Reference

Replaceable Item	Reference Section
Alternator	Section 10-4, “Alternator Replacement”
Crankshaft Nose Oil Seal	Section 10-10, “Crankshaft Nose Oil Seal Replacement”
Fuel Injector Nozzles	Table 10-3 and Section 10-2, “Fuel Injector Replacement”
Induction Drain Connector	Section 10-3, “Induction Drain Connector Replacement”
Magneto	Section 10-5, “Magneto Replacement”
Oil Filter	Section 6-4.8, “Engine Oil Servicing”
Piston	Section 10-8, “Piston Replacement”



Non-Overhaul Repair and Replacement

Table 10-2. Parts Repair Reference

Repairable Item	Reference Section
Crankcase	Section 10-7, "Crankcase Repair"
Crankshaft Counterweights	Section 10-9, "Crankshaft Repair"
Cylinder	Section 10-6, "Cylinder Repairs"

Table 10-3. Parts Handling Guidelines

Parts/Components	Handling Instructions
Wrapped new or rebuilt parts	Parts that require protection from atmospheric dust and moisture should be wrapped or boxed after acceptance inspection and remain wrapped until time of installation
Spark plugs	Handle spark plugs with clean, dry hands. Avoid dropping a spark plug. If a spark plug is either dropped or damaged, discard it. Do not install any spark plug that has been dropped or damaged.



10-2. Fuel Injector Replacement

Refer to Section 10-2.1 for a brief explanation of fuel injector nozzle product identification. Removal Installation instructions vary for naturally aspirated and turbocharged engines. For naturally aspirated engines, refer to Section 10-2.4 and Section 10-2.5; for turbocharged engines use the instructions in Section 10-2.2 and Section 10-2.3.

NOTE: Continental Motors tests newly manufactured fuel injector nozzles and manifold valves as a set during the assembly process. Individual fuel injector nozzles may be replaced if unserviceable but we recommend replacement of injectors as a complete set to ensure proper distribution of fuel mixture to all cylinders and optimum engine performance.

10-2.1. Nozzle Identification

Continental Motors fuel injector nozzles have undergone two phases of redesign since 1998. Original nozzles were identified only by three-character nozzle size codes (Figure 10-1) (First Generation) on one or two of the hexagonal wrench flats.

The first redesign extended the identification to four-characters, including the installed cylinder position at the left-most character (Figure 10-1) (Second Generation) in the ID.

Fuel injector nozzles manufactured by Continental Motors after Dec 2005 are etched on four faces of the nozzle (Figure 10-1) (Third Generation). To select the proper replacement nozzles, you must first identify which generation of nozzle is installed. If the removed injectors do not conform to the new format, see Section 1-4.2 to cross-reference the correct replacement nozzle part number. A factory service representative can assist in determining the proper replacement nozzle based on the removed nozzle identification.

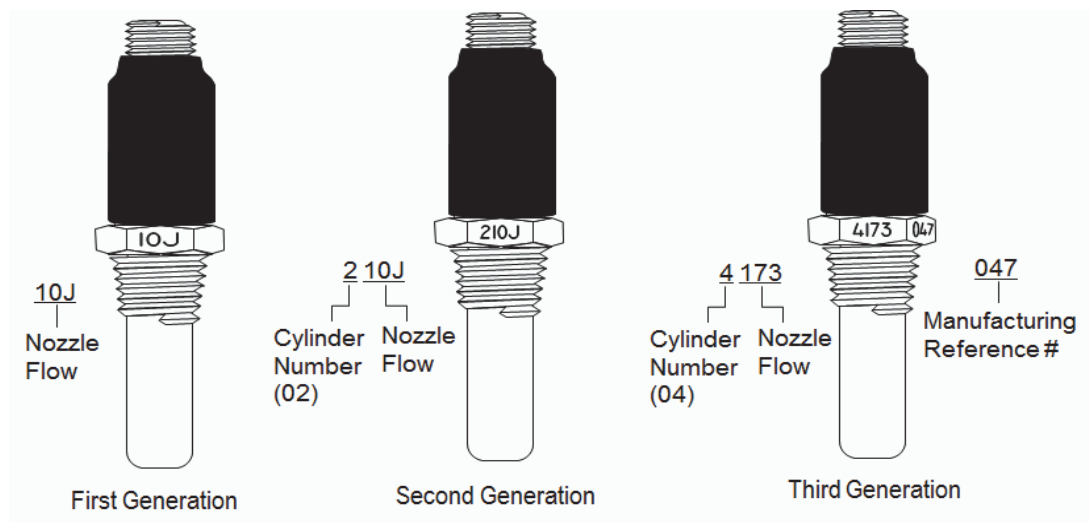

Figure 10-1. Fuel Injector Nozzle Identification (typical)

Observe the markings in Figure 10-1. A three digit numeric code identifies the nozzle orifice bore is stamped on two of the injector's hexagonal wrench flats – ignore this number! Adjacent to the three digit number, the injector is stamped on two of the hexagonal wrench flats with a four digit code indicating the cylinder position number and



Non-Overhaul Repair and Replacement

the nozzle flow; use this 4 digit number when assigning nozzles to cylinders. When ordering replacement nozzles, specify the position number and nozzle flow for each replacement nozzle required.

10-2.2. Fuel Injector Removal (Turbocharged engines)

WARNING

Turn the Ignition Switch OFF and disconnect engine electrical power before commencing maintenance or inspections. Confirm continuity between the magneto capacitor and aircraft ground to prevent accidental engine start during maintenance. Do not stand or place equipment within the arc of the propeller.

1. Turn the Ignition Switch to the OFF position and disconnect engine electrical power.
2. Remove airframe cowling, as required, to access the fuel injector nozzles.
3. Loosen the air reference sleeve “B” nuts (Figure 10-2) (2) from each reference sleeve (8) fitting on the common air for the side of the engine where the injector is being removed to allow the reference line freedom of movement. Remove and discard the seals (9).
4. Loosen “B” nuts on fuel lines (7), remove washers (5, 6); discard rubber washers (5).
5. Slide the reference sleeve (2) off the injector nozzle (1).
6. Remove fuel injector nozzles (1) with an Ideal Aviation Part No. 8167-IA (7/16”) or 8168-IA (1/2”) Injector Nozzle Removal/Installation Tool; remove and discard washers (4) and O-rings (3) from nozzle.
7. Place protective caps or plugs over the open fuel connections.
8. Note the nozzle identification and cylinder position for reinstallation or replacement.

10-2.3. Fuel Injector Installation (Turbocharged engines)

CAUTION: Ensure nozzle position numbers are matched to the appropriate cylinder. Installing incorrect nozzles or nozzles in the improper position will adversely affect engine performance.

1. Verify the cylinder position number (Figure 10-1) etched on the nozzle wrench flat matches the intended cylinder. If the nozzle is a replacement, the cylinder position number and nozzle flow must be a suitable for the intended cylinder position.
2. Purge the fuel system according to the “Fuel System Service” instructions in Section C-8 to prevent fuel system contamination prior to connecting each injector line to the fuel nozzle.
3. Apply clean, 50-weight aviation engine oil to a new washer (Figure 10-2) (4) and O-rings (3).
4. Install new washer (4) below the nut seat of the nozzle (1); apply a small amount of Part No. 646943 anti-seize lubricant to the nozzle according to Figure 3-1; hand tighten nozzle in the cylinder head; torque the nozzle with an Ideal Aviation Part No. 8167-IA (7/16”) or 8168-IA (1/2”) Injector Nozzle Removal/Installation Tool to Appendix B specifications.



5. Install new O-rings (3) on the nozzle (1).
6. Install the air reference sleeve (2) with a new rubber washer (5) and flat washer (6).
7. Install new compression seals (9) on the air reference line fittings and connect to the air reference sleeve “B” nuts. Torque the air reference sleeve “B” nuts to Appendix B specifications.
8. Connect the fuel lines to the fuel injector nozzles at each cylinder and torque the “B” nuts to Appendix B specifications.
9. Perform an “Engine Operational Check” according to the instructions in Section 6-4.7.

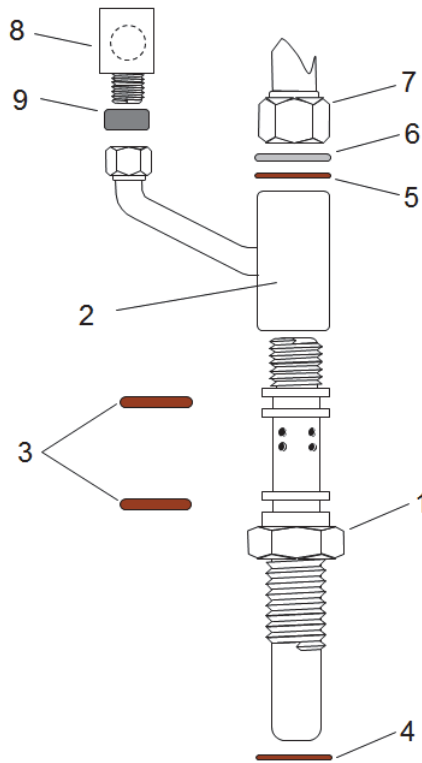

Figure 10-2. Turbo Fuel Injector Nozzle Assembly (typical)

1	Fuel Injector Nozzle	6	Washer
2	Air Reference Sleeve	7	Fuel Line
3	O-rings	8	Reference Line
4	Washer	9	Compression Seal
5	Rubber Washer		



10-2.4. Fuel Injector Removal (Naturally Aspirated engines)

WARNING

Turn the Ignition Switch OFF and disconnect engine electrical power before commencing maintenance or inspections. Confirm continuity between the magneto capacitor and aircraft ground to prevent accidental engine start during maintenance. Do not stand or place equipment within the arc of the propeller.

1. Disconnect engine electrical power and turn the Ignition Switch to the OFF position.
2. Remove airframe cowling, as required, to access the fuel injector nozzles.
3. Loosen “B” nuts on fuel lines.
4. Remove fuel injector nozzles (1) with an Ideal Aviation Part No. 8167-IA (7/16”) or 8168-IA (1/2”) Injector Nozzle Removal/Installation Tool; remove and discard washers (4) and O-rings (3) from nozzle.
5. Place protective caps or plugs over the open fuel connections.
6. Note the nozzle identification and cylinder position for reinstallation or replacement.

10-2.5. Fuel Injector Installation (Naturally Aspirated engines)

CAUTION: Ensure nozzle position numbers are matched to the appropriate cylinder. Installing incorrect nozzles or nozzles in the improper position will adversely affect engine performance.

1. Verify the cylinder position number (Figure 10-1) etched on the nozzle wrench flat matches the intended cylinder. If the nozzle is a replacement, the cylinder position number and nozzle flow must be a suitable for the intended cylinder position.
2. Purge the fuel system according to the “Fuel System Service” instructions in Section C-8 to prevent fuel system contamination prior to connecting each injector line to the fuel nozzle.

NOTE: There are three types of fuel injector nozzles used on naturally aspirated engines. The screens and shields (Figure 10-3) on the short reach nozzles are pressed in place on the injector nozzle and need not be disassembled. The long reach nozzles on IO-550-G, N, P & R engines are press fit with an O-ring installed on the upper flange. The O-ring must be replaced after cleaning. Long reach injector nozzles on the remaining fleet of naturally aspirated engines do not utilize an O-ring.

3. For IO-550-G, N, P & R model engines only, if fuel injectors were removed and cleaned, new O-rings (Figure 10-3) are required prior to installation. Apply clean, 50-weight aviation engine oil to the new O-ring and install one O-ring in the groove at the top of the fuel injector nozzle. Install the screen and shroud over the upper portion of the fuel injector nozzle.
4. For IO-550-G, N, P & R engines only, install a new copper washer at the base of each injector nozzle.



5. Apply a small amount of Part No. 646943 anti-seize lubricant to the nozzle according to Figure 3-1; hand tighten nozzle in the cylinder head; torque the nozzle with an Ideal Aviation Part No. 8167-IA (7/16") or 8168-IA (1/2") Injector Nozzle Removal/Installation Tool to Appendix B specifications.

NOTE: The "B" nut connection is a dry seal. Do not apply any sealant to the threads of the tapered fitting of the fuel injector nozzle or the "B" nut. Reference Figure 3-2.

6. For IO-550-G, N, P & R engines only, install a new rubber washer followed by a steel washer at the fuel inlet of each injector nozzle.
7. Connect the fuel line "B" nut to the fuel injector nozzle and torque to Appendix B specifications.
8. Perform a normal "Engine Start" and "Ground Run-up" according to the aircraft AFM/POH. Allow the engine to run-for no more than five minutes and inspect the fuel injectors for leaks after "Engine Shutdown".

CAUTION: Some early versions of the IO-550-G, N, P & R long reach fuel injector nozzles feature two O-ring shoulders (groove). At the time of assembly, install an O-ring only in the top groove.

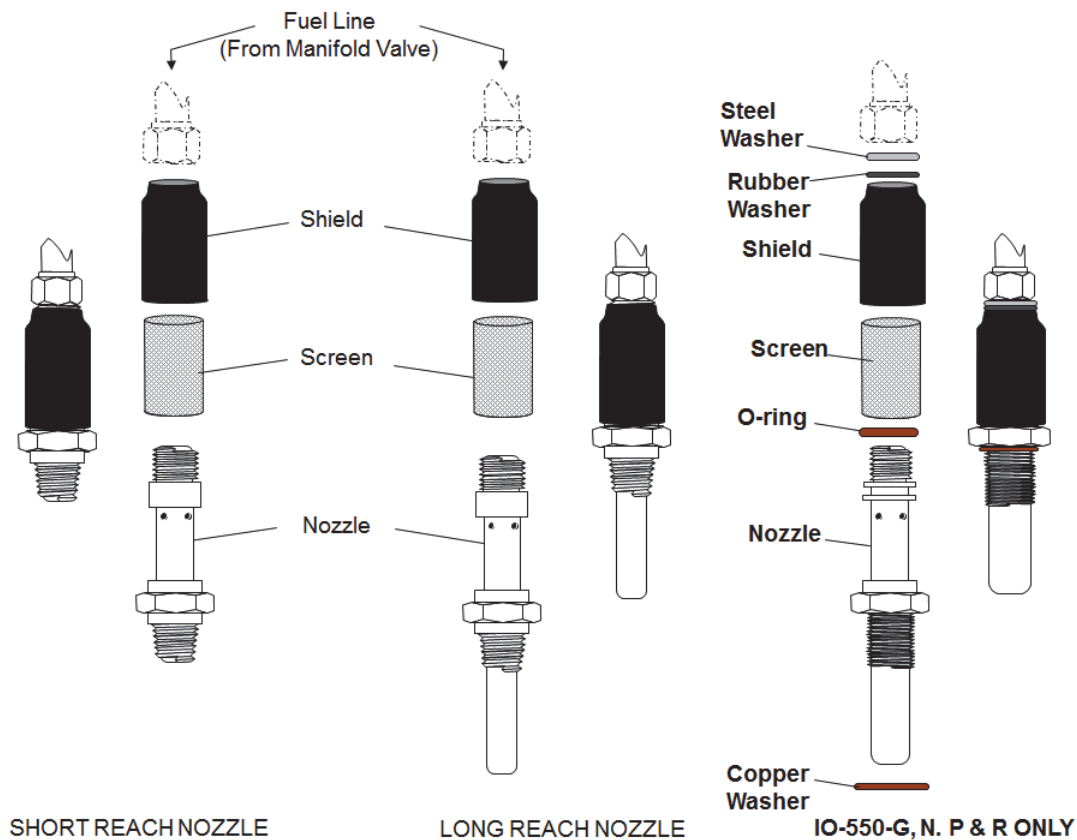

Figure 10-3. Naturally Aspirated Engine Fuel Injector Nozzles



10-3. Induction Drain Connector Replacement

Crossflow (induction ports above; exhaust ports below) cylinders are designed with a tapped boss below the intake valve in the cylinder head. A connector, installed in the tapped boss allows excess fuel to drain from the intake to avoid a hydraulic lock condition. Updraft (intake and exhaust ports below the cylinder) cylinders incorporate induction drains in the induction tubes. Instructions in the section apply to the crossflow cylinders only.

10-3.1. Induction Drain Connector Removal and Cleaning

1. Disconnect the cylinder drain tubes from the connector fittings on the bottom side of each cylinder head according to instructions in the Maintenance and Overhaul (or Overhaul) Manual.
2. Remove the connector fitting (Figure 6-95) from each cylinder head. Visually inspect the connector threads for physical damage; replace faulty connectors.
3. Clean connector fittings by immersion in lacquer thinner for several hours.
 - a. Stubborn stains may be polished with a fine nylon (Scotch Brite) scouring pad.
 - b. Inspect the weep hole for varnish buildup obstructions; if the weep hole is clogged, a small piece of 0.020" safety wire may be passed through the hole to free the clog.
 - c. Allow the cleaned connector fittings to air dry.
4. If cleaning is unsuccessful, replace the connector fitting.

10-3.2. Induction Drain Connector Installation

1. Sparingly apply Part No. 646940 F/I sealant to the tapered male threads of the connector.
2. Install the connector fitting in the cylinder head; torque 60-80 in. lbs. (reference Appendix B specifications).
3. Connect cylinder drain tubes to the connector fittings with new seals according to the instructions in the Maintenance and Overhaul (or Overhaul) Manual.



10-4. Alternator Replacement

Replace the alternator when it fails to deliver the correct voltage and amperage to the aircraft electrical system. If electrical malfunctions are isolated to the alternator, physical inspection of the alternator must be accomplished before replacement. The engine may be equipped with a direct drive alternator, a belt-driven alternator, or both. For Continental Motors alternators, refer to Table 1-2 for the appropriate instructions to service or overhaul the alternator. Consult Section 10-4.3 for applicable continued airworthiness instructions or replace the alternator with a new, rebuilt, or serviceable alternator during the 500 hour inspection.

On all GTSIO-520 and All 520 and 550 series engines with a Permold crankcase, a gear driven alternator pad, forward of the No. 5 cylinder is driven off the crankshaft face gear. In this manual, these alternators are designated as **FWD**. See Section 10-4.1 for removal and installation instructions. C-75, C-85, C-90, C-115, C-125, C-145, E-165, E-185, E-225, O-200, GO-300, GIO-300, O-300, IO-240, IOF-240, and all 360 series engines feature an alternator mounting pad on the accessory case, driven off the camshaft gear. These alternators are designated as **AFT** in this manual; see Section 10-4.2 for removal and installation instructions.

10-4.1. Gear Driven Alternator Replacement, Forward Mount **FWD**

10-4.1.1. Gear Driven Alternator Removal **FWD**

Applicable Engines:

IO-520-B, BA, BB, C, CB, M, MB, NB, TSIO-520-B, BB, BE, D, DB, E, EB, J, JB, K, KB, L, LB, N, NB, UB, VB, WB, IO-550-A, B, C, G, N, P, R, IOF-550-N, P, R, TSIO-550-B, C, E, G, K, N, TSIOF-550-D, J, K, P, TSIOL-550, A, B, C

WARNING

Turn the Ignition Switch OFF and disconnect engine electrical power before commencing maintenance or inspections. Confirm continuity between the magneto capacitor and aircraft ground to prevent accidental engine start during maintenance. Do not stand or place equipment within the arc of the propeller.

1. Turn the Ignition Switch to the OFF position and disconnect engine electrical power.
2. Disconnect the aircraft battery according to the aircraft manufacturer's instructions.
3. Disconnect electrical connections from the alternator according to the aircraft manufacturer's instructions.
4. Remove the nut (Figure 10-4) (10), washer (8), lock washer (9), and from the four alternator mounting studs; discard the lock washers (9).
5. Remove the alternator (2) from the crankcase mounting studs.

CAUTION: Exercise care when cleaning the residue from the mounting flange; mask the crankcase opening to avoid contaminating the engine oil supply.



Non-Overhaul Repair and Replacement

6. Remove and discard the gasket (1); clean any remaining gasket residue from the crankcase flange with lacquer thinner.
7. Place the alternator in a horizontal position, rotate the shaft in both direction. If the shaft does not turn freely, rotor friction or bearing stress is indicated, or noticeable shaft displacement is detected during rotation, replace the alternator.
8. Perform a “Gear Tooth Inspection” on the alternator drive hub gear according to the instruction in Section 11-1.1. If the drive hub gear teeth are chipped, broken, or otherwise damaged, replace the drive hub according to instructions in Section 10-4.1.2 and perform a “Foreign Object Contamination Inspection” according to instructions in Section 6-5.7.
9. Inspect the drive hub coupling for serviceability. If the coupling exhibits damage or missing material, replace the drive hub and perform a “Foreign Object Contamination Inspection” according to instructions in Section 6-5.7.
10. Perform a “Gear Tooth Inspection” on the alternator drive hub gear according to the instruction in Section 11-1.1. If the face gear teeth are chipped, broken, or damaged, disassemble the engine and replace the crankshaft face gear.
11. Perform an “Alternator Drive Hub Inspection” according to instructions in Section 6-4.22.1.

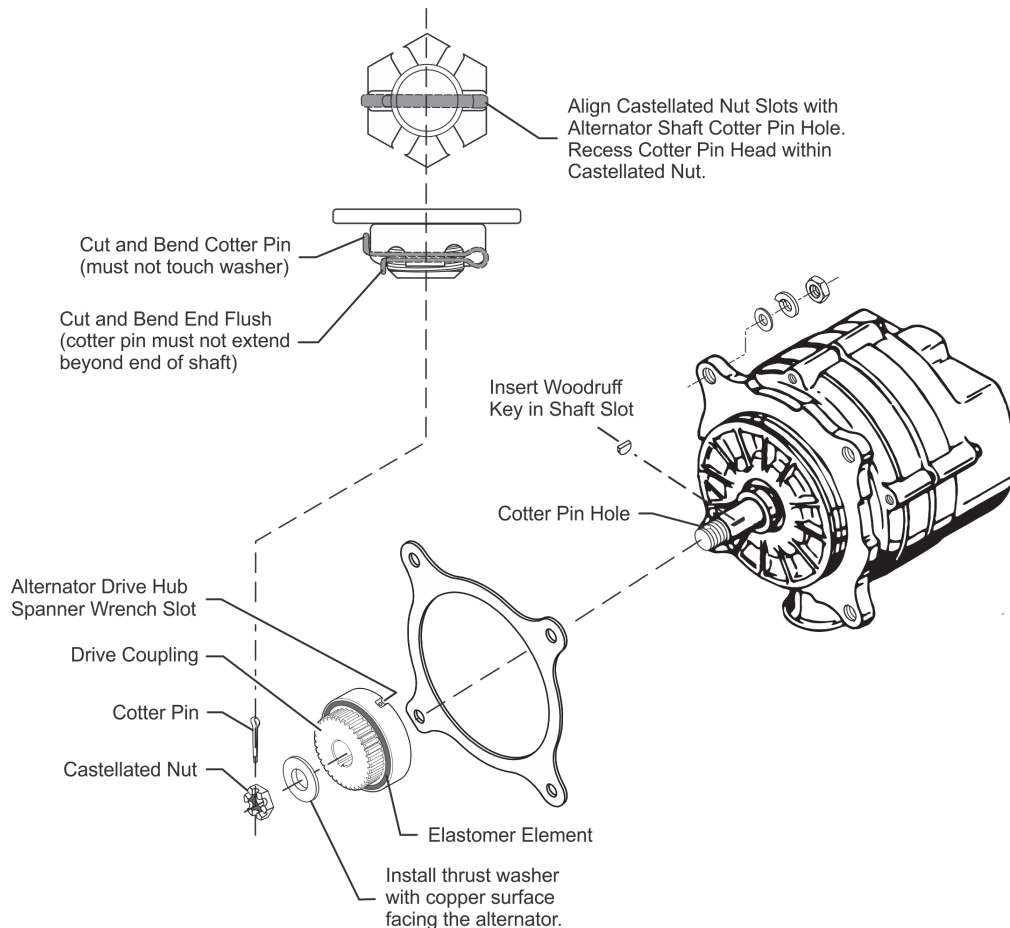

Figure 10-4. Alternator and Drive Hub



10-4.1.2. Alternator Drive Hub Removal **FWD**

Applicable Engines:

IO-520-B, BA, BB, C, CB, M, MB, NB, TSIO-520-B, BB, BE, D, DB, E, EB, J, JB, K, KB, L, LB, N, NB, UB, VB, WB, IO-550-A, B, C, G, N, P, R, IOF-550-N, P, R, TSIO-550-B, C, E, G, K, N, TSIOF-550-D, J, K, P, TSIOL-550, A, B, C

1. Remove the alternator from the crankcase according to the instructions in Section 10-4.1.1.

CAUTION: Remove and discard the spring coupling (Part No. 6409333 or 640934) if installed on the alternator. The elastomer coupling superseded the spring couplings.

2. Remove and discard the cotter pin (Figure 10-4) (7) and remove the castellated nut (4).
3. Pull the drive hub assembly (5) from the alternator shaft.
4. Remove and discard the Woodruff key (3).
5. Separate the thrust washer (6) and drive hub assembly (5).
6. Inspect, disassemble, troubleshoot, repair, and assemble Continental Motors alternators according to the Alternator Service Instruction (X30531). If the alternator is manufactured for CM by Hartzell Engine Technologies, consult Section 10-4.3 for applicable airworthiness instructions. For all other alternators, replace the alternator with a new, rebuilt, or serviceable unit.

10-4.1.3. Alternator Drive Hub Installation **FWD**

Applicable Engines:

IO-520-B, BA, BB, C, CB, M, MB, NB, TSIO-520-B, BB, BE, D, DB, E, EB, J, JB, K, KB, L, LB, N, NB, UB, VB, WB, IO-550-A, B, C, G, N, P, R, IOF-550-N, P, R, TSIO-550-B, C, E, G, K, N, TSIOF-550-D, J, K, P, TSIOL-550, A, B, C

WARNING

If the shipping washer is not removed prior to installing the drive hub assembly, the shipping washer will interfere with the crankshaft face gear and damage the engine and alternator.

1. Remove the shipping spacer and washer from the alternator shaft and discard to prevent interference with the crankshaft face gear.
2. Inspect the drive hub for slippage according to the instructions in Section 10-4.1.4.

NOTE: A new Woodruff key is included with new alternators; Woodruff key replacement is not required for new alternators.

3. Install a new Woodruff key (Figure 10-4) (3).

WARNING

The special thrust washer (6) must be installed with the bearing surface (copper color) toward the alternator.



Non-Overhaul Repair and Replacement

4. Install the drive hub assembly (5), and new thrust washer (6) on the alternator shaft.
5. Install the castellated nut (4) on the shaft. Secure the drive hub with an Alternator Drive Hub Spanner Wrench (see Section 2-1, “Special Tools”.) and torque the castellated nut (4) to the minimum value specified in Appendix B.
6. If the slots of the nut do not align with the cotter pin hole in the alternator shaft, the castellated nut may be torqued up to the maximum value in Appendix B. If the cotter pin holes will not align with the nut slot within the torque range, replace the nut.
7. Install the new cotter pin (7) according to the “Cotter Pin Installation” instructions in Section C-7, cut and bend the cotter pin according to the illustration in Figure 10-4 to prevent it from touching the thrust washer and to attain clearance when installing the alternator on the engine.
8. Install the alternator according to “Gear Driven Alternator Installation” instructions in Section 10-4.1.5.

10-4.1.4. Alternator Drive Hub Slippage Inspection **FWD**

NOTE: There is no need to remove the drive hub from the alternator. The spanner wrench is designed to secure the drive hub without removing it from the shaft.

1. Secure the alternator in a shielded vise only tight enough to prevent movement.

CAUTION: Secure only the outer diameter of the drive hub assembly; allow the gear freedom of movement to prevent shearing the elastomer coupling.

2. Secure the alternator drive hub with an “Alternator Drive Hub Spanner Wrench (Table 2-1); adjust the bolts using finger pressure only - do not torque the bolts.

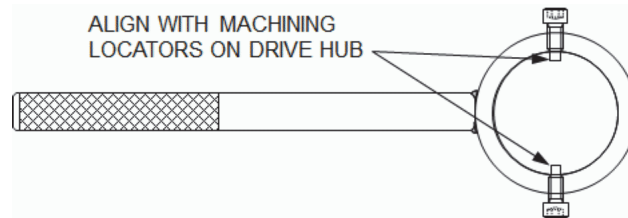

Figure 10-5. Alternator Drive Hub Spanner Wrench

3. Measure the drive hub assembly slippage using an “Alternator Drive Hub Torque Tool” (Figure 2-5) and a currently calibrated torque wrench set to value for the drive hub condition specified in Table 10-4. Turn the hub through a 45° arc at a rate of 1° to 2° per second. No slippage is permitted below the value specified in Table 10-4.
4. If the coupling slips with less torque applied than the value specified in Table 10-4, or the coupling exhibits physical damage, discard and replace the alternator elastomer drive coupling and repeat the slippage check on the new drive coupling.

Table 10-4. Alternator Drive Hub Slippage

Coupling Assembly Condition	Slippage Prohibited Below:
New coupling or coupling with less than 25 hours in service	180 in-lbs.
Coupling with more than 25 hours in service	140 in-lbs.



10-4.1.5. Gear Driven Alternator Installation **FWD**

Applicable Engines:

IO-520-B, BA, BB, C, CB, M, MB, NB, TSIO-520-B, BB, BE, D, DB, E, EB, J, JB, K, KB, L, LB, N, NB, UB, VB, WB, IO-550-A, B, C, G, N, P, R, IOF-550-B, C, N, P, R, TSIO-550- B, C, E, G, K, N, TSIOF-550-D, J, K, P, TSIOL-550, A, B, C

Prior to alternator installation, perform an “Alternator Drive Hub Slippage Inspection” in Section 10-4.1.4 and install a serviceable drive hub according to instructions in Section 10-4.1.3.

WARNING

Turn the Ignition Switch OFF and disconnect engine electrical power before commencing maintenance or inspections. Confirm continuity between the magneto capacitor and aircraft ground to prevent accidental engine start during maintenance. Do not stand or place equipment within the arc of the propeller.

CAUTION: If the removed alternator exhibited gear tooth or elastomer coupling damage, the engine must be inspected for foreign object contamination prior to installing a new alternator.

1. Turn the Ignition Switch to the OFF position and disconnect engine electrical power.
2. Perform a “Gear Tooth Inspection” on the alternator face gear according to the instruction in Section 11-1.1. If the face gear teeth are chipped, broken, or damaged, disassemble the engine and replace the crankshaft face gear.
3. Install a new gasket on the alternator mounting studs.
4. Install the alternator on the mounting studs using four *new* lock washers, four plain washers and four nuts. Torque the nuts to 150-180 in. lbs. in an alternating cross pattern.
5. If the alternator had a grounding strap when it was removed, install the grounding strap when installing the alternator.
6. Reconnect electrical connections at the alternator according to the aircraft manufacturer’s instructions.
7. Consult the aircraft maintenance manual for instructions to reconnect ram air ducts, if equipped, for alternator cooling air.
8. Reconnect the aircraft battery according to the aircraft manufacturer’s instructions.
9. Start the engine (“Engine Start” instructions in Section 7-3.2) and test the alternator output according to the instructions in the Aircraft Maintenance Manual.



10-4.2. Gear Driven Alternator Replacement, Aft Mount **AFT**

Applicable Engines:

C-75, C-85, C-90, C-115, C-125, C-145, E-165, E-185, E-225, GO-300, GIO-300, O-200, O-300, IO-240, IOF-240, and all IO-360, LTSIO-360, TSIO-360

10-4.2.1. Gear Driven Alternator Removal **AFT**

WARNING

Turn the Ignition Switch OFF and disconnect engine electrical power before commencing maintenance or inspections. Confirm continuity between the magneto capacitor and aircraft ground to prevent accidental engine start during maintenance. Do not stand or place equipment within the arc of the propeller.

1. Turn the Ignition Switch to the OFF position and disconnect engine electrical power.
2. Disconnect the aircraft battery according to the aircraft manufacturer's instructions.
3. Disconnect electrical connections from the alternator according to the aircraft manufacturer's instructions.

NOTE: The alternator gasket on 360 series engines is NOT integrated with the tachometer drive adapter gasket.

4. For 360 series engines, proceed to the next step. On C-Series, O-200, IO-240, IOF-240 series engines *only*, remove the tachometer drive adapter, or tachometer drive adapter pad cover, depending on, configuration, according to instructions in the primary ICA (**Ref: Section 1-1.1**).
5. Remove three lock nuts (Figure 10-6) (8) and washers (7) from the three alternator mounting studs. Discard the lock nuts (8).
6. Remove the alternator (1) from the accessory case mounting studs.

CAUTION: Exercise care when cleaning the residue from the mounting flange. Mask the accessory case opening to avoid contaminating the engine oil supply.

7. Remove the gasket (6) and clean any remaining gasket residue from the accessory case with lacquer thinner.
8. Rotate the crankshaft through two revolutions to perform a "Gear Tooth Inspection" on the camshaft gear according to instruction in Section 11-1.1. If the camshaft gear teeth are damaged, disassemble the engine and replace the camshaft gear.
9. Inspect the drive hub coupling for serviceability. If the coupling exhibits damage or missing material, replace the drive hub and perform a "Foreign Object Contamination Inspection" according to instructions in Section 6-5.7.
10. Place the alternator in a horizontal position, rotate the shaft in both direction. If the shaft does not turn freely, rotor friction or bearing stress is indicated, or noticeable shaft displacement is detected during rotation, replace the alternator.

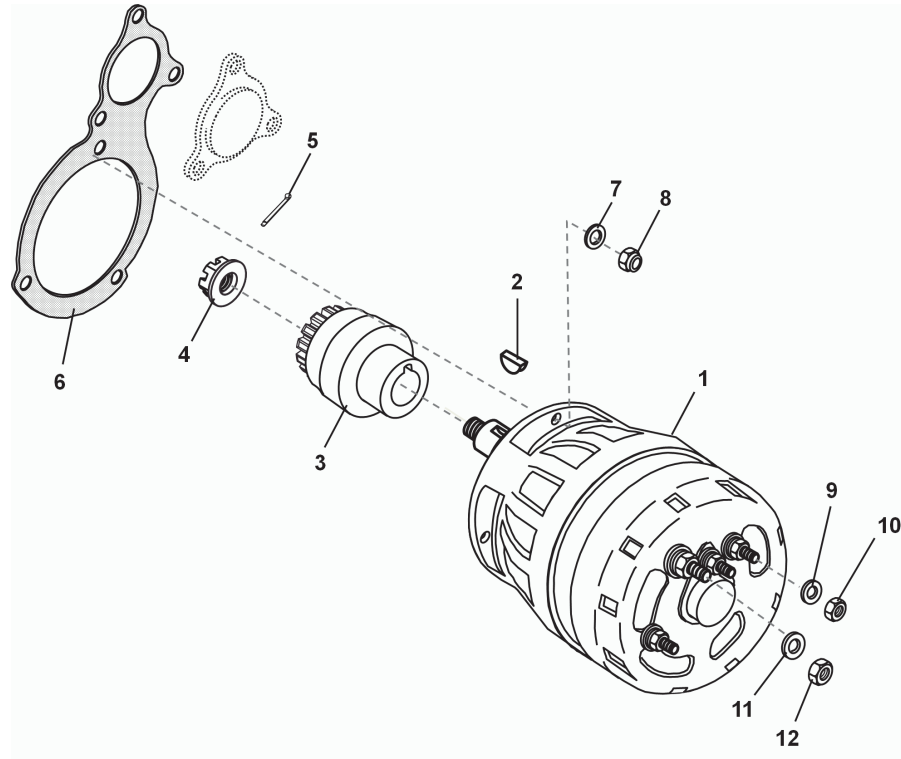

Figure 10-6. Alternator and Drive Hub

Typical for C-75, C-85, C-90, C-115, C-125, C-145, GO-300, GIO-300, O-300, IO-240, IOF-240

- | | | | | | | | |
|---|--------------------------|---|-----------------|---|----------|----|--------------|
| 1 | Alternator | 4 | Castellated Nut | 7 | Washer | 10 | Terminal Nut |
| 2 | Woodruff Key | 5 | Cotter Pin | 8 | Lock Nut | 11 | Washer |
| 3 | Drive Hub (single piece) | 6 | Gasket | 9 | Washer | 12 | Terminal Nut |

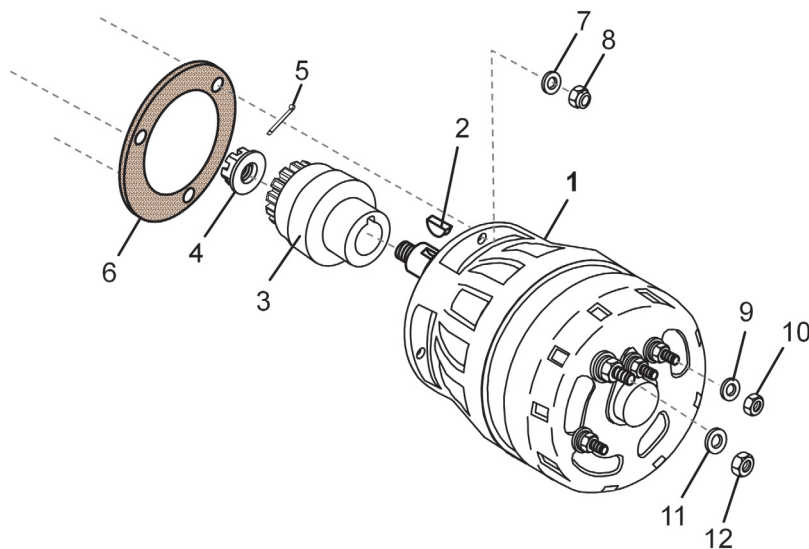

Figure 10-7. Alternator and Drive Hub

Typical for E-Series, 360 Series engines



10-4.2.2. Alternator Drive Hub Removal **AFT**

Applicable Engines:

C-75, C-85, C-90, C-115, C-125, C-145, E-165, E-185, E-225, GO-300, GIO-300, O-300, IO-240, IOF-240, and all IO-360, LTSIO-360, TSIO-360

1. Remove the alternator according to the instructions in Section 10-4.2.1.
2. Remove the cotter pin (Figure 10-8 or Figure 10-9) (4) and castellated nut (3); discard the cotter pin (4).
3. Remove the drive hub assembly (1) from the alternator shaft; Inspect the Woodruff key (2), discard the Woodruff key if damaged or unserviceable.

10-4.2.3. Alternator Drive Hub Installation **AFT**

The alternator drive hub may be a one piece coupling, or an assembly of multiple parts.

Applicable Engines:

C-75, C-85, C-90, C-115, C-125, C-145, E-165, E-185, E-225, GO-300, GIO-300, O-300, IO-240, IOF-240, and all IO-360, LTSIO-360, TSIO-360

1. The Woodruff key (Figure 10-8 or Figure 10-9) (2) is factory installed on the shaft; replacement is not required unless the Woodruff key is damaged. Verify the Woodruff key is present and serviceable.
2. For the one piece coupling *only*: Perform an “Alternator Drive Hub Inspection” according to the instructions in Section 6-4.22.2.
3. Align the slot in the alternator drive hub (1) with the Woodruff key and install the hub on the shaft. For single piece drive hub proceed to step 5. For the multi-piece drive hub assembly, continue with the next step.
4. For multi-piece drive hub assembly *only*:
 - a. Inspect the retainer (7) for physical damage; replace as required. Install the retainer (7) on the shaft with the bushing tray facing away from the alternator.
 - b. Install the sleeve (6) on the alternator shaft.
 - c. Inspect the bushings (8) for physical damage, cracks, chips, or erosion. Replace on condition. Install serviceable, or new, bushings (8) in the tray of the retainer.
 - d. Install the gear (5) on the shaft and align the drive lugs with the recess between the bushings.
5. Install the castellated nut (3) on the threaded end of the alternator shaft to secure the assembly.
6. Place the toothed portion of the drive hub gear in shielded vise jaws and tighten vise just enough to prevent rotation during the torquing of the nut (3).
7. Using a currently calibrated torque wrench, torque the castellated nut (3) to the minimum torque according to Appendix B specifications. If the slots in the nut do not align with hole in the shaft, gradually increase torque to a maximum of 200 in. lbs. to align the castellated nut (3) with the cotter pin hole. If alignment cannot be achieved within the torque limits, replace the castellated nut (3).



8. Install a new cotter pin (4) through the nut and alternator shaft according to the instructions in Appendix C-7. Cut and bend the cotter pin according to the instructions in Figure 10-4 to avoid interference with mating surfaces when installing the alternator on the engine.

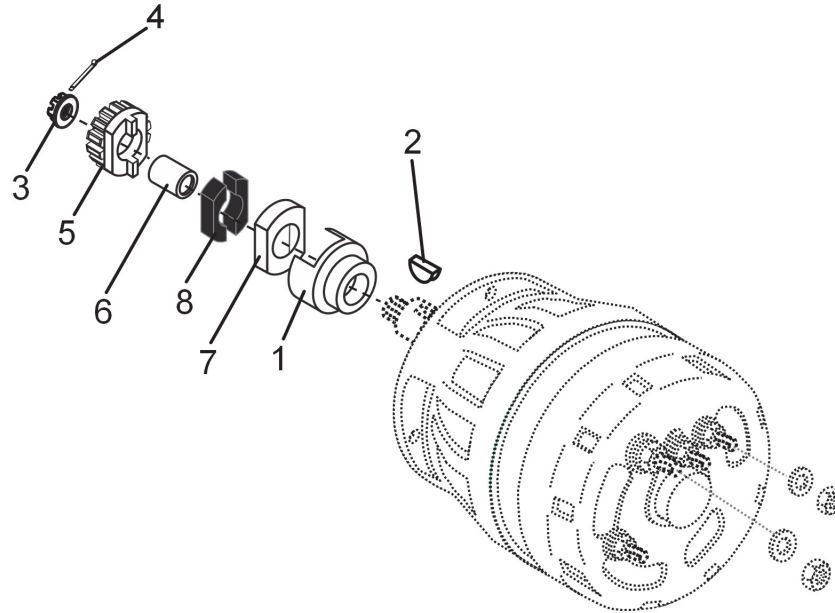

Figure 10-8. Multi-Part Alternator Drive Hub

- | | | | | | | | |
|---|--------------|---|-----------------|---|--------|---|----------|
| 1 | Drive Hub | 3 | Castellated Nut | 5 | Gear | 7 | Retainer |
| 2 | Woodruff Key | 4 | Cotter Pin | 6 | Sleeve | 8 | Bushings |

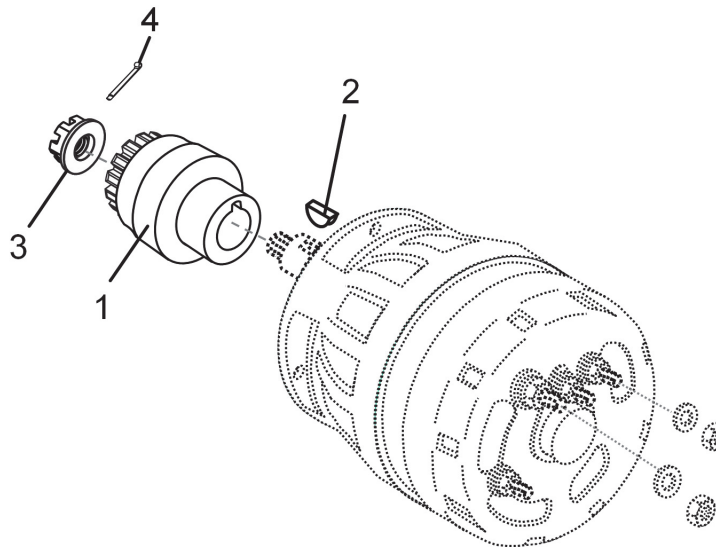

Figure 10-9. One Piece Alternator Drive Hub



10-4.2.4. Gear Driven Alternator Installation **AFT**

Applicable Engines:

C-75, C-85, C-90, C-115, C-125, C-145, E-165, E-185, E-225, GO-300, GIO-300, O-300, IO-240, IOF-240, and all IO-360, LTSIO-360, TSIO-360

WARNING

Turn the Ignition Switch OFF and disconnect engine electrical power before commencing maintenance or inspections. Confirm continuity between the magneto capacitor and aircraft ground to prevent accidental engine start during maintenance. Do not stand or place equipment within the arc of the propeller.

1. Turn the Ignition Switch to the OFF position and disconnect engine electrical power.
2. Perform a “Gear Tooth Inspection” on the camshaft gear according to the instruction in Section 11-1.1. If the camshaft gear teeth are chipped, broken, or damaged, disassemble the engine and replace the camshaft gear.
3. If the drive hub assembly was removed, install the drive hub assembly according to instructions in Section 10-4.2.3.
4. Install the new gasket (Figure 10-6 or Figure 10-7) (6) on the accessory case studs.
5. Install the alternator (1) on accessory case studs.

WARNING

Forceful alternator installation can cause mount lug fracture. If interference exists, inspect the mounting studs for bending; replace bent studs.

6. Verify the alternator enters the crankcase without binding and the mounting flange is properly seated against the crankcase. Do not force the alternator into position. If there is stud interference with the mounting lug holes while mounting the alternator, do not force the alternator over the studs.
7. Verify the alternator pilot enters the accessory case pilot bore squarely. Do not force the alternator pilot to fit into the pilot bore.
8. Secure the alternator with washers (7) and new lock nuts (8); torque the lock nuts according to Appendix B specifications.
9. For C-Series, O-200, IO-240 and IOF-240 engines only, install the tachometer drive adapter or tachometer drive adapter pad cover according to instructions in the primary ICA (**Ref: Section 1-1.1**).
10. Connect the alternator wiring according to the aircraft manufacturer’s instructions. If the alternator had a grounding strap when it was removed, install the grounding strap when installing the alternator.
11. Start the engine (“Engine Start” instructions in Section 7-3.2) and test the alternator output according to the instructions in the Aircraft Maintenance Manual.



10-4.3. Alternator Service Instructions

Continental Motors (CM) alternators listed in Table 10-5 are manufactured for CM by Hartzell Engine Technologies LLC. CM provides removal and installation instructions in the maintenance and overhaul manuals (identified in Section 1-1.1) for the alternators listed in Table 10-5. For detailed maintenance instructions for these alternators, refer to Hartzell Engine Technologies Part No. OE-A2 Maintenance and Overhaul Manual, Revision 4 or later, utilizing the instructions applicable to the alternator part numbers indicated in the second column of Table 10-5:

In lieu of using the alternator manufacturer's Instructions for Continued Airworthiness (ICA), the subject alternator may be removed and replaced with an airworthy alternator in accordance with applicable CM engine ICAs.

The OE-A2 Maintenance and Overhaul Manual is available from:

Hartzell Engine Technologies
2900 Selma Highway
Montgomery, AL 36108
1-888-461-6077 within the Continental U.S.
1-334-386-5400 International
www.hartzellenginetech.com

For CM alternators, Part Nos. 646843, 646845, 649304, or 649305, refer to the latest revision of CM Alternator Service Support Manual, X30531. For CM alternator Part No. 657377, refer to the M-2 Maintenance and Overhaul Manual.



Table 10-5. Alternator Cross Reference

Continental Motors Part Number	Hartzell Part Number referenced in OE-A2	Alternator Characteristics (Operating Voltage, Output Amperage, Drive Interface)
633661	ES4001	15V/60A Gear Driven
633962	ES4004	28V/38A Gear Driven
634442	ES4006	28V/60A Gear Driven
641668	ALT-9522	24V/50A Gear Driven
641670	ALX-9524	12V/70A Gear Driven
643008	ALX-9525B	12V/70A Gear Driven
649281	ES4002	12V/80A Gear Driven
649292	ES4017	28V/70A Belt Driven
649283	ES4009	28V/70A Belt Driven
652485	ALX-8523	12V/70A Belt Driven
652486	ALT-8520	24V/50A Belt Driven
653344	ES4029	28V/75A Gear Driven
654200	ES4024LP	28V/85A Belt Driven
655997	ES6012-6	12V/60A Belt Driven
656802	ES10024	24V/100A Gear Driven
656955	ES4024LP-2	28V/85A Belt Driven
657199	ES7024-14	24V/70A Belt Driven
658257	ES4024LP-3	28V/85A Belt Driven



10-5. Magneto Replacement

10-5.1. Continental Motors Magneto Removal

WARNING

Turn the Ignition Switch OFF and disconnect engine electrical power before commencing maintenance or inspections. Confirm continuity between the magneto capacitor and aircraft ground to prevent accidental engine start during maintenance. Do not stand or place equipment within the arc of the propeller.

1. Turn the Ignition Switch to the OFF position and disconnect engine electrical power.
2. Disconnect the Magneto Sensor (Figure 10-10) (2), if equipped, from the bottom of the magneto.
3. Remove the nut (8) and lock washer (9) and disconnect the airframe wiring from the magneto ground terminal according to the aircraft manufacturer's instructions.
4. Remove four screws (25) from the cable outlet plate (part of item 3 connected to ignition wires). Remove and discard the gasket (10).

CAUTION: Remove the magneto carefully to avoid dropping the bushings or retainers into the crankcase.

NOTE: Magnetos with dog ear mounts, such as those used on the C-75, C85, C90, O-200, and IO-240 engine models do not use magneto retainers (7).

5. Remove nuts (5), lock washers (6), and magneto retainers (7) from either side of magneto.

NOTE: The gasket (24) is only required on pressurized magnetos

6. Remove and discard gasket (24).

NOTE: If replacing the magneto, retain the pressurization fittings for the replacement magneto. pressurization fittings are not part of the magneto.

7. *On pressurized magnetos only*, remove clamp (16) and disconnect hose (16) at 90° fitting (19) from magneto.
8. Refer to the Ignition System Master Service Manual (X40000) for magneto maintenance instructions.
9. Perform an "Ignition System Inspection" according to instructions in Section 6-4.15.



10-5.2. Continental Motors Magneto Installation

WARNING

Turn the Ignition Switch OFF and disconnect engine electrical power before commencing maintenance or inspections. Confirm continuity between the magneto capacitor and aircraft ground to prevent accidental engine start during maintenance. Do not stand or place equipment within the arc of the propeller.

1. Turn the Ignition Switch to the OFF position and disconnect engine electrical power.
2. Complete the “Crankshaft Top Dead Center Alignment” in Section 6-4.9.1.1.
3. Verify the magneto drive coupling bushings and retainer are properly installed.
4. Perform steps 2-3 of the “Magneto to Engine Timing” in Section 6-4.9.1.2.

NOTE: Figure 10-10 depicts a pressurized magneto; instructions are the same for non-pressurized systems, except as noted.

5. Remove the pressurization fitting (Figure 10-10) (19) (plug, if non-pressurized magneto) from the magneto(s). Turn the impulse coupling backward until the marked distributor gear tooth is centered in the window.
6. Without turning the magneto coupling, hold the magneto in the position it will occupy when installed.
 - a. Align the gear coupling slot and impulse coupling lugs by pulling the magneto gear out and turning it to the desired position.
 - b. Push the gear back into the meshed position.
7. Install the new gaskets (24) on the magneto flange.

NOTE: Magnetos with dog ear mounts, such as those used on the C-75, C85, C90, O-200, and IO-240 engine models do not use magneto retainers (7).

8. Carefully insert the magneto in the crankcase/accessory case, aligning the drive coupling lugs mate with the drive bushing slot. Install four holding washers (7), lock washers (6) and nuts (5); hand-tighten the nuts at this time.
9. If the removed magneto is fitted with a magneto tachometer sensor (2), install the sensor in the magneto housing and torque the tachometer sensor to Appendix B specifications.
10. *On pressurized magnetos only*, apply CM Part No. 649366 to the male threads of the magneto pressurization fitting (19) and install the pressurization fitting (19) removed for inspection. Torque the pressurization fitting to Appendix B specifications.
11. Complete “Magneto to Engine Timing” in Section 6-4.9.1.2.
12. Disconnect the timing light from magnetos. Attach the airframe wiring harness to the magneto ground terminal according the aircraft manufacturer’s instructions.



NOTE: Unpressurized magnetos do not require a gasket between the magneto and the cable outlet plate.

13. Install the spark plugs and ignition harness according to instructions “Ignition System Maintenance” in Section 6-4.9.
14. Start the engine according to the “Engine Start” instructions in Section 7-3.2 instructions and perform a “Magneto RPM Drop Check” according to the instructions in Section 6-4.7.5.

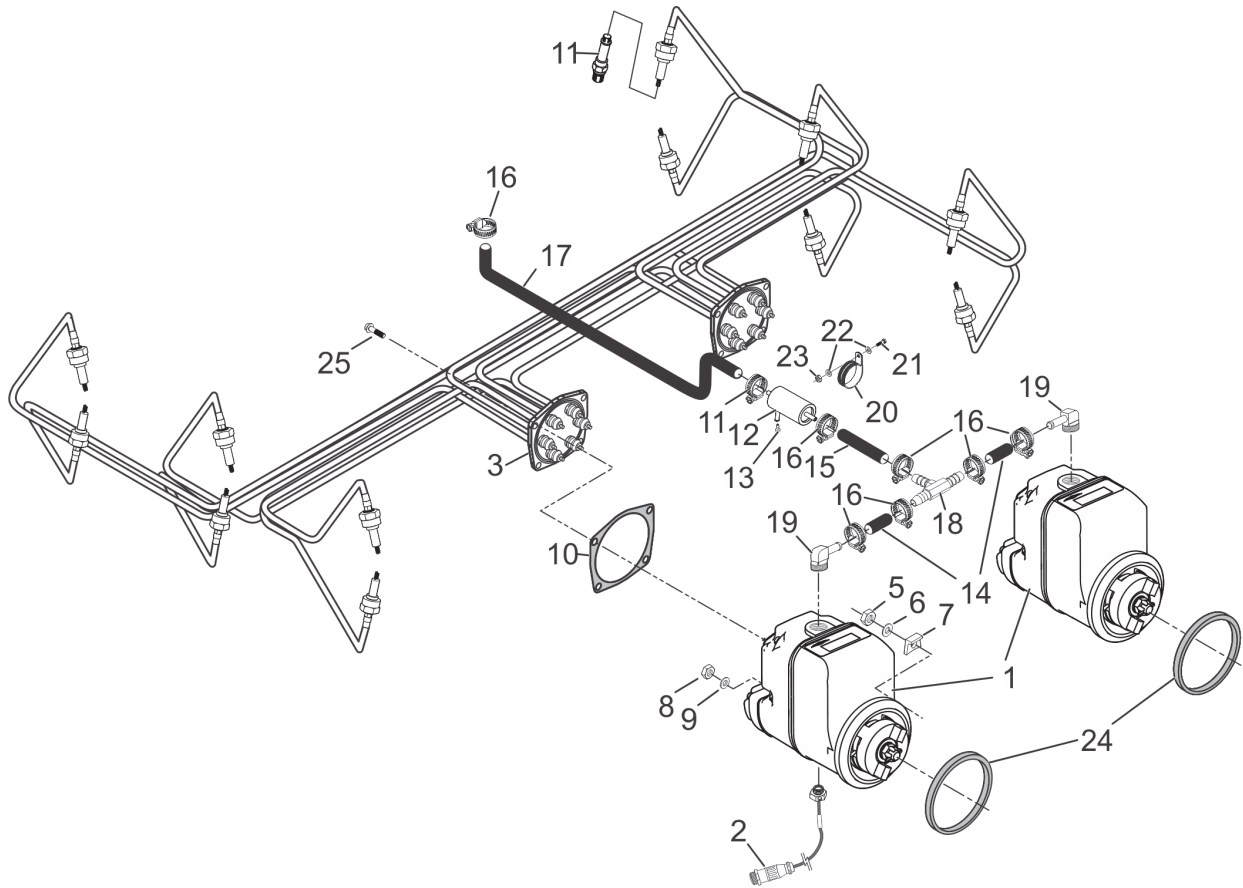

Figure 10-10. Continental Motors Ignition System

Typical Pressurized Six Cylinder Ignition System

1	Magneto	8	Nut	15	Hose	22	Washer, Flat
2	Magneto Sensor	9	Lock Washer	16	Clamp	23	Nut, Self Locking
3	Ignition Harness	10	Gasket	17	Hose	24	Gasket
4	Kit, Ignition System	11	Spark Plug	18	Tee	25	Screw Assembly
5	Nut	12	Filter Assembly	19	Fitting, 90° Elbow		
6	Lock Washer	13	Reducer -Drain Fitting	20	Clamp		
7	Retainer, Magneto	14	Hose	21	Bolt		



10-5.3. Champion (Slick) Magneto Removal

WARNING

Turn the Ignition Switch OFF and disconnect engine electrical power prior to commencing maintenance. Do not stand or place equipment within the rotational arc of the propeller.

1. Turn the Ignition Switch to the OFF position and disconnect engine electrical power.
2. Disconnect the airframe wiring from the magneto ground terminal according to the aircraft manufacturer's instructions.

NOTE: Figure 10-11 depicts a pressurized magneto; instructions are the same for non-pressurized systems, except as noted.

3. Remove the screws (Figure 10-11) (part of item 3 connected to ignition wires) from the ignition harness cap and separate the ignition harness cap from the magneto.

NOTE: If replacing the magneto, retain the pressurization fittings for the replacement magneto. pressurization fittings are not part of the magneto.

4. *On pressurized magnetos only*, remove clamp (11) and disconnect hose (10) at 90° fitting (15) from magneto.
5. Disconnect magneto sensor (23), if equipped, from the bottom of the magneto. Inspect the magneto sensor for cracks or physical damage; verify the vent hole open and free of obstructions; replace on condition.

CAUTION: Remove the magneto carefully to avoid dropping the bushings or retainers into the crankcase.

NOTE: Magnetos with dog ear mounts, such as those used on the C-75, C85, C90, O-200, and IO-240 engine models do not use magneto retainers (6).

6. Remove nuts (4), lock washers (5), and magneto retainers (6) from either side of magneto. Carefully remove the magneto from the crankcase, disengaging the drive coupling lugs from the drive bushing slot.
7. Remove and discard gasket (3).
8. Perform an "Ignition System Inspection" according to instructions in Section 6-4.15.
9. Replace the magneto with a new, rebuilt, or serviceable unit.



10-5.4. Champion (Slick) Magneto Installation

WARNING

Turn the Ignition Switch OFF and disconnect engine electrical power before commencing maintenance or inspections. Confirm continuity between the magneto capacitor and aircraft ground to prevent accidental engine start during maintenance. Do not stand or place equipment within the arc of the propeller.

1. Turn the Ignition Switch to the OFF position and disconnect engine electrical power.
2. Complete the “Crankshaft Top Dead Center Alignment” in Section 6-4.9.1.1.
3. Perform steps 2-3 of the “Magneto to Engine Timing” in Section 6-4.9.1.2.
4. Insert T118 timing pin in “L” or “R” hole (depending on magneto rotation) in the distributor block. Turn rotor in the opposite direction of rotation until the pin engages the gear.
5. Without turning the magneto coupling, hold the magneto in the position it will occupy when installed.
 - a. Align the gear coupling slot and impulse coupling lugs by pulling the magneto gear out and turning it to the desired position.

CAUTION: Remove the T118 timing pin before rotating the crankshaft to prevent magneto damage.

- b. Push the gear back into the meshed position and remove the T118 timing pin from the magneto.
6. Verify the magneto drive coupling bushings and retainers are serviceable and properly installed. Install new gaskets (Figure 10-11) (3) on the magneto flange. ■

NOTE: Magnetos with dog ear mounts, such as those used on the C-75, C85, C90, O-200, and IO-240 engine models do not use magneto retainers (6).
 7. Carefully insert the magneto in the crankcase/accessory case, aligning the drive coupling lugs with the drive bushing slot. Secure the magneto to the crankcase with retainers (6), lock washers (5) and nuts (4); hand-tighten the nuts at this time. Install the ventilation plug removed for inspection.
 8. Complete “Magneto to Engine Timing” in Section 6-4.9.1.2.
 9. Reconnect the tachometer sensor, if equipped, and torque to Appendix B specifications.
 10. *On pressurized magnetos only*, connect the pressurization hose (10) to the 90° fitting (15) and secure with hose clamp (11); torque the clamp (11) to Appendix B specifications.
 11. Disconnect timing light from magnetos. Attach the magneto ground wire according to the aircraft manufacturer’s instructions.



Non-Overhaul Repair and Replacement

12. Install the spark plugs and ignition harness according to instructions “Ignition System Maintenance” in Section 6-4.9.
13. Start the engine according to the “Engine Start” instructions in Section 7-3.2 instructions and perform a “Magneto RPM Drop Check” according to the instructions in Section 6-4.7.5.

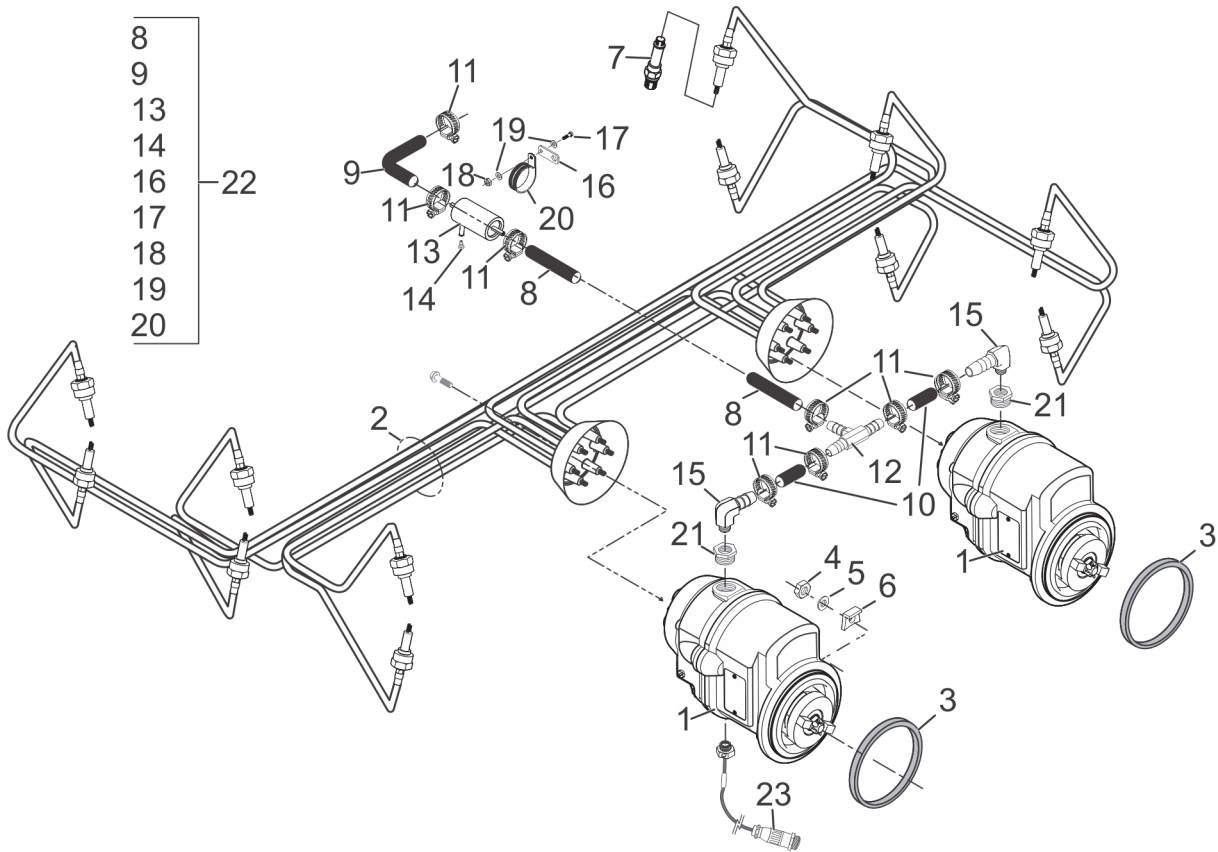

Figure 10-11. Champion (Slick) Ignition System
 Typical Pressurized Six Cylinder Ignition System

1	Magneto	7	Spark Plug	13	Filter Assembly	19	Washer
2	Gasket	8	Hose	14	Drain	20	Clamp
3	Ignition Harness	9	Hose	15	Elbow	21	Vent Bushing
4	Nut	10	Hose	16	Hose Bracket	22	Filter Kit
5	Lock Washer	11	Clamp	17	Bolt	23	Tachometer Sensor
6	Retainer, Magneto	12	Tee	18	Nut-Self Locking		



10-5.5. Magneto Filter Replacement

Pressurized magnetos incorporate a desiccant filter to trap moisture that could cause arcing at higher altitudes. Serviceable desiccant material in the filters is white in color; replace the filter when the desiccant material turns dark. If the filter requires replacement, inspect the internal magneto components for moisture and corrosion.

10-5.5.1. Continental Motors Magneto Filter Replacement

1. Inspect the magneto housing for cracks according to the appropriate Magneto Service Instructions (Section 1-2.5, “Related Publications”). Inspect the magneto internal parts for evidence of moisture or corrosion according to the Magneto Service Instructions.
2. Remove magneto filter and hoses:
 - a. Loosen hose clamps (Figure 10-12) (4) and remove the filter (6), plug (7), hoses (1, 2 & 3) and clamps (4).
 - b. Discard the filter (6), plug (7) and hoses (1, 2 & 3).

NOTE: For continued service, replace hoses and clamps on condition; replace the filter assembly and hoses at overhaul. Where complete filter assembly replacement instructions are provided, perform applicable steps required to return the ignition system to service.

3. Install new magneto filter and hoses:
 - a. Install new hoses (3) between the tee (5) and the elbow fittings (8); secure the hoses (3) with clamps (4). Tighten but do not torque clamps.
 - b. Connect a new hose (2) on the open side of the tee (5) and secure with a clamp (4). Tighten but do not torque clamps.
 - c. Connect a new hose (1) to the upper deck reference pressure fitting on the intake manifold and secure with a clamp (4). Tighten but do not torque clamps.
 - d. Remove the shipping plugs and inspect the new filter (6) for cracks. Verify the reducer/drain plug (7) is installed in the filter (6) drain hole.
 - e. If a clamp is used to secure the filter assembly to the engine:
 - 1) Loosen the screw (9) and locknut (10) securing the cushion clamp (12).
 - 2) Insert the new filter assembly (6) in the cushion clamp (12) with the arrow pointing toward the magnetos and the drain tube pointing downward.
 - 3) Secure the cushion clamp (12) with a screw (9), washers (11) and new lock nut (10); tighten the fasteners (9 & 10) to Appendix B specifications.
 - f. Loosen two clamps and place them on the open ends of hoses (1 & 2). Connect the new filter assembly (6) to the hoses (1 & 2) with the arrow on the filter toward the magnetos and the drain pointing down.
 - g. Adjust hoses (1, 2 & 3) to minimize twisting stress and torque clamps (4) to Appendix B specifications.



Non-Overhaul Repair and Replacement

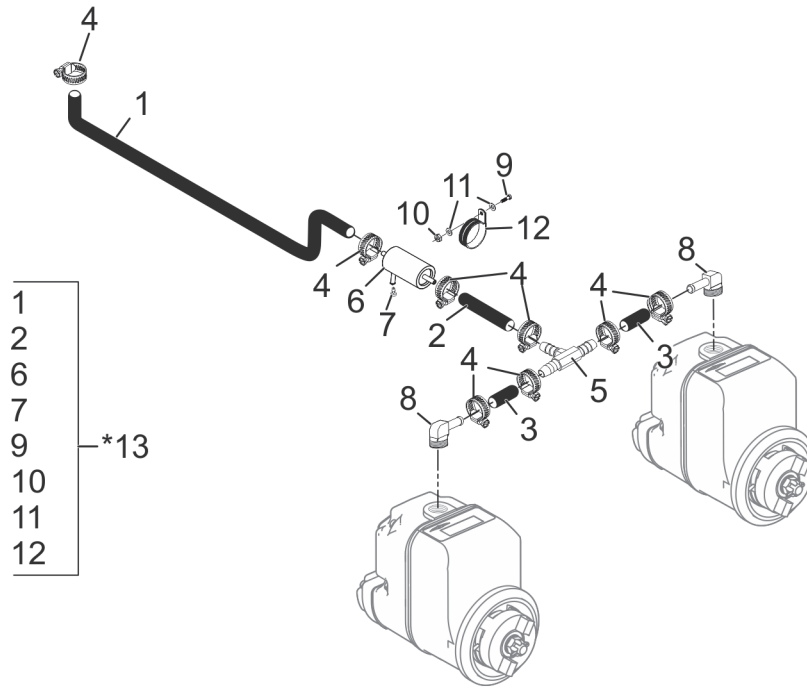

* Various configurations may include optional filter kit.

Figure 10-12. Continental Motors Pressurized Magneto Filter (Typical)

1	Hose	5	Tee	9	Bolt	13	* Filter Kit
2	Hose	6	Filter Assembly	10	Nut, Self-Locking		
3	Hose	7	Drain	11	Washer		
4	Clamp	8	Elbow	12	Clamp		



10-5.5.2. Champion (Slick) Magneto Filter Replacement

1. Inspect the magneto housing for cracks according to the appropriate Magneto Service Instructions (Section 1-2.5, “Related Publications”). Inspect the magneto internal parts for evidence of moisture or corrosion according to the Magneto Service Instructions.
2. Remove magneto filter and hoses:
 - a. Loosen hose clamps (Figure 10-13) (4) from the hoses (1 & 2) at each end of the filter (6); remove the filter (6) from assembly hoses (1 & 2) and clamps (4)
 - b. Inspect the hoses (1, 2 & 3) and fittings (5 & 8) for security and serviceability. Replace cracked or brittle hoses.

NOTE: For continued service, replace hoses and clamps on condition; replace the filter assembly and hoses at overhaul. Where complete filter assembly replacement instructions are provided, perform applicable steps required to return the ignition system to service.

3. Install new magneto filter and hoses:
 - c. Remove the shipping plugs and inspect the new filter assembly (6) for cracks. Verify the reducer/drain plug (7) is installed in the filter drain hole.
 - a. Connect new hoses (3) to the tee (5) fitting 180° apart and secure with hose clamps (4). Connect the open ends of the hoses (3) to the 90° fittings (8) and secure with clamps (4). Connect a new hose (1) to the remaining fitting on the tee (5) and secure with a clamp (4).
 - b. Connect the short end of a 90° hose (2) to the upper deck reference pressure fitting on the intake manifold and secure with a clamp (4).
 - c. Insert the new filter assembly (6) in the cushion clamp (13) with the arrow pointing toward the magnetos and the drain tube pointing downward. Secure the cushion clamp (13) to the bracket (9) with a screw (10), washers (12) and new lock nut (11); tighten the fasteners (10 & 11) to Appendix B specifications.
 - d. Connect the hoses (1 & 2) to the new filter; secure the hoses (1 & 2) to the filter with clamps (4).
 - e. Adjust hoses (1, 2 & 3) to minimize twisting stress and torque clamps (4) to Appendix B specifications.



Non-Overhaul Repair and Replacement

NOTE: Magneto orientation will vary depending on engine application.

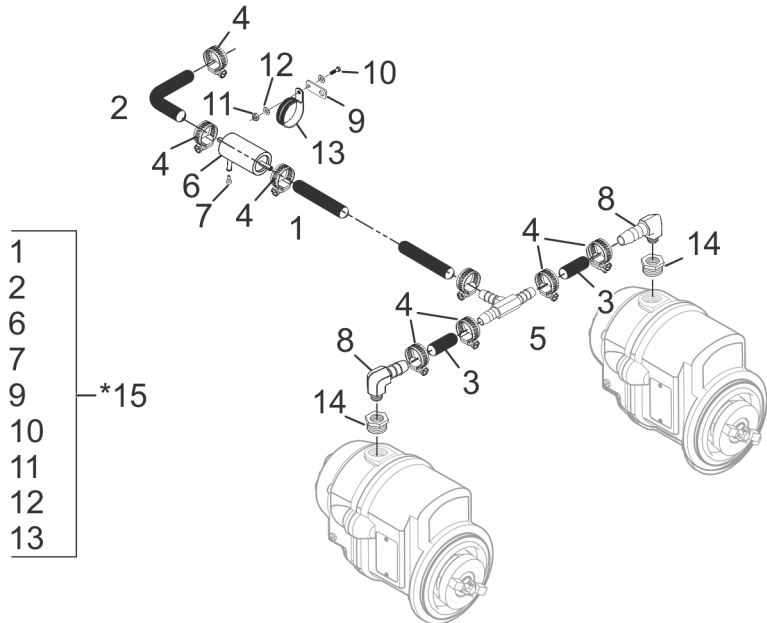

* Various configurations may include optional filter kit.

Figure 10-13. Champion (Slick) Pressurized Magneto Filter (Typical)

1	Hose	5	Tee	9	Hose Bracket	13	Clamp
2	Hose	6	Filter Assembly	10	Bolt	14	Vent Bushing
3	Hose	7	Drain	11	Nut-Self Locking	15	Filter Kit
4	Clamp	8	Elbow	12	Washer		



10-6. Cylinder Repairs

1. Remove suspect cylinders according to the instructions in the primary engine instructions for continued airworthiness (ICA).
2. Perform the “Cylinder Inspections” in Section 6-4.11. After inspection, refer to the “Cylinder Repair vs. Replacement Guidelines” in Table 10-6 to determine if the cylinder can be repaired or if replacement is required.
3. Refer to “100% Parts Replacement Requirements” and “Mandatory Replacement Parts” in Appendix C-2 to determine the replacement items for either in service repair or overhaul.

Table 10-6. Cylinder Repair vs. Replacement Guidelines

Condition	Corrective Action
Cylinder with radial fin crack extending to the root of a fin	Replace ¹ the cylinder
Broken, bent (or straightened), or pitted cylinder head or barrel fins ²	Replace ¹ the cylinder
Power stroke stress on cylinder barrel; heavy rust or pitting, indentation; chafing or cracks on cylinder barrel	Replace ¹ the cylinder
Cracks in cylinder head structure	Replace ¹ the cylinder
Cracked or eroded valve seat bore	Replace ¹ the cylinder
Static seal leakage or leakage from head to barrel seal or crack in head or barrel	Replace ¹ the cylinder
Discolored/burned paint, Piston pin scoring or damage to the cylinder bore (usually due to overheating)	Replace ¹ the cylinder Do Not Repair ³
Blistered paint on the cylinder barrel	Replace ¹ the cylinder
Cylinder head-to-barrel junction movement	Replace ¹ the cylinder
Low differential pressure coupled with excessive oil consumption	Repair or replace ⁴ the cylinder
Scratches in the honed surface of the cylinder wall or cylinder bore	Repair the cylinder
Pitting, sharp dents or chafing in fin tips less than 0.050 inches (1.3 mm) deep	Repair the cylinder

1. Replacement cylinders are available in several configurations, starting with a basic assembly and progressing to cylinders with more components installed:
 - Cylinder and Valve Assembly (includes the Basic Cylinder Assembly plus valve components).
 - Loaded Cylinder and Valve Assembly (Cylinder and Valve Assembly plus rocker shaft, piston, piston rings, and gasket set).
 - Cylinders for most engine models are available in standard honed steel, through hardened, or nickel silicon carbide plated
 - Consult Continental Motors’ web site for the latest parts information.
2. Bent barrel fins may remain in service if fin is not bent more than one-half the distance to the next fin. If cylinder head or barrel fins are bent more than half the distance to the next fin, replace the cylinder.
3. Do not attempt to remove overheating damage by grinding the cylinder bore to the next allowable oversize. Cylinder barrel overheating destroys material strength.
4. If the cylinder is otherwise acceptable on inspection and the fits and clearances provide enough tolerance that the cylinder can be ground and honed or plated, repair the cylinder; otherwise replace the cylinder.



10-6.1. Cylinder Replacement

10-6.1.1. Cylinder Removal

WARNING

Turn the Ignition Switch OFF, disconnect the battery from the engine and confirm continuity between the magneto capacitor and aircraft ground before commencing maintenance to avoid uncommanded engine starts during maintenance. Do not stand or place equipment within the arc of the propeller.

If one or more cylinders require removal for in-service inspection, replacement or repair, use the following guidelines:

1. Remove the aircraft cowling and baffles according to the aircraft maintenance manual.
2. Disconnect the spark plugs and ignition harness from the subject cylinder(s) according to the instructions in the primary ICA (**Ref: Section 1-1.1**).
3. Remove the induction tubes and exhaust system from the subject cylinder(s) according to the instructions in the primary ICA.
4. Disconnect the fuel injection lines from the subject cylinder(s) according to the instructions in the primary ICA.
5. Disconnect cylinder drains, if equipped, according to primary ICA instructions.
6. If installed, disconnect the CHT sensors (probes) from the subject cylinder(s) according to the instructions in the primary ICA.
7. During engine cylinder component removal, inspect components for wear and conformance to dimensional criteria. Replace components based on the following:
 - a. Only parts that meet *service limits* may remain in service or be re-used.
 - b. If a part fails to meet a service limit tolerance, replace it with a part that meets the specified service limits.
8. Remove the valve train from the affected cylinders according to the instructions in the primary ICA.
9. Using the appropriate wrenches, carefully remove the flange nuts from the cylinder base flange.
10. As the last pieces of fastening hardware are removed, cradle the cylinder in your arm for support.

CAUTION: The piston will be damaged if allowed to drop as the cylinder is withdrawn.
11. While supporting the cylinder, carefully pull the cylinder outward in a straight plane with one hand, keeping the other hand free to catch the piston as the cylinder is withdrawn to prevent damage to the crankcase or cylinder.



12. Remove the cylinder o-ring (or packing). Wrap the old cylinder base o-ring (or packing) in a figure 8 pattern (Figure 10-14) around four of the crankcase studs and stretch the two vertical segments of the packing over the connecting rod to secure it.

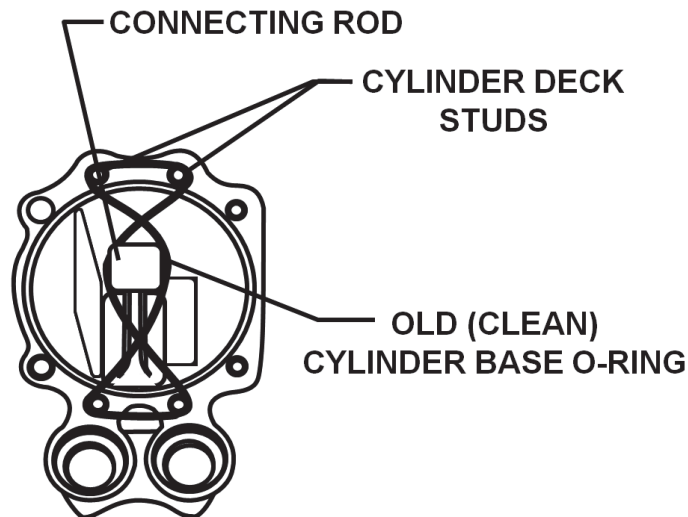

Figure 10-14. Cylinder Base O-Ring supporting Connecting Rods

CAUTION: Piston ring reinstallation is not recommended. If the piston rings are removed for any reason, discard the removed piston rings and install a new set of piston rings, with end gaps adjusted for the destination cylinder.

13. Remove the piston pin and piston from the connecting rod. Inspect the piston and piston pin according to the instructions in the primary ICA. If piston ring removal is required, discard the piston rings and obtain, gap and install a new set of piston rings according to the instructions in the primary ICA.
14. Before commencing any cylinder repairs, perform a static leak check on the cylinder:

CAUTION: Do not allow the fiber drift to contact the valve spring retainer or rotocoil.

 - a. Place a fiber drift on the rocker arm directly over the valve stem.
 - b. Tap the drift several times with a hammer to dislodge any debris that may be between the valve face and seat.
 - c. Invert the removed cylinder with the spark plug installed.
 - d. Fill the inverted cylinder bore with nonflammable solvent.
15. Look for leaks in the cylinder head to barrel junction. If the cylinder head and barrel seal is leaking, discard the cylinder. If the intake or exhaust seat seals or the spark plug seals are leaking, note the discrepancy and repair according to the instructions in the primary ICA.
16. Disassemble, clean, inspect, and make appropriate repairs to return the cylinder to the published service limits according to the instructions in the primary ICA.



10-6.1.2. Cylinder Installation

Replace worn or out of tolerance components based on the following criteria:

- Only allow parts that meet the *service limits* may remain in service.
- If a part has reached a service limit tolerance, it must be replaced with a part that conforms to the specified new part tolerances or service limits.
- Clean cylinders and pistons according to the instructions in the primary ICA.
- Perform fluorescent penetrant, magnetic particle inspections according to instructions in Section 11-2 and dimensional inspections on specified cylinder and piston parts according to instructions in the primary ICA.
- Install serviceable lifters in the same location from which they were removed.
- Assemble cylinders which meet the inspection criteria and service limits according to the instructions in the primary ICA with serviceable pistons and new piston rings.

WARNING

Do not apply any form of sealant to the crankcase cylinder deck, chamfer, cylinder mounting flange, cylinder base O-ring, or cylinder fastener threads. The use of RTV silicone, Gasket Maker or any or other sealant on the areas listed above during engine assembly will cause a loss of cylinder deck stud or through-bolt torque. Subsequent loss of cylinder attachment load, loss of main bearing crush or fretting of the crankcase parting surfaces will occur. The result will be cylinder separation, main bearing movement, or oil starvation and catastrophic engine failure. USE ONLY CLEAN 50 WEIGHT AVIATION ENGINE OIL ON SURFACES LISTED.

1. Inspect a new cylinder base o-ring (or packing) for cracks or deformities. If serviceable, lubricate the new cylinder base o-ring (9) with clean 50-weight aviation engine oil.
2. Install the new cylinder base O-ring (or packing), lubricated with clean 50-weight aviation engine oil on the cylinder base flange; verify the O-ring is not twisted on the cylinder base flange after installation.
3. Lubricate cylinder through bolt and deck stud threads using clean 50 weight aviation engine oil.
4. Install a serviceable piston, fitted with new piston rings, and piston pin partially in the cylinder bore.
5. Carefully rotate the crankshaft, placing the connecting rod of the cylinder being installed in the outermost position. Remove the packing that was installed for connecting rod support.
6. Line the piston up with the connecting rod and slide the piston pin into the connecting rod.
7. Using a ring compressor, compress the piston rings and push the cylinder until the fourth piston ring is positioned inside the cylinder barrel.



8. Remove the ring compressor and push the cylinder assembly against the crankcase cylinder deck with the stud holes aligned.
9. While supporting the cylinder, install, but do not torque, the cylinder flange nuts.
10. For cylinder replacement, torque the cylinder fastening hardware according to the “Cylinder Torque” instructions in Section 10-6.1.3.
11. Rotate the crankshaft through multiple revolutions to verify smooth rotation of the crankshaft. If rotation is not smooth or binding is evident, disassemble the engine to determine the cause. Verify crankshaft end play (end clearance) is within the tolerance specified in the primary ICA. If no end play is present, disassemble the engine to determine the cause.
12. Install the valve train and pushrods according to the instructions in the primary ICA.
13. Install cylinder baffles and baffle supports (if equipped), as required by the instructions in the primary ICA.
14. Connect cylinder drains, if equipped, according to primary ICA instructions.
15. Install fuel injectors and connect the fuel injection lines according to the instructions in the primary ICA.
16. Install the induction and exhaust system according to the primary ICA instructions.
CAUTION: Service the engine with SAE J1966 mineral oil for engine break-in.
17. Service the engine with mineral oil according to instructions in Section 6-4.8.
18. Perform a leak check on the fuel injection system according to the instructions in the primary ICA.
19. Install the spark plugs and ignition harness according to the instructions in the primary ICA.
20. Perform an initial engine run according to the instructions in the primary ICA.
21. Install the aircraft cowling and aircraft-supplied accessories according to the aircraft manufacturer’s instructions.
22. Perform an “Engine Operational Check” and adjust engine fuel system to meet engine model specifications according to the instructions in Section 6-4.7.
23. Perform a “Flight Check” according to the instructions in Section 7-2.4 prior to release to normal operation.
24. Follow the “Engine Break-In” instructions in Section 7-2.4.1 for the first 25 hours of operation.
25. Perform an “25-Hour Initial Operation Inspection” in Section 6-4.2 after the first 25 hours of engine operation. When oil consumption has stabilized, replace the mineral oil with ashless dispersant aviation engine oil according to Section 6-4.8.



10-6.1.3. Cylinder Torque

CAUTION: This cylinder torque procedure is for individual cylinder installation. For complete engine assembly and torque, refer to instructions in the primary ICA.

1. Lubricate the cylinder base stud threads, through bolt threads and nut threads **on BOTH sides** of the engine with clean, 50-weight aviation oil.

WARNING

Failure to torque through bolt nuts on both sides of the engine may result in a loss of main bearing crush, main bearing shift, crankshaft fracture, and engine failure.

2. Install and torque the through bolt nuts and cylinder base nuts to one half of the final torque value specified in Appendix B in the sequence shown in Figure 10-15.
3. Torque the through bolt nuts and cylinder base nuts to the full final torque value specified in Appendix B in the sequence shown in Figure 10-15. Torque the through bolt nuts on both sides of the engine (even if only one cylinder is being installed).

NOTE: Seventh studs are not used on all installations. For single cylinder torque, the seventh stud locations are torqued last at each cylinder location.

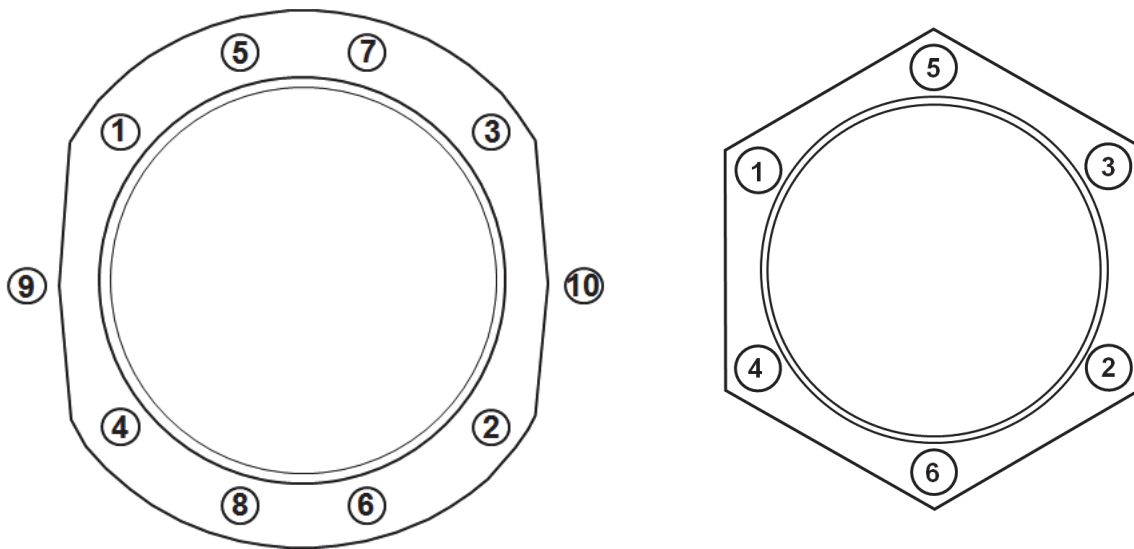

Eight Bolt Flange

Six Bolt Flange

Figure 10-15. Cylinder Torque Sequence



10-6.2. Cylinder Position Numbers

Original cylinders have a position number stamped on the edge of the base flange. New cylinders must have a position number stamped in the location shown in Figure 10-16.

WARNING

Do not stamp or etch the cylinder position on the piston. Pistons are not stamped with position numbers. To mark the piston with installed position, use a felt tip marker or attach a tag indicating the installed position.

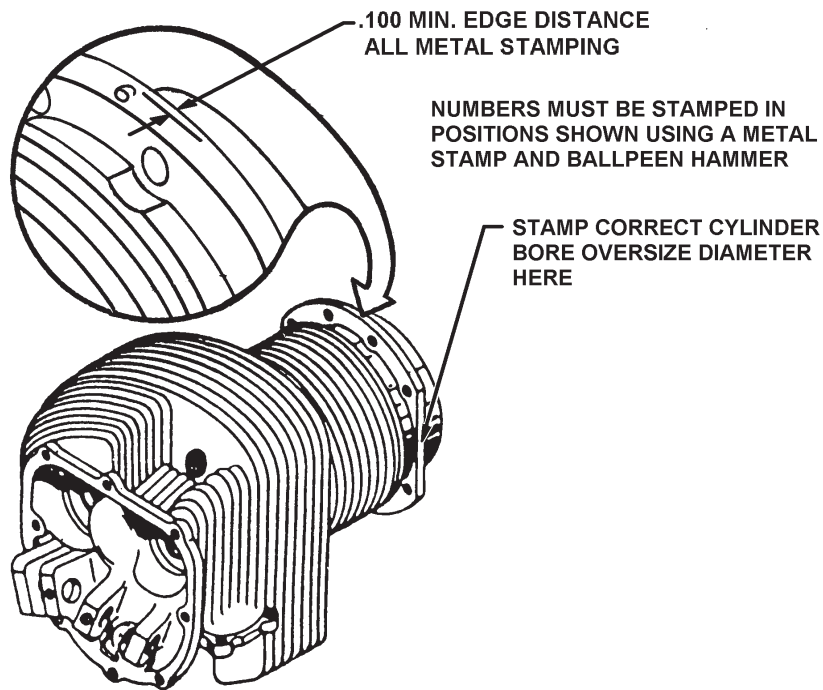

Figure 10-16. Cylinder Position Number Location

10-6.3. Cylinder Head Repair

WARNING

Do not perform any structural weld repairs on the cylinder head. Welding the cylinder head structure can destroy the assembly preloads and casting strength resulting in cylinder assembly failure.

Replace cracked or damaged cylinders. Do not attempt to repair a cracked cylinder head.



10-6.4. Cylinder Fin Tip Repair

CAUTION: Do not attempt to straighten bent cylinder fins.

Pitting, sharp indentations or chafing damage in the fin tip LESS than 0.050 inch deep may be blended with a fine grit disk or stone. Blend the area smooth so no sharp edges remain and ensure that original fin contours remain. Inspect the area for cracks and if no cracks are present, clean the surface thoroughly according to instructions in Chapter 12. Perform Magnetic Particle Inspection on the cylinder barrel or Fluorescent Penetrant Inspection on head, depending on area of repair.

10-6.5. Cylinder Barrel Repair

WARNING

Cylinder Barrel Repair requires FAA certification. If you are not certified, do not attempt to repair the cylinder barrel.

If the cylinder passes the visual inspection and static leak check at the cylinder head to barrel junction, the cylinder barrel may be ground to the next authorized oversize dimension by an FAA Part 145 Repair Stations certified to grind engine cylinders. These facilities grind and hone the cylinder bore using a cam-controlled grinder to grind the cylinder barrel to the next authorized oversize dimension specified in Section 10-6.9.

After grinding the cylinder barrel to the next authorized oversize dimensions, perform a Magnetic Particle Inspection on the cylinder bore and identify the cylinder with the correct bore size by steel-stamping the barrel flange with the appropriate oversize designation as depicted in Figure 10-16.

CAUTION: Replace the engine cylinder if the barrel fins exhibit pitting, sharp indentation, or chafing damage greater than 0.050 inch deep. Do NOT weld cylinder barrel fins or cylinder barrels (see Section 10-6.4, “Cylinder Fin Tip Repair”).

If a cylinder has been ground, the cylinder bore must be honed according to instructions in the primary ICA (**Ref: Section 1-1.1**).

CAUTION: Do not attempt to straighten bent cylinder barrel fins.

Bent cylinder barrel fins may continue in use provided the fin is not bent more than one-half the distance to the next barrel fin. Do not attempt to straighten cylinder barrel fins. If barrel fins are bent more than one-half the distance to the next fin, replace the cylinder.

10-6.6. Cylinder Stud Replacement

CAUTION: Rosan ring lock studs have been replaced by stainless steel studs on the Gold Standard cylinder configurations. Cylinders originally configured with Rosan studs are not candidates for retrofit to stainless steel exhaust studs.

Replace exhaust manifold studs, regardless of condition, at overhaul. Check the stud alignment using a tool maker's square. Replace studs that are bent, loose, or damaged according to the “Stud Replacement” instructions in Section C-6. Install the new studs to the specified heights listed in primary ICA (**Ref: Section 1-1.1**).



10-6.7. Spark Plug Heli-coil Replacement

Equipment Required

- Heli-coil Extracting Tool
- Heli-coil Installation Tool
- Heli-coil No. 520-2 Expansion Tool

1. Before attempting to remove a damaged heli-coil insert, use a sharp pointed tool to pry the teeth at the outer heli-coil end away from the cylinder head metal.
2. Tap the Extracting Tool into the insert until firmly seated; remove the heli-coil.
3. Using the proper size mandrel on the Installation Tool, place a new stainless steel heli-coil in the cutout side of the Installation Tool and engage the driving tang toward the threaded end.
4. Engage the tang with the slotted end of the driving mandrel and wind the insert into the thread sleeve, compressing the insert.
5. Hold the sleeve so the heli-coil can be seen through the slot in the threaded end.
6. Turn the mandrel crank until the insert starts into the cylinder. If the sleeve is not in contact with the head surface, grip the sleeve and mandrel and turn until the sleeve touches lightly.

WARNING

The heli-coil insert end must not protrude into the combustion chamber after it has been installed.

7. Wind the heli-coil into the cylinder head until its toothed end lies within the first full thread. The teeth should be in position to enter the depressions made by the original insert. If driven too far, the insert will emerge in the combustion chamber and will have to be wound through and removed.
8. When the heli-coil is in the correct position, use long-nose pliers to bend the driving tang back and forth across the hole until it breaks off at the notch.
9. Coat the threaded end of the No. 520-2 Expanding Tool with Alcoa® thread lube or a mixture of white lead and oil.
10. Screw the No. 520-2 Expanding Tool into the new insert until its final thread forces the teeth firmly into the cylinder head metal.



10-6.8. Cylinder Protective Coatings

1. Clean the exterior cylinder head surface.
2. Apply a protective coating of Alodine on the cylinder head exterior surface according to the manufacturer's instructions.
3. Thoroughly clean the entire cylinder with mineral spirits and air dry.
CAUTION: Do not paint the cylinder flange nut seats, skirt, or flange-to-crankcase mating surface.
4. Mask the cylinder flange nut seat contact surfaces, cylinder skirt and flange-to-crankcase mating surfaces.
CAUTION: Repeated application of paint to the cylinder head and barrel will act as an insulator and inhibit the cylinder's ability to dissipate heat.
5. Apply a protective coating of specified enamel paint or equivalent (Section 3, "Lubricants, Sealants, and Adhesives") to the cylinder according to instructions in the primary ICA.
6. After the paint dries completely, remove all masking materials.
7. Coat all bare steel surfaces with clean 50-weight aviation engine oil.
8. Store the cylinder assembly in a clean protected area until cylinder installation.



10-6.9. Cylinder Bore and Piston Fit Specifications

CAUTION: Dimensional limits and repair instructions in this Section do not apply to Nickel Silicon Carbide (NiC3) plated cylinders. Refer to SB15-6 for NiC3 cylinder airworthiness instructions.

Specifications in this document provided the following:

- Cylinder bore dimensions - New minimum/maximum, service limits (for continuing cylinders in service between major overhaul(s)) and oversize service limits.
- Piston to cylinder clearance specifications for coated or uncoated pistons.
- Piston ring gaps and designated location in cylinder to measure ring gaps.
- Piston diameters, piston skirt diameters, and pin to dome height dimensions.

For disassembly, inspection, repair and assembly instructions, consult the applicable engine Instructions for Continued Airworthiness (Section 1-1.1).

The Gold Standard project streamlined many of the unique cylinder dimensional characteristics established through generations of product improvements to a common design specification shared with all engine models sharing the same cylinder bore size. Engine serial numbers 1006000 (and subsequent) and engine cylinder assemblies with part number 658XXX (and later) conform to the Gold Standard design specifications. In-service engines with earlier cylinder assembly part numbers may continue to use the pre-Gold standard specifications, where applicable, until cylinder replacement.

The “**New Limits MIN & MAX**” dimensions for **D, X, and Y** diameters identify cylinder barrel machining characteristics of new and authorized oversize (AO) dimension cylinders.

Only the D and the X diameters are used to determine the serviceability of the cylinder barrel. No wear limit is given for Y diameter because it is used for machining reference only. For consistency, measure cylinder bore D and X dimensions in the plane through the spark plug holes; repeat at a right angle (90°) to the first measurement and then average the two results.

To determine out of round, measure first in the plane through the spark plug holes; repeat the measurement at a right angle (90°) to the first measurement and then subtract the smaller dimension from the larger. The difference must not exceed the out of round limit specified.

New or authorized oversize cylinder bore dimensions must be used at engine overhaul. Service limits may be used to return cylinders to service on engines that have not reached their published TBO. Do not return any cylinder to service that cannot be machined to conform to the dimensional limits specified in this manual.

Piston ring gaps and cylinder dimensions must be maintained within the specifications provided in this manual. If the cylinder is machined to the next larger AO size, piston rings of the same AO size must be installed in the machined cylinder.

Piston specifications are presented in tabular form, (Table 10-24). Column 2, non-coated pistons (with untreated skirt or graphite treated skirts pistons) were discontinued in 1998 and are provided for reference only.



Table 10-8. 5.250 Inch Cylinder Barrel Dimensions
Applicable to Pre-Gold Standard: IO346, TSIO550 (all except N), TSIOF550

Size	"D" Diameter (inches)			"X" Diameter (inches)			"Y" Diameter (inches)		
	Minimum	Maximum	Service Limit	Minimum	Maximum	Service Limit	Minimum	Maximum	Service Limit
STD.	5.252	5.254	5.257	5.248	5.251	5.258	5.245	5.248	N/A
.005	5.257	5.259	5.262	5.253	5.256	5.263	5.250	5.253	N/A
.010	5.262	5.264	5.267	5.258	5.261	5.268	5.255	5.258	N/A
.015	5.267	5.269	5.272	5.263	5.266	5.273	5.260	5.263	N/A

Cylinder bore out of round: new cylinder must not exceed 0.001" in barrel above flange; service limit must not exceed 0.003" at measured diameters.

Table 10-9. Piston to Cylinder Clearance
IO346, TSIO550, TSIOF550

5.250 Inch Piston	Piston in Cylinder (new)	
	Pre-Gold Standard	Post-Gold Standard
All Non-Coated	0.008 - 0.011 LOOSE	0.007 - 0.010 LOOSE
Manganese Phosphate Coated	0.009 - 0.012 LOOSE	0.008 - 0.011 LOOSE

Measure clearance perpendicular to piston pin bore at "D" diameter
 Measure **below 4th ring groove** perpendicular to piston pin bore.

Table 10-10. Piston to Cylinder Clearance
IO520, LIO520, GTSIO520, LTSIO520, TSIO520, IO550, IOF550

5.250 Inch Piston	Piston in Cylinder (new)
All Non-Coated	0.008 - 0.011 LOOSE
Manganese Phosphate Coated	

Measure clearance perpendicular to piston pin bore at "D" diameter
 Measure **below 4th ring groove** perpendicular to piston pin bore.

Table 10-11. Piston to Cylinder Clearance
TSIOL550

5.250 Inch Piston	Piston in Cylinder (new)
All Non-Coated	0.007 - 0.010 LOOSE
Manganese Phosphate Coated	0.008 - 0.011 LOOSE

Measure clearance perpendicular to piston pin bore at "D" diameter
 Measure **below 4th ring groove** perpendicular to piston pin bore.



Table 10-12. Ring Gap Specifications
5.250 Inch Cylinder - All IO346, IO520, GTSIO520, LIO520, LTSIO520, TSIO520, IO550, IOF550, TSIO550, TSIOF550, TSIO550

RING	Part Number	Gaps				
		5.250 Gage Diameter	Pre-Gold Standard ¹	Pre-Gold Standard Service	Post-Gold Standard	Post-Gold Standard Service
Ring Set	654716A1	N/A	N/A	N/A	N/A	N/A
Top Ring	648005	0.026 - 0.034	0.032 - 0.046	0.032 - 0.055	0.029 - 0.043	0.029 - 0.052
Second Ring	654719	0.032 - 0.040	0.038 - 0.052 ²	0.038 - 0.061 ²	0.035 - 0.049 ²	0.035 - 0.058 ²
Oil Control Ring	654717 ³	0.012 - 0.022	0.018 - 0.034	0.018 - 0.043	0.015 - 0.031	0.015 - 0.040
Fourth Ring / Skirt	648008	0.012 - 0.022	0.018 - 0.034	0.018 - 0.043	0.015 - 0.031	0.015 - 0.040

1. Applies to Pre-Gold Standard piston ring gaps on IO346, TSIO550-C, E, G, K, and TSIOF550-D, J, K, and P.
2. Gap for second ring is nominally 0.006" larger than the top ring.
3. Part No. 654717 consists of expander (Part No. 654718) and ring (Part No. 649250-1).

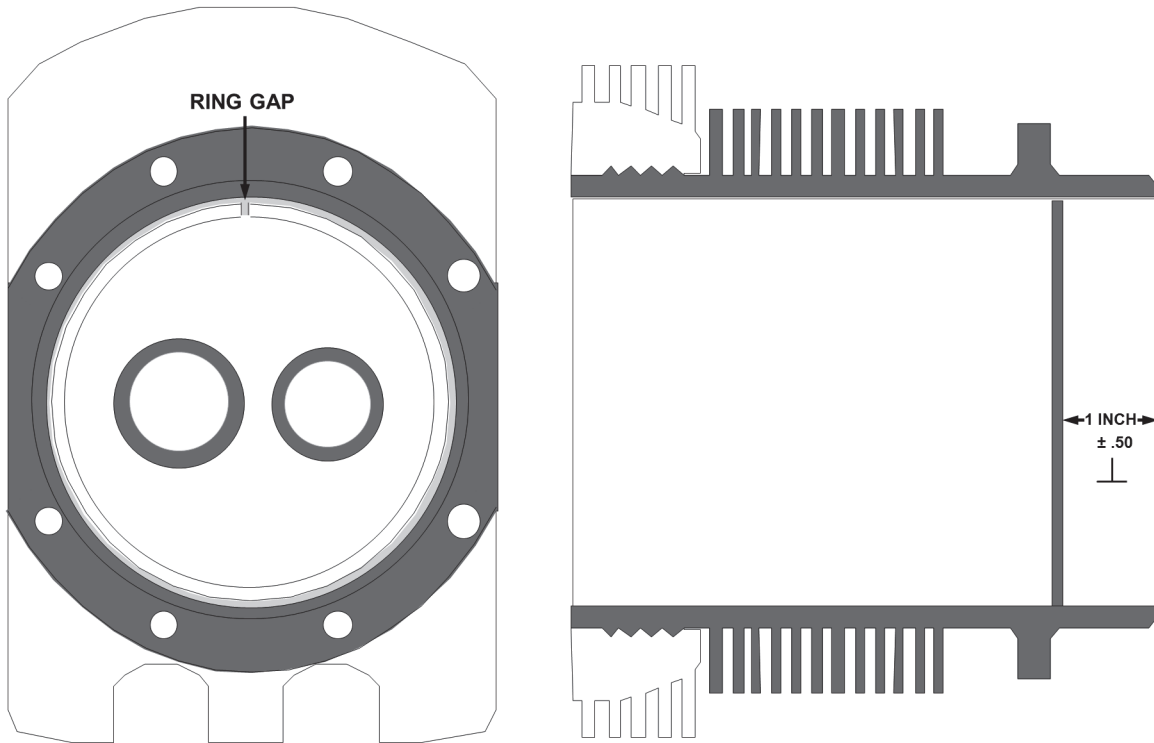

Figure 10-18. Ring Gap Measurement Location

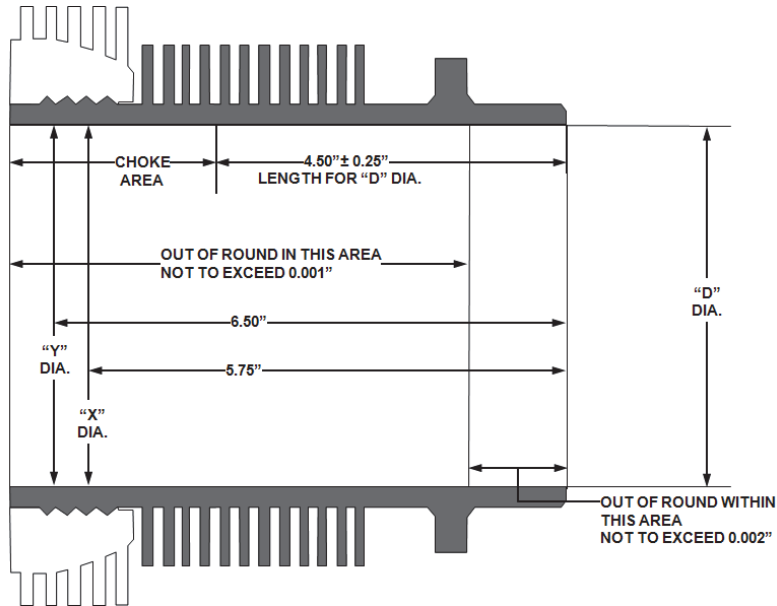

Figure 10-19. 5.000 Inch Cylinder Measurement Locations

Table 10-13. 5.000 Inch Cylinder Barrel Dimensions
Applicable to E-Series: O470, IO470, TSIO470

Size	"D" Diameter (inches)			"X" Diameter (inches)			"Y" Diameter (inches)		
	Minimum	Maximum	Service Limit	Minimum	Maximum	Service Limit	Minimum	Maximum	Service Limit
STD.	5.001	5.003	5.006	4.997	5.000	5.007	4.994	4.997	N/A
.005	5.006	5.008	5.011	5.002	5.005	5.012	4.999	5.002	N/A
.010	5.011	5.013	5.016	5.007	5.010	5.017	5.004	5.007	N/A
.015	5.016	5.018	5.021	5.012	5.015	5.022	5.009	5.012	N/A

Cylinder bore out of round: new cylinder must not exceed 0.001" in barrel above flange; service limit must not exceed 0.003" at measured diameters.

Table 10-14. Piston to Cylinder Clearance
All O470 Series (except O470-4, 13, 13A, K, L, R, & S), IO470, TSIO470-B, C, & D, E-Series

5.000 Inch Piston	Piston in Cylinder (new)
All Non-Coated	0.011 - 0.014 LOOSE
Manganese Phosphate Coated	
Measure clearance perpendicular to piston pin bore at "D" diameter Measure at the piston pin centerline perpendicular to piston pin bore.	



Table 10-15. Piston to Cylinder Clearance
O470-4, 13, 13A, K, L, R, & S

5.000 Inch Piston	Piston in Cylinder (new)
All Non-Coated	0.009 - 0.012 LOOSE
Manganese Phosphate Coated	
Measure clearance perpendicular to piston pin bore at "D" diameter Measure at the bottom of piston skirt perpendicular to piston pin bore.	

Table 10-16. Ring Gap Specifications
5.000 Inch Cylinder - All E-Series, O470, IO470, TSIO470

RING	Part Number	5.000 Gage Diameter	Gap	Service Gap
Ring Set, 6 cyl.	649226A1	N/A	N/A	N/A
Top Ring	648009	0.024 - 0.032	0.027 - 0.041	0.027 - 0.050
Second Ring	648010	0.020 - 0.030	0.023 - 0.039	0.023 - 0.048
Oil Control Ring	648011	0.012 - 0.022	0.015 - 0.031	0.015 - 0.040
Fourth Ring / Skirt	648012	0.012 - 0.022	0.015 - 0.031	0.015 - 0.040

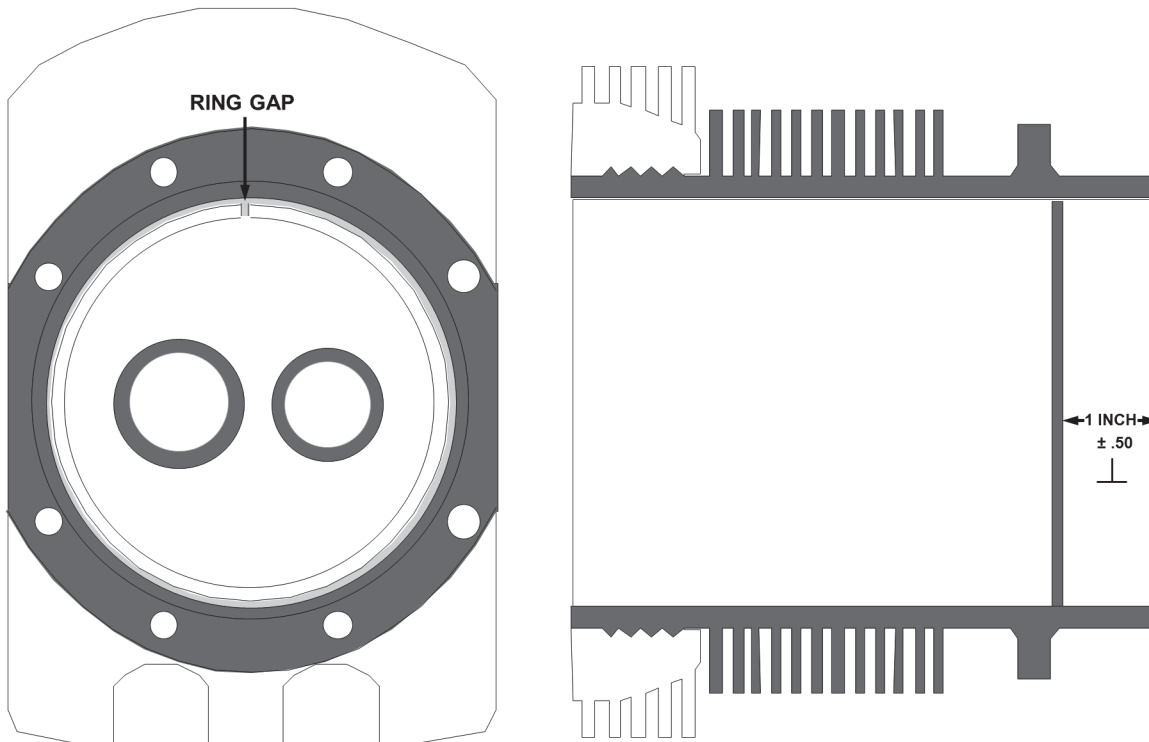

Figure 10-20. Ring Gap Measurement Location

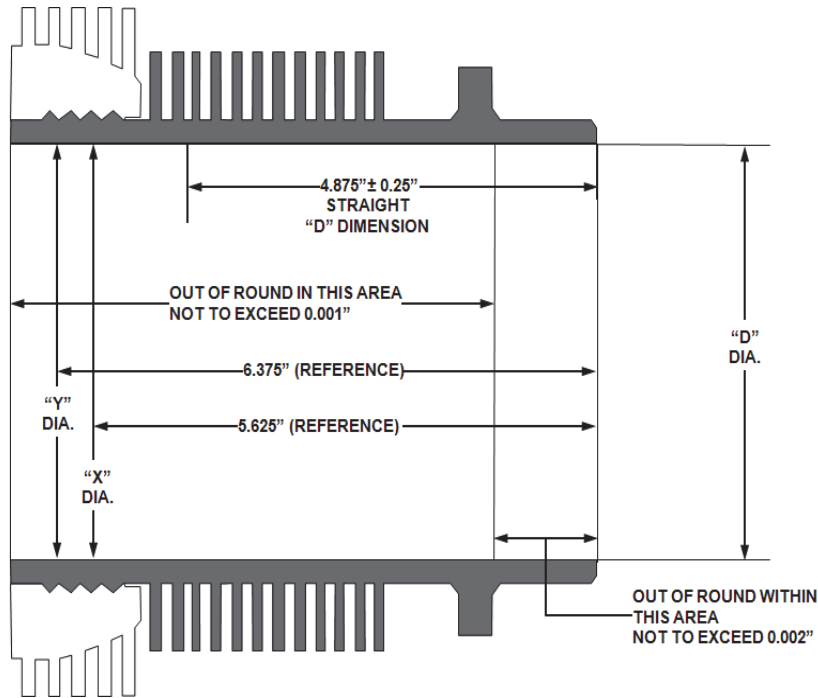

Figure 10-21. 4.438 Inch Cylinder Measurement Locations

Table 10-17. 4.438 Inch Cylinder Barrel Dimensions
Applicable to ALL IO240, IOF240, IO360, LTSIO360, and TSIO360

Size	"D" Diameter (inches)			"X" Diameter (inches)			"Y" Diameter (inches)		
	Minimum	Maximum	Service Limit	Minimum	Maximum	Service Limit	Minimum	Maximum	Service Limit
STD.	4.437	4.439	4.442	4.434	4.437	4.444	4.431	4.434	N/A
.005	4.442	4.444	4.447	4.439	4.442	4.449	4.436	4.439	N/A
.010	4.447	4.449	4.452	4.444	4.447	4.454	4.441	4.444	N/A
.015	4.452	4.454	4.457	4.449	4.452	4.459	4.446	4.449	N/A

Cylinder bore out of round: new cylinder must not exceed 0.001" in barrel above flange; service limit must not exceed 0.003" at measured diameters.

Table 10-18. Piston to Cylinder Clearance
Applicable to ALL IO240, IOF240, LTSIO360, IO360, and TSIO360

4.438 Inch Piston	Piston in Cylinder (new)
All Non-Coated	0.009 - 0.012 LOOSE
Manganese Phosphate Coated	
Measure clearance perpendicular to piston pin bore at "D" diameter Measure at the piston pin centerline perpendicular to piston pin bore.	



Table 10-19. Ring Gap Specifications
ALL IO240, IOF240, IO360, LTSIO360, and TSIO360

RING	Part Number	4.4375 Gage Diameter	Gap	Service Gap
Ring Set, 4 cyl.	649225A2	N/A	N/A	N/A
Ring Set, 6 cyl.	649225A1	N/A	N/A	N/A
Top Ring	648039	0.024 - 0.032	0.022 - 0.037	0.022 - 0.046
Second Ring	648040	0.030 - 0.038 ¹	0.028 - 0.043 ¹	0.028 - 0.052 ¹
Oil Control Ring	648041	0.010 - 0.020	0.008 - 0.025	0.008 - 0.034
Fourth Ring / Skirt	648042	0.012 - 0.022	0.010 - 0.027	0.010 - 0.036

1. Gap for second ring is nominally 0.006" larger than the top ring

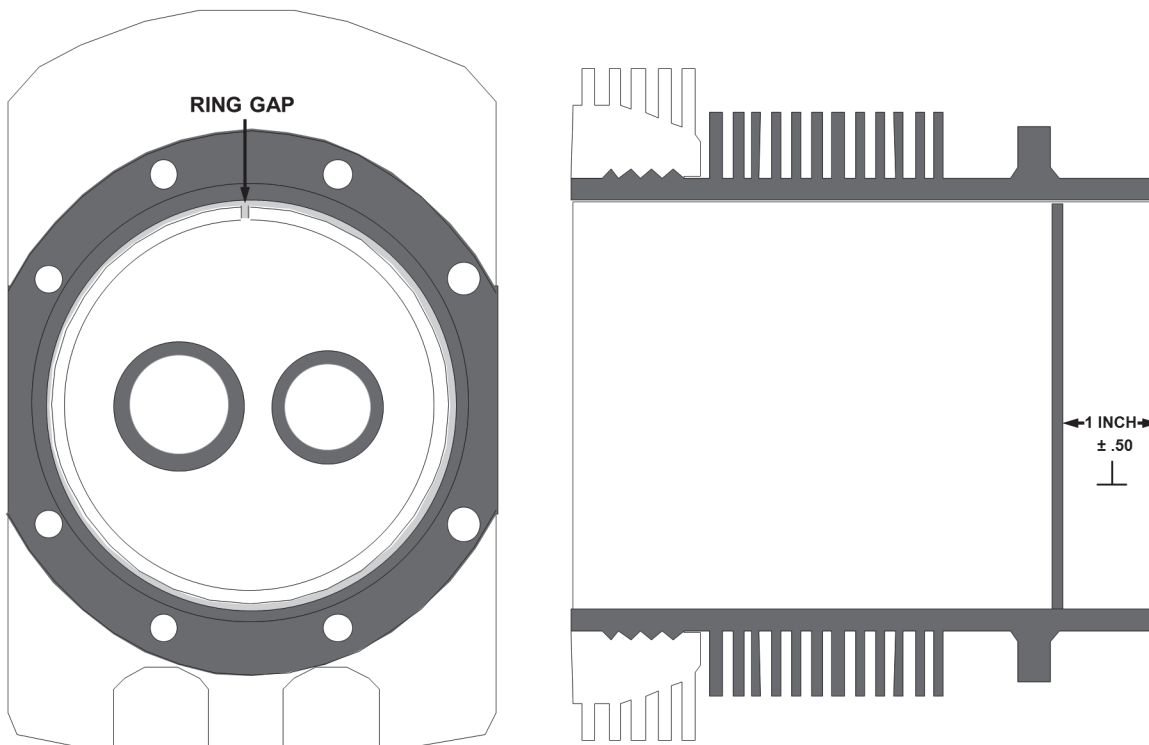

Figure 10-22. Ring Gap Measurement Location

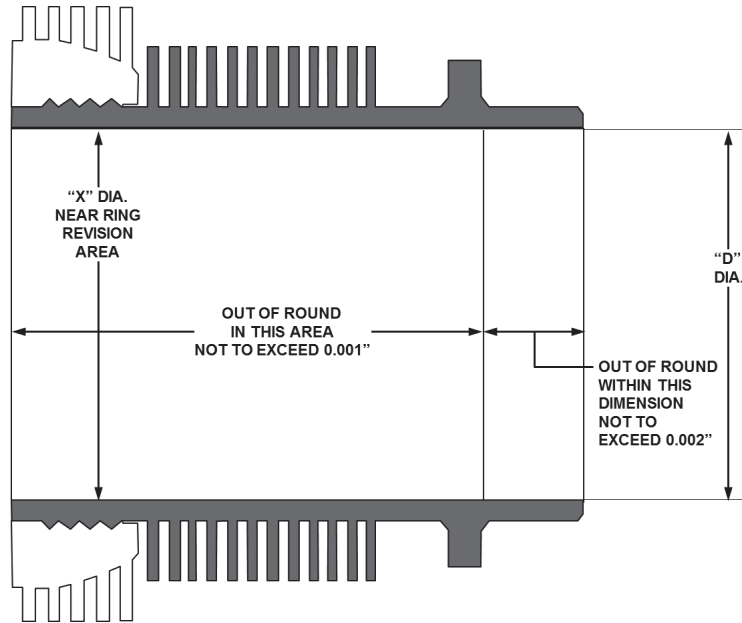

Figure 10-23. 4.062 Inch Cylinder Measurement Locations

Table 10-20. 4.062 Inch Cylinder Barrel Dimensions
Applicable to C75, C85, C90, C115, C125, C145, O200, O300, GO300

Size	"X" Diameter (inches)			Service Limit	Straight Barrel
	Minimum	Maximum	No Choke		
STD.	4.0615	4.0635	4.0665	N/A	
.005	4.0665	4.0685	4.0715		
.015	4.0765	4.0785	4.0815		

Cylinder bore out of round: new cylinder must not exceed 0.001" in barrel above flange; service limit must not exceed 0.003" at measured diameters.

Table 10-21. Piston to Cylinder Clearance
Applicable to C75, C85, C90, C115, C125, C145, O200, O300, GO300

4.062 Inch Piston	Piston in Cylinder (new)
All Non-Coated	0.008 - 0.011 LOOSE (C90, C145, O200, O300, GO300)
Manganese Phosphate Coated	0.009 - 0.012 LOOSE (C75, C85, C115)

Measure clearance perpendicular to piston pin bore at "D" diameter.
Measure C75, C85, C115, and C125 at the **bottom** of piston skirt perpendicular to piston pin bore.
Measure C90, C145, O200, O300 and GO300 **above 4th ring** perpendicular to piston pin bore.



Table 10-22. Ring Gap Specifications
Applicable to C75, C85, C90, C115, C125, C145, O200-A, B, & C, O300, GO300

RING	Part Number	4.0625 Gage Diameter	Gap	Service Gap
Ring Set, 4 cyl.	649632A2	N/A	N/A	N/A
Ring Set, 6 cyl	649632A3	N/A	N/A	N/A
Top Ring	649632	0.023 - 0.031	0.020 - 0.034	0.020 - 0.043
Second Ring	638110	0.029 - 0.037	0.026 - 0.040	0.026 - 0.049
Third Ring	638110	0.029 - 0.037	0.026 - 0.040	0.026 - 0.049
Oil Control Ring	638111	0.015 - 0.025	0.012 - 0.028	0.012 - 0.037

Table 10-23. Ring Gap Specifications
O200D ONLY

RING	Part Number	4.0625 Gage Diameter	Gap	Service Gap
Ring Set	657480	N/A	N/A	N/A
Top Ring	657479	0.023 - 0.031	0.020 - 0.034	0.020 - 0.043
Second Ring	638110	0.029 - 0.037	0.026 - 0.040	0.026 - 0.049
Third Ring	657548	0.015 - 0.025	0.012 - 0.028	0.012 - 0.037

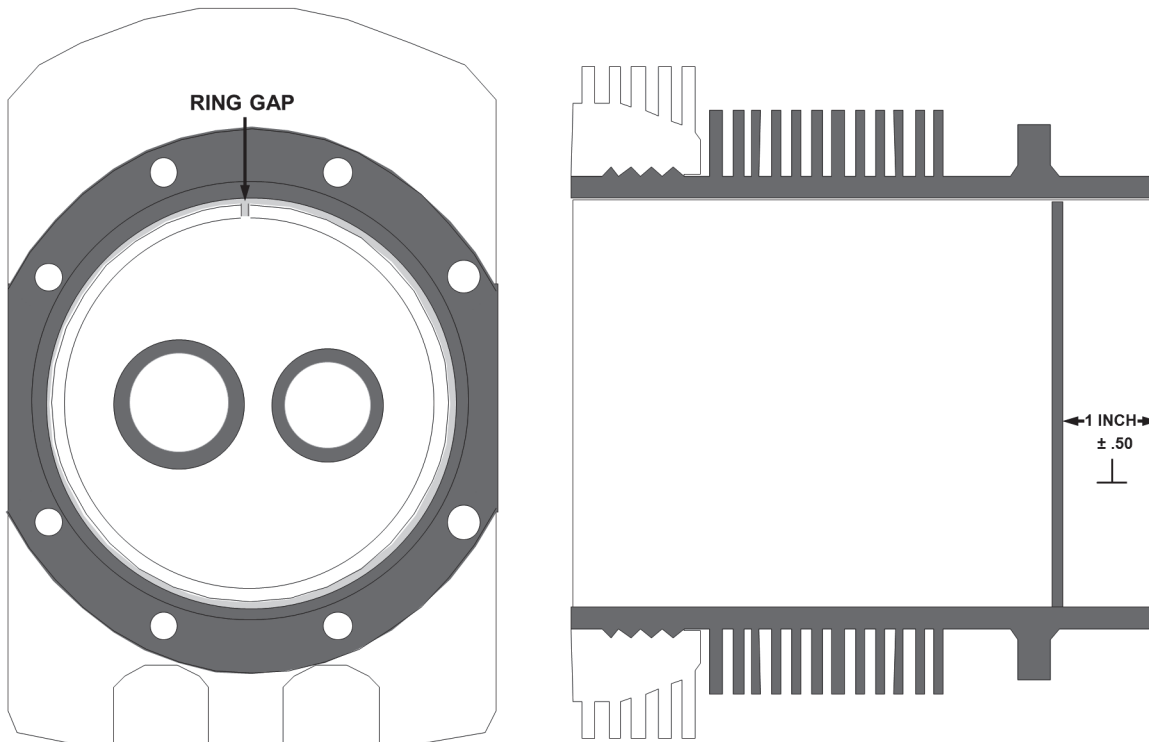

Figure 10-24. Ring Gap Measurement Location



Table 10-24. Engine to Piston Cross Reference

NOTE: *Non-coated pistons (with untreated skirt or graphite treated skirt) were discontinued in 1998 and are provided for reference only.

Engine Model	Non-coated Piston		Manganese Phosphate Coated Piston	Piston Diameter
	*untreated skirt	*graphite treated skirt		
C75, C85, C115, C125 (6.3:1 comp. ratio)	646287	N/A	654841	4.0514-4.0524
	N/A		654841P015	4.0664-4.0674
C90, C145 O200A, B O300A, C, D	N/A	654749	654853	4.0522-4.0532
		N/A	654853P015	4.0672-4.0682
O200D	N/A	N/A	657562	4.0522-4.0532
GO300	646279	N/A	654858	4.0522-4.0532
IO240A, B; IOF240B IO360A, AB, C, CB, D, DB, ES, G, GB, H, HB, J, JB, K, KB	648049	654728	654861	4.4270-4.4280
	N/A	N/A	654861P015	4.4420-4.4430
IO346A TSIO550B, C, E, G, K, N TSIOF550D, J, K, P TSIOL550A, B, C	N/A	N/A	657989	5.2422-5.2432
			657989P005	5.2472-5.2482
			657989P010	5.2522-5.2532
			657989P015	5.2572-5.2582
	649805	654731	N/A	5.2432-5.2442
	649805P005	654731P005		5.2482-5.2492
	649805P010	654731P010		5.2532-5.2542
649805P015	654731P015		5.2582-5.2592	
LTSIO360E, EB, KB, RB TSIO360A, AB, C, CB, D, DB, E, EB, F, FB, GB, H, HB, JB, KB, LB, MB, RB, SB	648048	654727	654859	4.4270-4.4280
	N/A	N/A	654859P015	4.4420-4.4430
O470K, L, R, S, -4, -13, -13A	646263	654744	654833	4.9907-4.9922
	N/A	N/A	654833P015	5.0057-5.0072
O470U IO470D, E, F, H, L, M, N, S, U, V, VO	648029	654722	654832	4.9887-4.9897
	N/A	N/A	654832P015	5.0037-5.0047
O470G, M, P O470GCI, MCI IO470C, G, P, R	648028	654721	654829	4.9887-4.9897
O470-7A, 7B, 11, 11CI, 15, A, E, J IO470J, K E165, E185, E225	649044	654729	654862	4.9887-4.9897
	N/A	N/A	654832P015	5.0037-5.0047
TSIO470B, C, D	N/A	N/A	655988	4.9887-4.9897
GTSIO520C, D, H, K, L, M, N TSIO520AF, B, BB, BE, C, CE, D, DB, E, EB, G, H, J, JB, K, KB, L, LB, M, N, NB, P, R, T, UB, VB, WB	648044	654724	654840	5.2420-5.2430
	N/A	N/A	654840P010	5.2520-5.2530
			654840P015	5.2570-5.2580



Non-Overhaul Repair and Replacement

Table 10-24. Engine to Piston Cross Reference

NOTE: *Non-coated pistons (with untreated skirt or graphite treated skirt) were discontinued in 1998 and are provided for reference only.

Engine Model	Non-coated Piston		Manganese Phosphate Coated Piston	Piston Diameter
	*untreated skirt	*graphite treated skirt		
IO520A, B, BA, BB, C, CB, D, E, F, J, K, L, M, MB, N, NB	648045	N/A	654850	5.2420-5.2430
	N/A		654850P010	5.2520-5.2530
			654850P015	5.2570-5.2580
IO520P LIO520P LTSIO520AE TSIO520AE	648037	654723	654836	5.2420-5.2430
	N/A	N/A	654836P010	5.2520-5.2530
			654836P015	5.2570-5.2580
IO550A, B, C, D, E, F, G, L, N, P, R IOF550B, C, D, E, F, L, N, P & R	648046	654726	654857	5.2420-5.2430
	N/A	N/A	654857P010	5.2520-5.2530
			654857P015	5.2570-5.2580

10-6.10. Legacy Product Replacement Valves

NOTE: Information contained in this section was originally published in Service Bulletin M76-8.

Applicable Engines:

C-75, C-85, C-90, O-200 (except -D and -X), O-300 and GO-300

Applicable Engine Serial Numbers:

Table 10-25. Engines Serial Number Applicability

Engine Model	Engine Serial Numbers		
	New Engine	Rebuilt Engine	Factory Overhauled Engine
O-200-A	254178 ¹	6645-R	901140-0
O-300-A	N/A ²	16092-R	901146-0
O-300-C	N/A	23223-R	N/A
O-300-D	N/A	25560-R	N/A
C-90	N/A	N/A	901169-0

1. It is possible that some O-200-A new engines prior to S/N 254178 were built incorporating 30° face intake valves. When servicing any O-200-A engine cylinders, check the part number stamped on the cylinder base flange before installing valves.
2. New engine production terminated prior to product improvement.

Many low compression engines, originally certified for operation with 80/87 fuel, experience lead build-up or spark plug fouling as a result of the higher octane and lead content of 100/100LL(Ref: Section 7-2.2). To improve intake valve service life, Continental Motors introduced new intake valve designs in 1976. Design changes to the



valve and valve seat angle and a new valve seat material were incorporated in all new and rebuilt engines manufactured after May 19, 1976. Aftermarket parts were made available to the field after May 28, 1976.

The components listed in the third column of Table 10-26 were designed to improve operation of low compression ratio engines with 100/100LL fuels. Further improvements since 1976 required redesign of the original replacement parts with new part numbers. The current replacement part numbers, as of the publication date of this document are listed in the far right column. See Section 1-4 for more information regarding service parts.

Table 10-26. Replacement Components for Low Compression Ratio Cylinders

Engine Model	Component	Original Replacement Part Number	Current Replacement Part Number
A65, A75	Intake Valve	639661	657512
	Exhaust Valve	639662	655972
GO-300	Intake Valve	641792	655968
	Intake Valve Seat	641793	655530
	Exhaust Valve	631639	655969
C-75, C-85, C-90, C-125, C-145 O-200, O-300	Intake Valve	641792	655968
	Intake Valve Seat	641793	655530

Intake valve, part number 531608 and the intake valve seat insert, part number 3912 installed in the above engine models prior to May 1976 are no longer available and, if discovered during overhaul or cylinder inspection, should be removed and replaced with the current part numbers, or subsequent replacement part numbers, regardless of the condition of the installed valves and valve seats.

The improved valve design is commonly referred to as a “30° angle valve” indicating the valve face is ground at a 30° offset angle from the surface of the head in the combustion chamber; however the standard practice (see Figure 10-25) for design engineering is to reference the valve face dimension off the valve stem centerline and the valve seat insert off the valve guide centerline.

Table 10-27. Cylinder Part Number Conversion

Original Part Number	New Part Number
A50222	641916
639702	641916
626710	641917
639703	641917

After installation of the new valve and valve guide, the cylinder assembly will no longer meet the specifications of the part number identified on the base flange. Cross out the



Non-Overhaul Repair and Replacement

original part number on the base flange with a steel stamp letter “X” and stamp the cylinder with the following part numbers adjacent to the previous part number:

Valve seats are sold unfinished. After installation, the valve seats must be ground, in reference to the valve guide. Reference valve seat grinding instructions in the primary ICA. Grind the new valve seats to the dimensions specified in Figure 10-25. The new valve seat angle should be $60^{\circ} +30' / -0'$. Valve seat width should be 0.060” wide, not to exceed the maximum O.D. specified in the primary ICA. To narrow the width of the valve seat after grinding, top off with a 75° stone, as depicted in Figure 10-25. Valve lapping, according to instructions in the primary ICA is permitted to optimize the valve face and valve seat mating surfaces.

CAUTION: All lapping compound must be removed from the valves, valve seats and cylinder assembly before cylinder installation.

Make a log book entry indicating compliance with **M76-8** and **M-0**.

CAUTION: Instructions in Figure 10-25 apply to rework of the valves and valve guides in the subject cylinder assemblies discussed in Section 10-6.10 only. Instructions are not standard for all intake valves and valve guides.

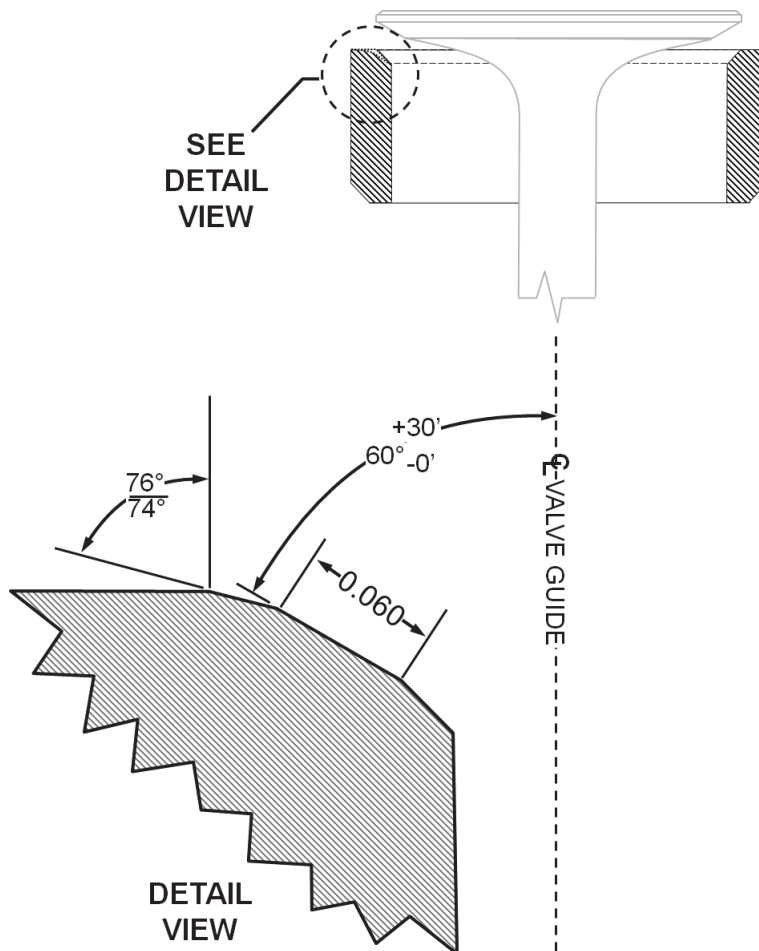

Figure 10-25. Intake Valve Angle



10-7. Crankcase Repair

WARNING

Weld repairs are NOT permitted in the critical (non-shaded) areas of the crankcase or the bearing support structures. An FAA-approved repair facility is the only facility authorized to perform a crankcase weld repair.

Crankcase welding is not an in-service repair. The engine must be removed from the aircraft, disassembled, and soaked in solvent to remove flammable material. Welding is only permitted on non-critical areas of the crankcase identified in Figure 6-81 through Figure 6-88. Only a Part 145 Repair Station, certified to perform crankcase welding may complete the repair. The dimensional integrity of the crankcase must be maintained. Record crankcase repair in the engine log book:

1. Engine total time in service
2. Method of inspection following repair (visual, dye penetrant, or other)
3. Identify location of crack repair area
4. Structural and dimensional characteristics of repaired crack
5. Date



10-8. Piston Replacement

CAUTION: The removal of metal from connecting rods, crankshafts or pistons, for the purposes of balancing, is not an approved procedure. Indiscriminate work of this type, accomplished without the benefits of renitriding, shot peening and/or heat treatment can seriously compromise the structural integrity of the engine.

NOTE: The allowable weight variation between connecting rods or pistons does not apply to the entire set. Connecting rods and pistons weight variations are limited to opposing cylinder bays. For four cylinder engines, pistons in cylinders 1 and 2 must be matched within one half ounce. Pistons in cylinders 3 and 4 must match the same criteria. For six cylinder engines, the pistons in cylinders 5 and 6 must be matched within one half ounce as well as the previously mentioned criteria for cylinders 1 through 4 in the four cylinder engines.

Pistons are selected in pairs with a maximum weight variation not to exceed 1/2 ounce in opposing bays.



10-9. Crankshaft Repair

WARNING

Crankshafts may only be repaired by an approved FAA Part 145 Repair Stations. Do not attempt crankshaft repair without the required FAA certification.

CAUTION: Do not attempt to repair a scored or overheated crankshaft. Discard and replace scored or scorched crankshafts.

If a crankshaft is repaired by an FAA Repair Station, the nitride treatment must be restored.

Crankshaft overhaul repairs must be performed by an FAA Part 145 Repair Station certified to perform crankshaft repair using methods approved by the Federal Aviation Administration. The repaired crankshaft must meet the dimensional limits specified in the primary Instructions for Continued Airworthiness.

1. Remove the crankshaft counterweights according to the instructions in Section 10-9.1.1.
2. Identify the counterweight using the illustrations in Section 10-9.1.2. Inspect the Counterweight assemblies according to the instructions in Section 10-9.1.3. Replace Counterweight Bushings according to the instructions in Section 10-9.1.5.
3. Inspect the Hanger Blade Bushings according to the instructions in Section 10-9.1.6. Replace Hanger Blade Bushings, as required, according to the instructions in Section 10-9.1.5.
4. Install the Crankshaft Oil Control Plug according to the instructions in Section 10-9.2.
5. After the crankshaft hanger blade bushing replacement, counterweight replacement, counterweight bushings replacement, or the oil control plug is replaced, perform a “Magnetic Particle Inspection” on the crankshaft and counterweights and a “Crankshaft Ultrasonic Inspection” to ensure no cracks developed during the bushing or plug installation process.

10-9.1. Crankshaft Counterweight Inspection and Repair

This Section is divided in subsections, consisting of multiple tables listing the engine power train major component part numbers (Table 10-28), parts supersedure (Table 10-32), and repair instructions for crankshaft counterweights and connecting rods (Table 10-38).

Use Table 10-28 to locate the engine crankshaft part number and subsequent tables in this section to determine the appropriate counterweight and connecting rod repair instructions.

To determine appropriate piston and piston rings to mate with the connecting rods, refer to the Tables in Section 10-6.9.



Non-Overhaul Repair and Replacement

Table 10-28. Engine Power Train

Engine Model	Crankshaft Assembly	Connecting Rod ¹	Connecting Rod Bearing	Bearing Set	Oil Control Collar
A-65	530199A1	A35160A2	639640	627246A2	N/A
				530058A6 ²	N/A
A-75	530199A1	A35160A2	639640	627246A2	N/A
				530058A6 ²	N/A
C-75	530196A1 ³	A35160A2	639640	530058A4	N/A
	530199A1 ⁴			530058A5	N/A
C-85	530196A1 ³	A35160A2	639640	530058A4	N/A
	530199A1 ⁴			530058A5	N/A
C-90	530182 ⁵	654795	639640	530058A4	N/A
				530058A5	N/A
C-145-2	530860	654795	639640	530058A4	N/A
				530058A5	N/A
C-145-2H	531113	654795	639649	652152A1	N/A
				530058A5	N/A
E-165	352174A2	A36121	530383	646149A1	N/A
E-185-1, 3, 8, 9	537561	A36121	530383	646149A1	N/A
E-185-1, 3, 8, 9	352174	A36121	530383	646149A1	N/A
E-225-4, 8	537561	A36121	530383	646149A1	N/A
O-200-A	653012	654795	639640	627246A2 530058A6 ²	N/A
O-200-B	653012	654795	639640	627246A2 530058A6 ²	N/A
O-200-D & X	657466	654795	639640-UPPER 657564-LOWER	530058A7 ²	N/A
O-240	637069	654794	639640	637062A2	N/A
O-300-A	530860	654795	639640	652152A1	N/A
O-300-B	531113	654795	639640	530516A2	N/A
O-300-C	653382	654795	639640	652152A1	N/A
O-300-D	653382	654795	639640	652152A1	N/A
O-470-2			No Longer Supported		
O-470-4			No Longer Supported		
O-470-7			No Longer Supported		
O-470-11			No Longer Supported		
O-470-13A			No Longer Supported		
O-470-15			No Longer Supported		



Table 10-28. Engine Power Train

Engine Model	Crankshaft Assembly	Connecting Rod ¹	Connecting Rod Bearing	Bearing Set	Oil Control Collar
O-470-A	649141	655910	630826	537401A3 ⁶ 646589A1 ⁷ 646590A1 ⁸	N/A
O-470-B	653697	655910	630826	537401A3 ⁶ 646589A1 ⁷	N/A
O-470-C	649141	655910	630826	537401A3 ⁶	N/A
O-470-E	649141	655910	630826	537401A3 ⁶ 646589A1 ⁷ 646590A1 ⁸	N/A
O-470-G	652005	655910	630826	646591A3 ⁸ 646588A1 ⁷ 646807A1 ⁹ 627795A3 ^{6 10}	626739
O-470-J	649141	655910	630826	537401A3 ⁶ 646589A1 ⁷ 646590A2 ⁸	N/A
O-470-K	652039	655910	630826	537401A3 ⁶ 646589A1 ⁷ 646590A2 ⁸	N/A
O-470-L	652039	655910	630826	537401A3 ⁶ 646589A1 ⁷ 646590A2 ⁸	N/A
O-470-M	652039	655910	630826	646807A1 ⁶ 646589A1 ⁷ 646590A2 ⁸	N/A
O-470-N	653697	655910	630826	537401A3 ⁶ 646589A1 ⁷	N/A
O-470-P	652011	655910	630826	646591A3 ⁸ 646588A1 ⁷ 627795A3 ^{6 9}	
O-470-R	649141	655910	630826	537401A3 ⁶ 646589A1 ⁷ 646590A2 ⁸	N/A
O-470-S	649141	655910	630826	646589A1 ⁷ 646590A2 ⁸	N/A



Non-Overhaul Repair and Replacement

Table 10-28. Engine Power Train

Engine Model	Crankshaft Assembly	Connecting Rod ¹	Connecting Rod Bearing	Bearing Set	Oil Control Collar
O-470-U	649138	655910	630826	646589A1 ⁷ 646590A2 ⁸	N/A
GO-300-A, C, D, E	627822	654794A1	639640	626943A1	N/A
GTSIO-520-C	653020	655910	630826	633024A2	N/A
GTSIO-520-D	653020	655910	630826	633024A2	N/A
GTSIO-520-H	653020	655910	630826	633024A2	N/A
GTSIO-520-K	653020	655910	630826	633024A2	N/A
GTSIO-520-L	653020	655910	630826	633024A2	N/A
GTSIO-520-M	653020	655910	630826	633024A2	N/A
GTSIO-520-N	653020	655910	630826	633024A2	N/A
IO-240-A	653164	654793A1	642338	637062A3	N/A
IO-240-B	653164	654793A1	642338	637062A3	N/A
IOF-240-B	653164	654793A1	642338	637062A3	N/A
IO-346-A	630778	655910	630826	646594A1	N/A
IO-360-A	653138	654794A1	639640	646595A1	N/A
IO-360-AB	653129	654793A1	642338	646597A1	N/A
IO-360-AF	653129	654793A1	642338	646597A1	N/A
IO-360-C	653138	654794A1	639640	646595A1	N/A
IO-360-CB	653129	654793A1	642338	646597A1	N/A
IO-360-D	653138	654794A1	639640	646595A1	N/A
IO-360-DB	653129	654793A1	642338	646597A1	N/A
IO-360-ES	653129	654793A1	642338	646597A1	N/A
IO-360-G	653139	654794A1	639640	646595A1	N/A
IO-360-GB	653129	654793A1	642338	646597A1	N/A
IO-360-H	653139	654794A1	639640	646595A1	N/A
IO-360-HB	653129	654793A1	642338	646597A1	N/A
IO-360-J	653139	654794A1	639640	646595A1	N/A
IO-360-JB	653129	654793A1	642338	646597A1	N/A
IO-360-K	653139	654794A1	639640	646595A1	N/A
IO-360-KB	653129	654793A1	642338	646597A1	N/A
IO-470-C	652011	655910	630826	627795A3 ⁶ 646588A1 ⁷ 646591A3 ⁸	626739
IO-470-D	649133	655910	630826	627795A3 ⁶ 646588A1 ⁷ 646591A3 ⁸	626739



Table 10-28. Engine Power Train

Engine Model	Crankshaft Assembly	Connecting Rod ¹	Connecting Rod Bearing	Bearing Set	Oil Control Collar
IO-470-E	649133	655910	630826	627795A3 ⁶ 646588A1 ⁷ 646591A3 ⁸	626739
IO-470-F	649133	655910	630826	627795A3 ⁶ 646588A1 ⁷ 646591A3 ⁸	626739
IO-470-H	652011	655910	630826	627795A3 ⁶ 646588A1 ⁷ 646591A3 ⁸	626739
IO-470-J	652009	655910	630826	627795A3 ⁶ 646588A1 ⁷ 646591A3 ⁸	626739
IO-470-K	652009	655910	630826	627795A3 ⁶ 646588A1 ⁷ 646591A3 ⁸	626739
IO-470-L	652010	655910	630826	627795A3 ⁶ 646588A1 ⁷ 646591A3 ⁸	626739
IO-470-M	649133	655910	630826	627795A3 ⁶ 646588A1 ⁷ 646591A3 ⁸	626739
IO-470-N	652011	655910	630826	627795A3 ⁶ 646588A1 ⁷ 646591A3 ⁸	626739
IO-470-R	630977	A36121	530383	627795A3 ⁶ 646588A1 ⁷ 646591A3 ⁸	626739
IO-470-S	649133	655910	630826	627795A3 ⁶ 646588A1 ⁷ 646591A3 ⁸	626739
IO-470-U	649135	655910	630826	627795A3 ⁶ 646588A1 ⁷ 646591A3 ⁸	626739
IO-470-V	649135	655910	630826	627795A3 ⁶ 646588A1 ⁷ 646591A3 ⁸	626739



Non-Overhaul Repair and Replacement

Table 10-28. Engine Power Train

Engine Model	Crankshaft Assembly	Connecting Rod ¹	Connecting Rod Bearing	Bearing Set	Oil Control Collar
IO-520-A	649134	655910	630826	646588A1 ⁷ 646591A3 ⁸	626739
IO-520-B	649895	655910	630826	646593A2	629680
IO-520-BA	649896	655910	630826	646593A2	629680
IO-520-BB	649898	655911	642398	646592A2	629680
IO-520-C	649895	655910	630826	646593A2	629680
IO-520-CB	649898	655911	642398	646592A2	629680
IO-520-D	649134	655910	630826	646588A1 ⁷ 646591A3 ⁸	626739
IO-520-E	649134	655910	630826	646588A1 ⁷ 646591A3 ⁸	626739
IO-520-F	649134	655910	630826	646588A1 ⁷ 646591A3 ⁸	626739
IO-520-J	649134	655910	630826	646588A1 ⁷ 646591A3 ⁸	626739
IO-520-K	649134	655910	630826	646588A1 ⁷ 646591A3 ⁸	626739
IO-520-L	649134	655910	630826	646588A1 ⁷ 646591A3 ⁸	626739
IO-520-M ⁵	649895	655910	630826	646593A2	629680
IO-520-MB	649898	655911	642398	646592A2	629680
IO-520-P	649144-1	655910	630826	646593A2	629739
IO-550-A	649900	655911	642398	646592A2	629680
IO-550-B	649900	655911	642398	646592A2	629680
IO-550-B29B, 33B, 37B	649900	655912	642398	646592A2	629680
IO-550-C	649900	655911	642398	646592A2	629680
IO-550-C25B, 29B, 30B	649900	655912	642398	646592A2	629680
IO-550-D	646623	655911	642398	646592A2	626739
IO-550-E	646623	655911	642398	646592A2	626739
IO-550-F	646623	655911	642398	646592A2	626739
IO-550-G	649900	655911	642398	646592A2	629680
IO-550-L	646623	655911	642398	646592A2	626739
IO-550-N	649900	655911	642398	646592A2	629680
IO-550-P	649900	655911	642398	646592A2	629680
IO-550-R	649900	655911	642398	646592A2	629680
IOF-550-B, C	649900	655911	642398	646592A2	629680



Table 10-28. Engine Power Train

Engine Model	Crankshaft Assembly	Connecting Rod ¹	Connecting Rod Bearing	Bearing Set	Oil Control Collar
IOF-550-D, E, F, L	646623	655911	642398	646592A2	626739
IOF-550-N, P, R	649900	655911	642398	646592A2	629680
LTSIO-360-E	653137	654794	639640	646597A2	N/A
LTSIO-360-EB	653136	654793	642338	646597A1	N/A
LTSIO-360-KB	653136	654793	642338	646597A1	N/A
LTSIO-360-RB	653136	654793	642338	646597A1	N/A
LTSIO-520-AE	649144-2	655000	630826	646591A4	626739
TSIO-360-A	653138	654794	639640	646595A1	N/A
TSIO-360-AB	653129	654793	642338	646597A1	N/A
TSIO-360-B	653138	654794	639640	646595A1	N/A
TSIO-360-C	653139	654794	639640	646595A1	N/A
TSIO-360-CB	653129	654793	642338	646597A1	N/A
TSIO-360-D	653139	654794	639640	646595A1	N/A
TSIO-360-DB	653129	654793	642338	646597A1	N/A
TSIO-360-E	653139	654794	639640	646597A2	N/A
TSIO-360-EB	653129	654793	642338	646597A1	N/A
TSIO-360-F	653139	654794	639640	646595A1	N/A
TSIO-360-FB	653129	654793	642338	646597A1	N/A
TSIO-360-G	653139	654794A1	639640	646595A1	N/A
TSIO-360-GB	653129	654793	642338	646597A1	N/A
TSIO-360-H	653139	654794	639640	646595A1	N/A
TSIO-360-HB	653129	654793	642338	646597A1	N/A
TSIO-360-JB	653129	654793	642338	646597A1	N/A
TSIO-360-KB	653129	654793	642338	646597A1	N/A
TSIO-360-MB	653129	654793	642338	646597A1	N/A
TSIO-360-RB	653129	654793	642338	646597A1	N/A
TSIO-360-SB	653129	654793	642338	646597A1	N/A
TSIO-470-B	652011	646437A2	630826	627795A3 ⁶ 646588A1 ⁷	626739
TSIO-470-C	652011	646437A2	630826	627795A3 ⁶ 646588A1 ⁷	626739
TSIO-470-D	652011	646437A2	630826	627795A3 ⁶ 646588A1 ⁷	626739
TSIO-520-AE	649144-1	655000	630826	646591A4	626739
TSIO-520-AF	649134	655004	630826	646591A3 ⁸	626739
TSIO-520-B	649895	655004	630826	646593A2	629680



Non-Overhaul Repair and Replacement

Table 10-28. Engine Power Train

Engine Model	Crankshaft Assembly	Connecting Rod ¹	Connecting Rod Bearing	Bearing Set	Oil Control Collar
TSIO-520-BB	649898	655005	642398	646592A2	629680
TSIO-520-BE	649898	655005	642398	646592A2	629680
TSIO-520-C	649134	655004	630826	646588A1 ⁷ 646591A3 ⁸	626739
TSIO-520-CE	649148	655001	642398	646592A2	626739
TSIO-520-D	649895	655004	630826	646593A2	629680
TSIO-520-E	649895	655004	630826	646593A2	629680
TSIO-520-EB	649898	655005	642398	646592A2	629680
TSIO-520-H	649134	655004	630826	646588A1 ⁷ 646591A3 ⁸	626739
TSIO-520-J	649895	655004	630826	646593A2	629680
TSIO-520-JB	649898	655005	642398	646592A2	629680
TSIO-520-K	649895	655004	630826	646593A2	629680
TSIO-520-KB	649898	655005	642398	646592A2	629680
TSIO-520-L	649895	655004	630826	646593A2	629680
TSIO-520-LB	649898	655005	642398	646592A2	629680
TSIO-520-M	649134	655004	630826	646588A1 ⁷ 646591A3 ⁸	626739
TSIO-520-N	649895	655004	630826	646593A2	629680
TSIO-520-NB	649898	655005	642398	646592A2	629680
TSIO-520-P	649134	655004	630826	646588A1 ⁷ 646591A3 ⁸	626739
TSIO-520-R	649134	655004	630826	646588A1 ⁷ 646591A3 ⁸	626739
TSIO-520-T	649134	655004	630826	646588A1 ⁷ 646591A3 ⁸	626739
TSIO-520-UB	649898	655005	642398	646592A2	629680
TSIO-520-VB	649898	655005	642398	646592A2	629680
TSIO-520-WB	649898	655005	642398	646592A2	629680
TSIO-550-A	649900	655001	642398	646592A2	629680
TSIO-550-B	649900	655001	642398	646592A2	629680
TSIO-550-C	649900	655001	642398	646592A2	629680
TSIO-550-G	649900	655001	642398	646592A2	629680
TSIO-550-K	649900	655001	642398	646592A2	629680
TSIO-550-N	649900	655001	642398	646592A2	629680
TSIOF-550-D	649900	655001	642398	646592A2	629680



Table 10-28. Engine Power Train

Engine Model	Crankshaft Assembly	Connecting Rod ¹	Connecting Rod Bearing	Bearing Set	Oil Control Collar
TSIOF-550-J	649900	655001	642398	646592A2	629680
TSIOF-550-K	649900	655001	642398	646592A2	629680
TSIOL-550-A	652359	655001	642398	646592A2	629680
TSIOL-550-B	652359	655001	642398	646592A2	629680
TSIOL-550-C	652359	655001	642398	646592A2	629680

1. See Table 10-38 for new and old connecting rod part numbers and associate hardware usage
2. With 633141 thrust washer
3. Tapered crankshaft with removable prop flange
4. Propeller flange included with crankshaft forging
5. Non-production engine
6. Flange type bearing for use with Phase 1 style crankcase and crankshaft. See Service Bulletin M78-9 or latest revision.
7. Thrust washer type bearings for use with Phase 2 style crankcase and crankshaft. See Service Bulletin M78-9 or latest revision.
8. For use with Phase 3 style crankcase and crankshaft. See Service Bulletin M78-9 or latest revision.
9. For O-470-G engines with modernized crankshafts using oil transfer collar.
10. For O-470-G engines with modified crankshafts. Remove and discard nylon wipers for O-470-G

Table 10-29. Crankshaft Assembly Part Number History

Specification	Crankshaft Assembly	Supersedes	Supersedes	Supersedes	Supersedes
O-200-A	653012	531434			
O-200-B	653012	531434			
O-200-D & X	657466				
O-300-A	530860				
O-300-C	653382 ¹	652110	628124		
O-300-D	653382 ²	652110	628124		
O-470-A	649141	633225	537290		
O-470-B	653697	633227	539576		
O-470-C	649141	633225	537290		
O-470-E	649141	633225	537290		
O-470-F	649141	633225	537290		
O-470-G	652005	633256			
O-470-J	649141	633225	537290		
O-470-K	652039	633219	539665		
O-470-L	652039	633219	539665		
O-470-M	652039	633219	539665		
O-470-N	653697	633227	539576		



Non-Overhaul Repair and Replacement

Table 10-29. Crankshaft Assembly Part Number History

Specification	Crankshaft Assembly	Supersedes	Supersedes	Supersedes	Supersedes
O-470-R	649141	633225	537290		
O-470-S	649141	633225	537290		
O-470-U	649138	643911	641905		
GO-300-A, C, D, E	627822				
GIO-550-A ³	652800A1				
GTSIO-520-C	653020	652832	652821	652001	635104
GTSIO-520-D	653020	652832	652821	652001	635104
GTSIO-520-H	653020	652832	652821	652001	635104
GTSIO-520-K	653020	652832	652821	652001	635104
GTSIO-520-L	653020	652832	652821	652001	635104
GTSIO-520-M	653020	652832	652821	652001	635104
GTSIO-520-N	653020	652832	652821	652001	635104
IO-240-A	653164				
IO-240-B	653164				
IOF-240-B	653164				
IO-346-A	630778				
IO-360-A	653138	652047	649785	639200	634479
IO-360-AB	653129	652014	643627	642350	
IO-360-AF	653129				
IO-360-C	653138	652047	649785	639200	634479
IO-360-CB	653129	652014	643627	642350	
IO-360-D	653138	652047	649785	639200	634479
IO-360-DB	653129	652014	643627	642350	
IO-360-ES	653129				
IO-360-G	653139	652048	639786		
IO-360-GB	653129	652014	643627	642350	
IO-360-H	653139	652048	639786		
IO-360-HB	653129	652014	643627	642350	
IO-360-J	653139	652048	639786		
IO-360-JB	653129	652014	643627	642350	
IO-360-K	653139	652048	639786		
IO-360-KB	653129	652014	643627	642350	
IO-470-C	652011	652006	633256	626784	
IO-470-D	649133	630927	627530		
IO-470-E	649133	630927	627530		
IO-470-F	649133	630927	627530		
IO-470-G	649133	630927	627530		
IO-470-H	652011	652008	628995	630977	627348



Table 10-29. Crankshaft Assembly Part Number History

Specification	Crankshaft Assembly	Supersedes	Supersedes	Supersedes	Supersedes
IO-470-J	652009	643089	633246	628358	
IO-470-K	652009	643089	633246	628358	
IO-470-L	652010	643090	630886	628694	
IO-470-M	649133	630927	627530		
IO-470-N	652011	652006	643091	630932	629309
IO-470-P	629882				
IO-470-R	630977	629366			
IO-470-S	649133	630927	627530		
IO-470-U	649135	632195			
IO-470-V	649135	632195			
IO-520-A	649134	631716			
IO-520-B	649895	633620			
IO-520-BA	649896	639243			
IO-520-BB	649898	646438	642396		
IO-520-C	649895	633620			
IO-520-CB	649898	646438	642396		
IO-520-D	649134	631716			
IO-520-E	649134	631716			
IO-520-F	649134	631716			
IO-520-J	649134	631716			
IO-520-K	649134	631716			
IO-520-L	649134	631716			
IO-520-M	649895	633620			
IO-520-MB	649898	646438	642396		
IO-520-P	649144-1				
IO-550-A	649900	646604			
IO-550-B	649900	646604			
IO-550-C	649900	646604			
IO-550-D	646623				
IO-550-E	646623				
IO-550-F	646623				
IO-550-G	649900				
IO-550-L	646623				
IO-550-N	649900				
IO-550-P	649900				
IO-550-R	649900				
IOF-550-N	649900				
IOF-550-P	649900				
IOF-550-R	649900				



Non-Overhaul Repair and Replacement

Table 10-29. Crankshaft Assembly Part Number History

Specification	Crankshaft Assembly	Supersedes	Supersedes	Supersedes	Supersedes
LTSIO-360-E	653137	652045	641382		
LTSIO-360-EB	653136	652015	643633		
LTSIO-360-KB	653136	652015	643633		
LTSIO-360-RB	653136				
LTSIO-520-AE	649144-2	643126-1			
TSIO-360-A	653138	652047	649785	639200	634479
TSIO-360-AB	653129	652014	643627	642350	
TSIO-360-B	653138	652047	649785	639200	634479
TSIO-360-C	653139	652048	639786		
TSIO-360-CB	653129	652014	643627	642350	
TSIO-360-D	653139	652048	639786		
TSIO-360-DB	653129	652014	643627	642350	
TSIO-360-E	653139	652048	639786		
TSIO-360-EB	653129	652015	643633	642376	
TSIO-360-F	653139	652048	639786		
TSIO-360-FB	653129	652014	643627	642350	
TSIO-360-G	653139	652048	639786		
TSIO-360-GB	653129	652014	643627	642350	
TSIO-360-H	653139	652048	639786		
TSIO-360-HB	653129	652014	643627	642350	
TSIO-360-JB	653129	652014	643627	642350	
TSIO-360-KB	653129	652015	643633	642376	
TSIO-360-LB	653129	652014	643627	642350	
TSIO-360-MB	653129	652014	643627		
TSIO-360-RB	653129				
TSIO-360-SB	653129				
TSIO-470-B	652011	652008	628995		
TSIO-470-C	652011	652008	628995		
TSIO-470-D	652348	652007	632494		
TSIO-520-AE	649144-1	643126			
TSIO-520-AF	649134	631716			
TSIO-520-B	649895	633620			
TSIO-520-BB	649898	646438	642396		
TSIO-520-BE	649898	646438	642396		
TSIO-520-C	649134	631716			
TSIO-520-CE	649148	646683			
TSIO-520-D	649895	633620			
TSIO-520-E	649895	633620			
TSIO-520-EB	649898	646438	642396		



Table 10-29. Crankshaft Assembly Part Number History

Specification	Crankshaft Assembly	Supersedes	Supersedes	Supersedes	Supersedes
TSIO-520-G	649134	631716			
TSIO-520-H	649134	631716			
TSIO-520-J	649895	633620			
TSIO-520-T	649134	631716			
TSIO-520-UB	649898	646438	642396		
TSIO-520-VB	649898	646438	642396		
TSIO-520-WB	649898	646438	642396		
TSIO-550-A	649900				
TSIO-550-B	649900				
TSIO-550-C	649900				
TSIO-550-E	649900				
TSIO-550-G	649900				
TSIO-550-K	649900				
TSIO-550-N	649900				
TSIOF-550-D	649900				
TSIOF-550-J	649900				
TSIOF-550-K	649900				
TSIOL-550-A	652359				
TSIOL-550-B	652359				
TSIOL-550-C	652359				

1. Part No. 653382 Crankshaft, Part No. 656081 Gear and four each Part No. 654584 bolts must be used together
2. Part No. 653382 Crankshaft, Part No. 630690 Gear and four each Part No. 654584 bolts must be used together
3. Not a production engine



Non-Overhaul Repair and Replacement

Table 10-30. Crankshaft Assemblies

C/S Assy	Hanger Blade Bushing 1	BUSH I.D.	CWT Qty	C/S CWT	CWT Bushing	BUSH I.D.	Cheek LOC.	CWT. PIN	PIN DIA.	CWT. ORDER	RET Plate	RET RING
530860	531015	<u>.4613</u> .4643	1	531017	531016	<u>.4613</u> .4643	2	630261-15 ²	<u>.3758</u> .3768	5	530868	402805-3
	530863	<u>.435</u> .438	1	530864	530866	<u>.435</u> .438	2		<u>.3758</u> .3768	6		
531113	531015	<u>.4613</u> .4643	1	531017	531016	<u>.4613</u> .4643	2	630261-15 ²	<u>.3758</u> .3768	5	530868	402805-3
	530863	<u>.435</u> .438	1	530864	530866	<u>.435</u> .438	2		<u>.3758</u> .3768	6		
627822	626566	<u>.732</u> .739	2	627821	626564	<u>.732</u> .739	2	632261-11 ²	<u>.491</u> .492	3	633976	629004
			2				5			3		
			2				8			3		
628124	531015	<u>.4613</u> .4643	1	531017	531016	<u>.4613</u> .4643	2	630261-15 ²	<u>.3758</u> .3768	5	530868	402805-3
	530863	<u>.435</u> .438	1	530864	530866	<u>.435</u> .438	2		<u>.3758</u> .3768	6		
646623	350998	<u>.622</u> .626	2	639195	639193	<u>.622</u> .626	2	643626-105	<u>.565</u> .566	6	643629	629104
			1	639196			5	643626-103	<u>.474</u> .475	4		
			1	639196			5	643626-104	<u>.527</u> .528	5		
649133	350998	<u>.622</u> .626	2	639195	639193	<u>.622</u> .626	2	643626-101	<u>.556</u> .557	6	643629	629104
			2				5		6			
649134	350998	<u>.622</u> .626	2	639195	639193	<u>.622</u> .626	2	643626-101	<u>.556</u> .557	6	643629	629104
			1	639196			5	643626-103	<u>.474</u> .475	4		
			1	639196			5	643626-104	<u>.527</u> .528	5		
639135	350998	<u>.622</u> .626	2	639195	639193	<u>.622</u> .626	2	643626-101	<u>.556</u> .557	6	643629	629104
			1	639196			5	643626-104	<u>.527</u> .528	5		
			1	639196			5	643626-106	<u>.507</u> .508	4.5		
649138	350998	<u>.622</u> .626	2	639195	639193	<u>.622</u> .626	2	643626-101	<u>.556</u> .557	6	643629	629104
			1	639195			5	643626-104	<u>.527</u> .528	5		
			1	639195			5	643626-106	<u>.507</u> .508	4.5		
649141	350998	<u>.622</u> .626	1	639195	639193	<u>.622</u> .626	2	643626-101	<u>.556</u> .557	6	643629	629104
			1				2	643626-104	<u>.527</u> .528	5		



Table 10-30. Crankshaft Assemblies

C/S Assy	Hanger Blade Bushing 1	BUSH I.D.	CWT Qty	C/S CWT	CWT Bushing	BUSH I.D.	Cheek LOC.	CWT. PIN	PIN DIA.	CWT. ORDER	RET Plate	RET RING
649144-1	350998	$\frac{.622}{.626}$	1	639195	639193	$\frac{.622}{.626}$	2	643626-104	$\frac{.527}{.528}$	5	643629	629104
			1				2	643626-105	$\frac{.565}{.566}$	6		
649144-2	350998	$\frac{.622}{.626}$	1	639195	639193	$\frac{.622}{.626}$	2	643626-104	$\frac{.527}{.528}$	5	643629	629104
			1				2	643626-105	$\frac{.565}{.566}$	6		
639148	350998	$\frac{.622}{.626}$	2	639195	639193	$\frac{.622}{.626}$	2	643626-105	$\frac{.565}{.566}$	6	643629	629104
			1	639196			5	643626-103	$\frac{.474}{.475}$	4		
			1	639196			5	643626-104	$\frac{.527}{.528}$	5		
649895	350998	$\frac{.622}{.626}$	2	639195	639193	$\frac{.622}{.626}$	2	643626-101	$\frac{.556}{.557}$	6	643629	629104
			1	639196			5	643626-103	$\frac{.474}{.475}$	4		
			1	639196			5	643626-104	$\frac{.527}{.528}$	5		
649896	350998	$\frac{.622}{.626}$	2	639195	639193	$\frac{.622}{.626}$	2	643626-101	$\frac{.556}{.557}$	6	643629	629104
			1	639196			5	643626-101	$\frac{.556}{.557}$	6		
			1	639196			5	643626-103	$\frac{.474}{.475}$	4		
649898	350998	$\frac{.622}{.626}$	2	639195	639193	$\frac{.622}{.626}$	2	643626-105	$\frac{.565}{.566}$	6	643629	629104
			1	639196			5	643626-103	$\frac{.474}{.475}$	4		
			1	639196			5	643626-104	$\frac{.527}{.528}$	5		
649900	350998	$\frac{.622}{.626}$	2	639195	639193	$\frac{.622}{.626}$	2	643626-105	$\frac{.565}{.566}$	6	643629	629104
			1	639196			5	643626-103	$\frac{.474}{.475}$	4		
			1	639196			5	643626-104	$\frac{.527}{.528}$	5		
652005	350998	$\frac{.622}{.626}$	1	639197	639193	$\frac{.622}{.626}$	2	643626-105	$\frac{.565}{.566}$	6	643629	629104
			1	639197			2	643626-108	$\frac{.594}{.595}$	4		
652009	350998	$\frac{.622}{.626}$	1	639195	639193	$\frac{.622}{.626}$	2	643626-101	$\frac{.556}{.557}$	6	643629	629104
			1	639195			2	643626-104	$\frac{.527}{.528}$	5		



Non-Overhaul Repair and Replacement

Table 10-30. Crankshaft Assemblies

C/S Assy	Hanger Blade Bushing 1	BUSH I.D.	CWT Qty	C/S CWT	CWT Bushing	BUSH I.D.	Cheek LOC.	CWT. PIN	PIN DIA.	CWT. ORDER	RET Plate	RET RING
652010	350998	<u>.622</u> .626	2	639195	639193	<u>.622</u> .626	2	643626-101	<u>.556</u> .557	6	643629	629104
			2	639195			5	643626-104	<u>.527</u> .528	5		
652011	350998	<u>.622</u> .626	2	639195	639193	<u>.622</u> .626	2	643626-101	<u>.556</u> .557	6	643629	629104
			2	639195			5	643626-101	<u>.556</u> .557	6		
652039	350998	<u>.622</u> .626	2	639195	639193	<u>.622</u> .626	2	643626-101	<u>.556</u> .557	6	643629	629104
			2	639195			5	643626-101	<u>.556</u> .557	6		
652348	350998	<u>.622</u> .626	2	639195	639193	<u>.622</u> .626	2	643626-101	<u>.565</u> .566	6	643629	629104
			1	639196			5	643626-103	<u>.474</u> .475	4		
			1	639196			5	643626-104	<u>.527</u> .528	5		
652359	350998	<u>.622</u> .626	2	639195	639193	<u>.622</u> .626	2	643626-105	<u>.565</u> .566	6	643629	629104
			1	639196			5	643626-103	<u>.474</u> .475	4		
			1	639196			5	643626-106	<u>.507</u> .508	4.5		
653020	658975	<u>.754</u> .757	2	652833	628978	<u>.754</u> .757	2	643626-104	<u>.527</u> .528	3	631808	629004
			2				5	643626-104	<u>.527</u> .528	3		
			2				8	643626-104	<u>.527</u> .528	3		
653129	639580	<u>.604</u> .607	1	639199	639198	<u>.604</u> .607	2	643626-110	<u>.498</u> .499	4.5	653143	629004
			1	639199			2	643626-111	<u>.552</u> .553	6		
653136	639580	<u>.604</u> .607	1	639199	639198	<u>.604</u> .607	2	643626-110	<u>.498</u> .499	4.5	653143	629004
			1	639199			2	643626-111	<u>.552</u> .553	6		
653137	639580	<u>.604</u> .607	1	639199	639198	<u>.604</u> .607	2	643626-110	<u>.498</u> .499	4.5	653143	629004
			1	639199			2	643626-111	<u>.552</u> .553	6		
653138	639580	<u>.604</u> .607	1	639199	639198	<u>.604</u> .607	2	643626-109	<u>.545</u> .546	6	653143	629004
			1	639199			2	643626-109	<u>.545</u> .546	6		



Table 10-30. Crankshaft Assemblies

C/S Assy	Hanger Blade Bushing ¹	BUSH I.D.	CWT Qty	C/S CWT	CWT Bushing	BUSH I.D.	Cheek LOC.	CWT. PIN	PIN DIA.	CWT. ORDER	RET Plate	RET RING
653139	639580	<u>.604</u> .607	1	639199	639198	<u>.604</u> .607	2	643626-110	<u>.498</u> .499	4.5	653143	629004
			1	639199			2	643626-111	<u>.552</u> .553	6		
653382	639580	<u>.604</u> .607	1	639199	639198	<u>.604</u> .607	2	643626-112	<u>.520</u> .521	5	653143	629004
			1	639199			2	643626-112	<u>.520</u> .521	5		
653697	350998	<u>.622</u> .626	2	639195	639193	<u>.622</u> .626	2	643626-105	<u>.565</u> .566	6	643629	629104
			2	639195			5	643626-105	<u>.565</u> .566	6		
652800A1 ₃	628975	<u>.754</u> .757	2	652833	628978	<u>.754</u> .757	2	643626-104	<u>.527</u> .528	3	631808	629004
			2				5	643626-104	<u>.527</u> .528	3		
			2				8	643626-104	<u>.527</u> .528	3		
654359 ₃	350998	<u>.622</u> .626	1	639195	639193	<u>.622</u> .626	2	643626-105	<u>.565</u> .566	6	643629	629104
			1	639195			2	643626-105	<u>.565</u> .566	6		

1. Replacement Crankshaft hanger blade bushings may be purchased in standard and oversize dimensions as listed in Table 10-31
2. If replacing Part No. 630261 pin with Part No. 643626 pin, the Part No. 643629 plate must be used
3. Used in non-production engines only

Table 10-31. Crankshaft Hanger Blade Bushing Sizes

Crankshaft Blade Bushing Part No.	STANDARD	P 0.0015	P 0.003	P 0.005	P 0.010	P 0.015
350998	AVAILABLE	AVAILABLE	AVAILABLE	AVAILABLE	AVAILABLE	AVAILABLE
530863	AVAILABLE	N/A	AVAILABLE	AVAILABLE	N/A	N/A
531015	AVAILABLE	N/A	N/A	N/A	N/A	N/A
537038	AVAILABLE	N/A	N/A	N/A	N/A	N/A
626566	AVAILABLE	N/A	N/A	AVAILABLE	N/A	N/A
628975	AVAILABLE	N/A	AVAILABLE	AVAILABLE	AVAILABLE	N/A
639580	AVAILABLE	AVAILABLE	AVAILABLE	AVAILABLE	AVAILABLE	AVAILABLE



Non-Overhaul Repair and Replacement

**Table 10-32. Wide Rod Crankshaft
(NOT CURRENT PRODUCTION)**

C/S Assy	Hanger Blade Bushing	BUSH I.D.	CWT Qty	C/S CWT 1	CWT Bushing 2	BUSH I.D.	Cheek LOC.	CWT. PIN 3	PIN DIA.	CWT. ORDER	RET PLATE 4	RET RING 5
352174 (E-185-1, 3, 8, 9, 11)	350996	<u>.622</u> .626	2	352117	350977	<u>.622</u> .626	2	630261-4	<u>.5554</u> .5574	6	352115	352116
537661 (E-185-1, 3, 8, 9, 11 & E-225-4, 8)	350998	<u>.622</u> .626	1	352117	350997	<u>.622</u> .626	2	630261-4	<u>.5554</u> .5574	6	352115	352116
	537038	<u>.6534</u> .6554	1	537049	537044	<u>.6534</u> .6554	2	630261-4	<u>.5554</u> .5574	5	352115	352116
537290 (O-470-A, C, E, F, J & R)	350998	<u>.622</u> .626	1	352117	350997	<u>.622</u> .626	2	630261-4	<u>.5554</u> .5574	6	352115	352116
	537038	<u>.6534</u> .6554	1	537049	537044	<u>.6534</u> .6554	2	630261-4	<u>.5554</u> .5574	5	352115	352116
539576 (O-470-B & N)	350998	<u>.622</u> .626	1	352117	350997	<u>.622</u> .626	2	630261-2	<u>.5652</u> .5662	6	352115	352116
	537038	<u>.6534</u> .6554	1	537049	537044	<u>.6534</u> .6554	2	630261-1	<u>.5947</u> .5967	6	352115	352116
627576 (O-470-G)	350998	<u>.622</u> .626	1	352117	350997	<u>.622</u> .626	2	630261-5	<u>.5931</u> .5951	9	352115	352116
	537038	<u>.6534</u> .6554	1	625818	625817	<u>.6483</u> .6523	2	630261-5	<u>.5931</u> .5951	6	352115	352116
539665 (O-470-K, L, M)	350998	<u>.622</u> .626	2	352117	350997	<u>.622</u> .626	2	630261-4	<u>.5554</u> .5574	6	352115	352116
	350998	<u>.622</u> .626	2	352117	350997	<u>.622</u> .626	5	630261-4	<u>.5554</u> .5574	6	352115	352116
627587 (O-470-P)	350998	<u>.622</u> .626	2	352117	350997	<u>.622</u> .626	2	630261-4	<u>.5554</u> .5574	6	352115	352116
	350998	<u>.622</u> .626	2	352117	350997	<u>.622</u> .626	5	630261-4	<u>.5554</u> .5574	6	352115	352116
626784 (IO-470-C)	350998	<u>.622</u> .626	2	352117	350997	<u>.622</u> .626	2	630261-4	<u>.5554</u> .5574	6	352115	352116
	350998	<u>.622</u> .626	2	352117	350997	<u>.622</u> .626	5	630261-4	<u>.5554</u> .5574	6	352115	352116
627530 (IO-470-D, E, F, G, M & S)	350998	<u>.622</u> .626	2	352117	350997	<u>.622</u> .626	2	630261-4	<u>.5554</u> .5574	6	352115	352116
	350998	<u>.622</u> .626	2	352117	350997	<u>.622</u> .626	5	630261-4	<u>.5554</u> .5574	6	352115	352116
627348 (IO-470-H)	350998	<u>.622</u> .626	2	352117	350997	<u>.622</u> .626	2	630261-4	<u>.5554</u> .5574	6	352115	352116
	350998	<u>.622</u> .626	2	352117	350997	<u>.622</u> .626	5	630261-4	<u>.5554</u> .5574	6	352115	352116
629366 (IO-470-R)	350998	<u>.622</u> .626	2	352117	350997	<u>.622</u> .626	2	630261-4	<u>.5554</u> .5574	6	352115	352116
	350998	<u>.622</u> .626	2	352117	350997	<u>.622</u> .626	5	630261-4	<u>.5554</u> .5574	6	352115	352116



**Table 10-32. Wide Rod Crankshaft
(NOT CURRENT PRODUCTION)**

C/S Assy	Hanger Blade Bushing	BUSH I.D.	CWT Qty	C/S CWT ₁	CWT Bushing ₂	BUSH I.D.	Cheek LOC.	CWT. PIN ₃	PIN DIA.	CWT. ORDER	RET PLATE ₄	RET RING ₅
629882 (IO-470-P, T)	350998	$\frac{.622}{.626}$	1	352117	350997	$\frac{.622}{.626}$	2	630261-2	$\frac{.5554}{.5574}$	6	352115	352116
	350998	$\frac{.622}{.626}$	1	352117	350997	$\frac{.622}{.626}$	2	630261-2	$\frac{.5554}{.5574}$	6	352115	352116
628358 (IO-470-J, K)	350998	$\frac{.622}{.626}$	1	352117	350997	$\frac{.622}{.626}$	2	630261-4	$\frac{.5554}{.5574}$	6	352115	352116
	537038	$\frac{.6534}{.6554}$	1	537049	537044	$\frac{.6534}{.6554}$	2	630261-4	$\frac{.5554}{.5574}$	5	352115	352116
628694 (IO-470-L)	350998	$\frac{.622}{.626}$	2	352117	350997	$\frac{.622}{.626}$	2	630261-4	$\frac{.5554}{.5574}$	6	352115	352116
	350998	$\frac{.6534}{.6554}$	2	352117	350997	$\frac{.6534}{.6554}$	5	630261-3	$\frac{.527}{.528}$	5	352115	352116
629309 (IO-470-N)	350998	$\frac{.622}{.626}$	2	352117	350997	$\frac{.622}{.626}$	2	630261-4	$\frac{.5554}{.5574}$	6	352115	352116
	350998	$\frac{.6534}{.6554}$	2	352117	350997	$\frac{.6534}{.6554}$	5	630261-4	$\frac{.5554}{.5574}$	6	352115	352116
632195 (IO-470-U & V)	350998	$\frac{.622}{.626}$	2	352117	350997	$\frac{.622}{.626}$	2	630261-4	$\frac{.622}{.626}$	6	352115	352116
	350998	$\frac{.622}{.626}$	1	631968	350997	$\frac{.622}{.626}$	5	630261-3	$\frac{.622}{.626}$	5		
	350998	$\frac{.622}{.626}$	1	631968	350997	$\frac{.622}{.626}$	5	630261-32	$\frac{.622}{.626}$	4.5		

- Counterweight Part No. 352117 superseded by Part No. 639195;
Counterweight Part No. 537049 superseded by Part No. 639205;
Counterweight Part No. 639205 superseded by Part No. 639205A1;
Counterweight Part No. 625818 superseded by Part No. 639210;
Counterweight Part No. 639210 superseded by Part No. 639210A1
- Bushing Part No. 350997 superseded by Part No. 639193;
Bushing Part No. 537044 superseded by Part No. 639204
- Counterweight Supersedure (See Table 10-33 for details):
When using Part No. 630261-x pins, Part No. 635623 retainer plates must be used
When using Part No. 643626-x pins, Part No. 643629 retainer plates must be used
- Plate Part No. 352115 superseded by Part No. 629105;
Plate Part No. 629105 superseded by Part No. 635623;
Plate Part No. 635623 superseded by Part No. 643629
- Retaining Ring Part No. 352116 superseded by Part No. 629104



Table 10-33. Counterweight Supersedure

Current Part No.	Pin Diameter	Superseded Part No.	Pin Diameter	Original Part No.	Pin Diameter
643626-101	0.556 - 0.557	630261-35	0.5559 - 0.5569	630261-4	0.554 - 0.5574
643626-103	0.474 - 0.475	630261-38	0.474 - 0.475	630261-27	0.474 - 0.475
643626-104	0.527 - 0.528	630261-37	0.527 - 0.528	630261-3	0.527 - 0.528
643626-105	0.565 - 0.566	630261-40	0.5652 - 0.5662	630261-2	0.5652 - 0.5662
643626-106	0.507 - 0.508	630261-39	0.507 - 0.508	630261-32	0.507 - 0.508
643626-107	0.490 - 0.491	630261-34	0.4902 - 0.4906	N/A	N/A
643626-108	0.594 - 0.595	630261-36	0.5931 - 0.5951	630261-5	0.5931 - 0.5951
643626-109	0.545 - 0.546	630261-41	0.545 - 0.546	N/A	N/A
643626-110	0.498 - 0.499	630261-43	0.498 - 0.499	N/A	N/A
643626-111	0.552 - 0.553	630261-44	0.552 - 0.553	N/A	N/A
643626-112	0.520 - 0.521	N/A	N/A	N/A	N/A
N/A	N/A	N/A	N/A	630261-11	0.4916 - 0.4921
N/A	N/A	N/A	N/A	630261-15	0.3758 - 0.3768
N/A	N/A	N/A	N/A	630261-17	0.6700 - 0.6710

10-9.1.1. Crankshaft Counterweight Removal

1. Remove the counterweight retaining rings (snap rings) from the counterweight bores using Inside snap ring pliers with a 90 degree bend.
2. Remove the counterweight pin retaining plates from the bores. The plates are a close tolerance fit and may require slight rocking to remove them.
3. Remove the counterweight pins with a magnet.

CAUTION: Retaining rings are single use; discard immediately upon removal.

4. Discard the retaining plates and retaining rings.



10-9.1.2. Counterweight Identification

Counterweights dimensions are illustrated in Figure 10-26 through Figure 10-34.

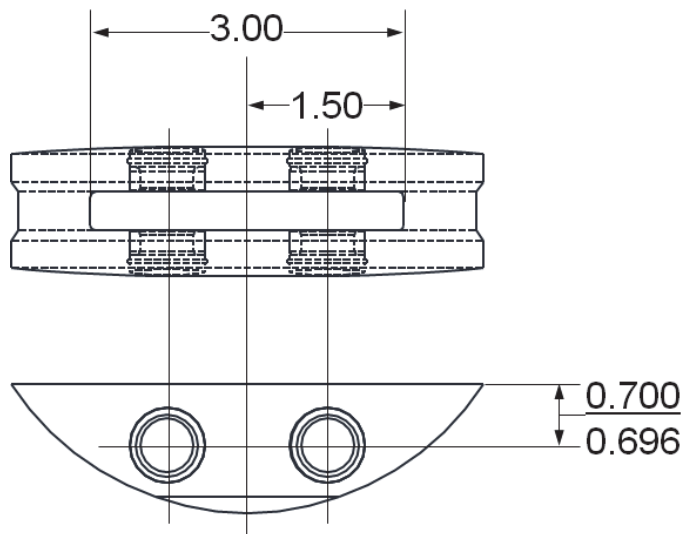

Figure 10-26. Part No. 530864 Counterweight Assembly
(made with 530865 Counterweight and 530866 Bushings)

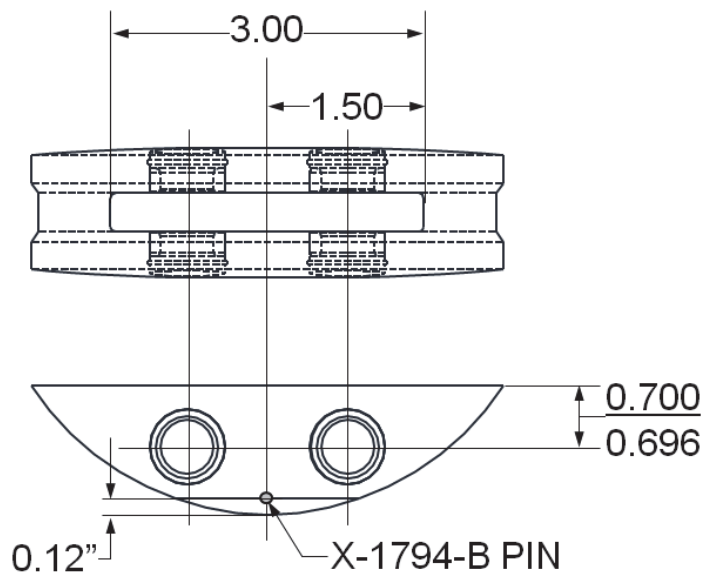

Figure 10-27. Part No. 531017 Counterweight Assembly
(made with 530865 Counterweight and 531016 Bushings)

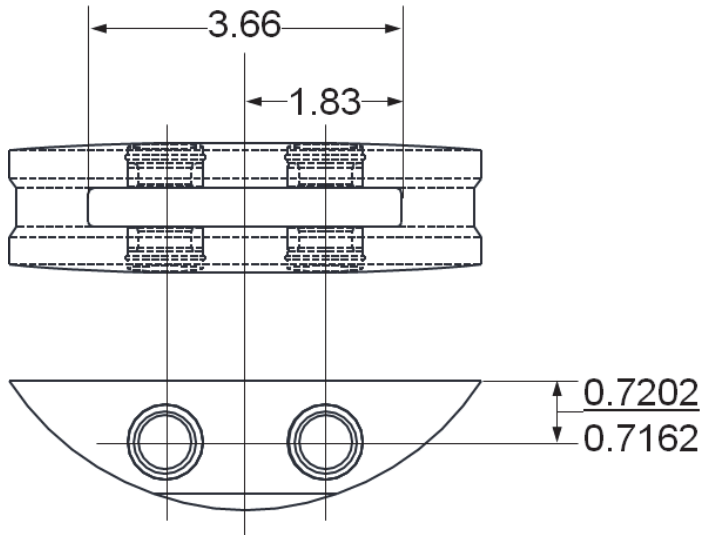

Figure 10-28. Part No. 639196 Counterweight Assembly
(made with 631903 Counterweight and 639193 Bushings)

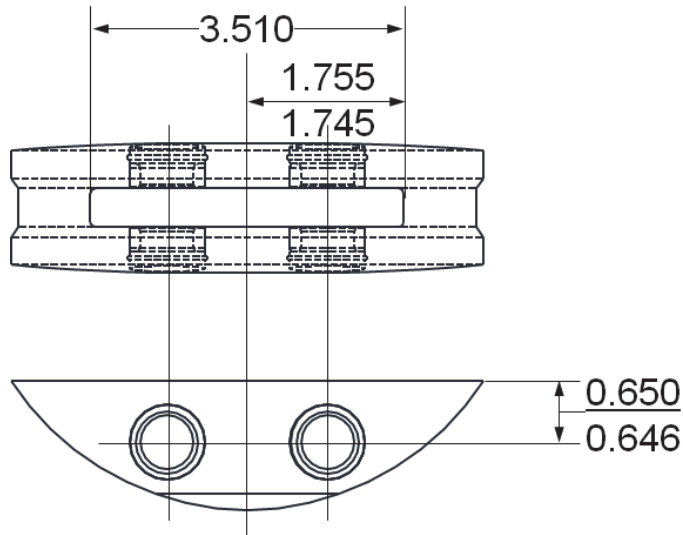

Figure 10-29. Part No. 639197 Counterweight Assembly
(made with 633339 Counterweight and 639193 Bushings)

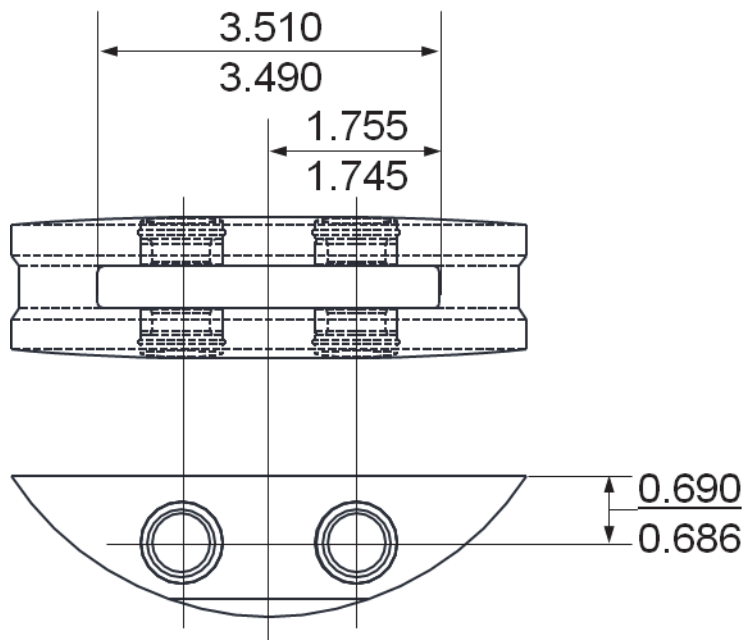

Figure 10-30. Part No. 639195 Counterweight Assembly
(made with 351000 Counterweight and 639193 Bushings)

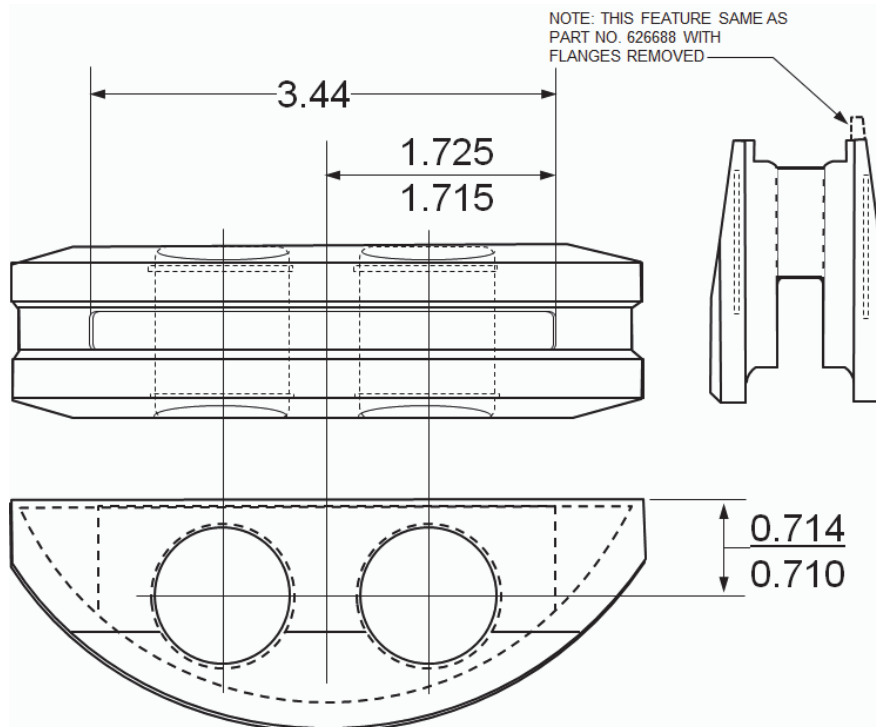

Figure 10-31. Part No. 639199 Counterweight Assembly
(made with 629693 Counterweight and 639198 Bushings)

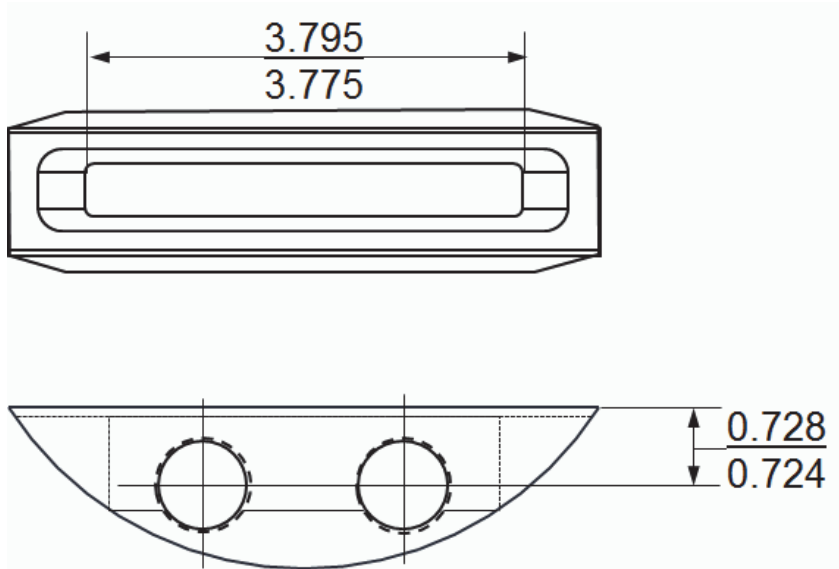

Figure 10-32. Part No. 652833 Counterweight Assembly
(made with 652834 Counterweight and 628978 Bushings)

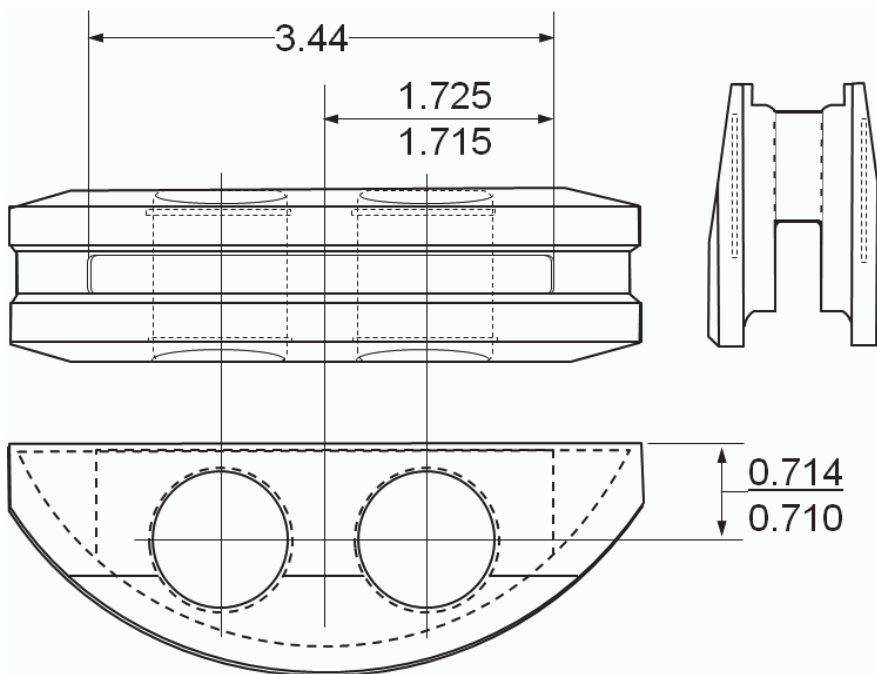

Figure 10-33. Part No. 627821 Counterweight Assembly
(made with 626688 Counterweight and 626564 Bushings)

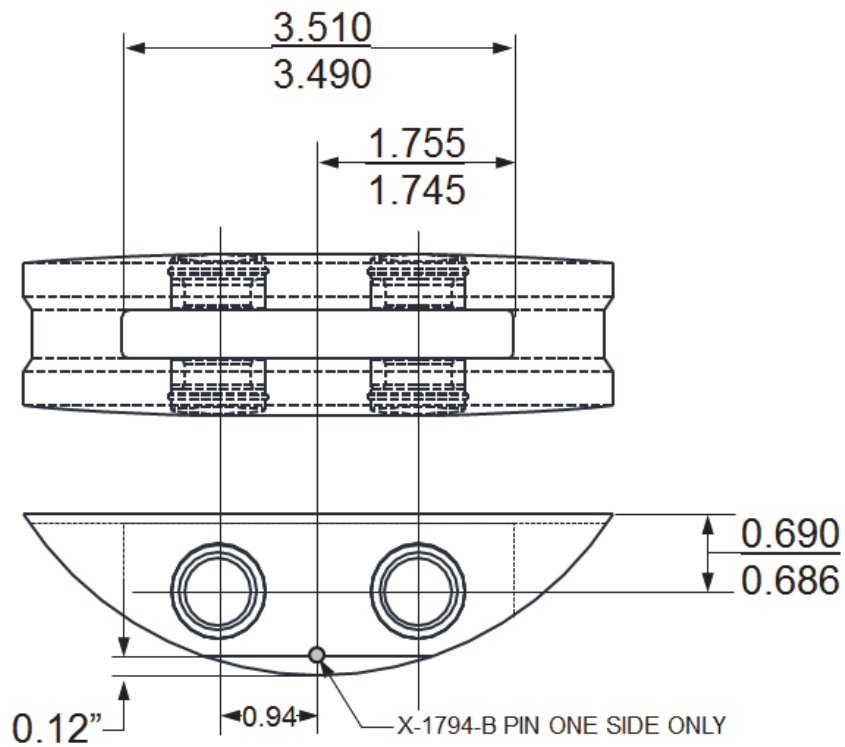

Figure 10-34. Part No. 639205 and 639210 Counterweight Assemblies
(made with 35100 Counterweight)
(639205 Counterweight uses 639204 Bushings)
(639210 Counterweight uses 639209 Bushings)



10-9.1.3. Crankshaft Counterweight Inspection

CAUTION: Only the case hardened (tuftrided) counterweight assemblies P/N 639195, 639196, 639197, 639199, 639205, or later design and 627821, 530864, 531017 (non-tuftrided) counterweight assemblies may be considered for bushing replacement. Discard all other earlier design counterweights.

CAUTION: On GTSIO-520 engine models, ALL Part No. 631810 counterweights must be replaced with 652833, or later design counterweights. Scrap all 631810 counterweights upon removal.

Equipment required

- 4% copper sulfate (CuSO_4) and water solution (by volume)
- Borroughs Part No. 8077C, Counterweight Bushing Removal/Installation Fixture (Section 2-1), or equivalent
- Two matched V-blocks
 1. Inspect the crankshaft counterweight bump surface as shown in Figure 10-35; bump surface contact marks must not exceed 0.005 inches in depth.
 2. Remove and discard the counterweight bushings using the Counterweight Bushing Removal/Installation Fixture 8077C or equivalent.
 3. Thoroughly clean the counterweight bushing bore.
 4. Verify tuftriding is present on the counterweight assemblies by placing one drop of a 4% copper sulfate (CuSO_4) and water solution (by volume) on the cleaned surface of the counterweight bushing bore.
 5. Allow at least 15 seconds for the chemical reaction to take place.
 6. Formation of red deposits indicates the absence of tuftriding. Discard any counterweight that does not exhibit tuftriding and replace with new counterweights.
 7. If no reaction occurs, wipe off copper sulfate and water solution. The counterweight may be reused during overhaul, provided it meets all other inspection criteria.
 8. Perform a “Magnetic Particle Inspection” on the crankshaft and counterweights according to the instructions in Section 11-3.

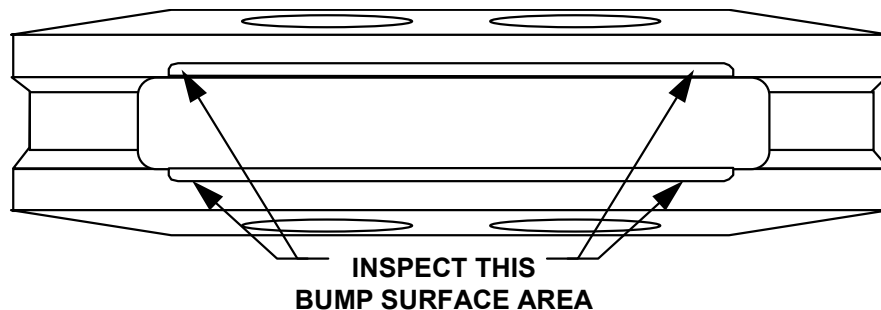

Figure 10-35. Crankshaft Counterweight Bump Service Inspection



10-9.1.4. Crankshaft Counterweight Bushing Bore Inspection

Equipment required

- Federal Dimension Air Gauge (with appropriate setting ring and air plug) or
 - Starrett No. 78 series 3-point contact inside micrometer (Section 2-1)
1. Verify the counterweight bushing bores are smooth. Discard counterweights with worn, pitted, fretted or out-of-round bushing bores.
 2. Use a Federal Dimension Air Gauge (with appropriate setting ring and air plug) or Starrett No. 78 series 3-point contact inside micrometer to measure the bushing bores. Compare the bushing bores specified total indicator reading (T.I.R.) to the specifications in Table 10-34. Discard counterweights with bushing bores exceeding the specified dimensions.
 3. Carefully inspect the counterweight counterbores for signs of wear in the wall that retains the counterweight pin retaining plates. This area is adjacent to the inside edge of the retaining ring groove. It may appear as an additional step and/or taper of the hole into the retaining ring groove. Discard any counterweight that is:
 - a. Cracked
 - b. Worn, pitted, fretted, or out of round bushing bores
 - c. Worn or has distortions in the retaining ring groove that can affect the retaining ring seating
 4. If no plate wear is evident, check the retaining ring groove in each hole for wear patterns that can affect the retaining ring seating. Any worn condition that may affect retaining ring seating will require replacement of the counterweight.
 5. Crankshaft counterweights are matched in pairs with a maximum weight variation of two grams. If either counterweight is damaged, replace the counterweights as a matched pair.

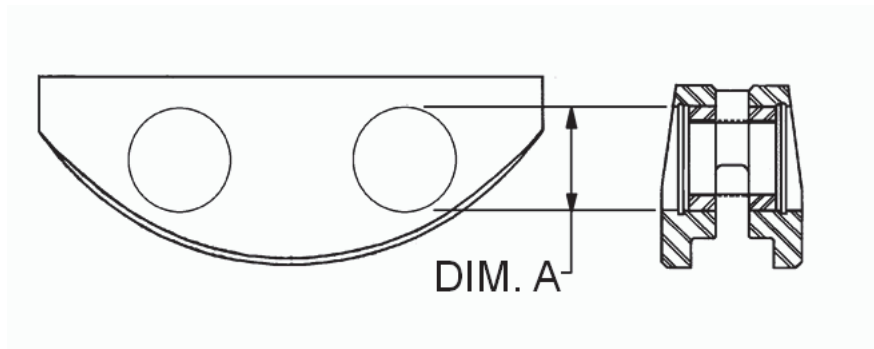

Figure 10-36. Counterweight Bushing Bore Inspection

Table 10-34. Counterweight Bushing Bore Dimensions

Counterweight Assembly Part No.	Counterweight Part No.	"A" Diameter See Figure 10-36
530864	530865	0.687 - 0.688
531017	530865	0.687 - 0.688
627821	626688	1.000 - 1.001
639195 639205 639210	351000	0.8745 - 0.8755
639196	631903	0.8745 - 0.8755
639197	633339	0.8745 - 0.8755
639199	629693	1.000 - 1.001
652833	652834	1.000 - 1.001



10-9.1.5. Crankshaft Counterweight Bushing Replacement

Replace all crankshaft counterweight bushings at overhaul:

Equipment Required

- Borroughs Part No. 8077C Counterweight Bushing Removal/Installation Fixture, or equivalent
- Federal Dimension Air Gauge (with appropriate setting ring and air plug) or
- Starrett No. 78 series 3 point contact inside micrometers
- Snap ring pliers (with 90-degree bend)
- Arbor press

The complete crankshaft /counterweight assembly is dynamically balanced and the counterweights are matched in pairs with a maximum weight variation of two grams. If either counterweight is damaged, both counterweights in the matched pair must be replaced as a pair on that crankshaft cheek, even if only one counterweight is unserviceable.

WARNING

Removing the counterweight bushings with makeshift tools may cause irreparable damage which could lead to engine malfunction.

1. Remove the crankshaft counterweight bushings with a Borroughs Part No. 8077C Counterweight Bushing Removal/Installation Fixture and an arbor press.
2. Measure the crankshaft counterweight bushing bore inside diameter. Bushing bores must be smooth and cylindrical (no out of round). Replacement bushings require an interference fit of 0.0015 to 0.003 inches in the bushing bores.
3. Visually inspect the counterweights to determine acceptability of parts. Replace counterweights with worn, pitted, fretted or out-of-round bushing bores.

WARNING

Counterweight bushings and bushing retainer plates (except as indicated in Figure 10-38) require an interference fit. Replace counterweight bushings (or counterweights) if insertion in the bushing bore is possible without resistance.

4. Inspect counterweight bores/counterbores for signs of wear in the wall that retains the counterweight pin retaining plates (area adjacent to the inside edge of the retaining groove; it may appear as a taper of the hole into the retaining ring groove). If any wear is evident, discard and replace the counterweight.

NOTE: Replace both counterweights in the matched pair even if only one counterweight is unacceptable.

5. If the counterweight conforms to specification, check the counterweight retaining ring groove for distortions in width, roundness or pattern which can affect the seating of the retaining ring. Discard and replace the counterweight matched pair if wear or distortions are found even on one counterweight.



Non-Overhaul Repair and Replacement

6. Install new bushings in the same positions as the old bushings on the counterweight assemblies (Figure 10-37) using the Borroughs Part No. 8077C Counterweight Bushing Removal/Installation Fixture. The bushing lead-in (Figure 10-37) must be positioned toward the counterweight during installation. Press the bushing flush with the surfaces as illustrated.

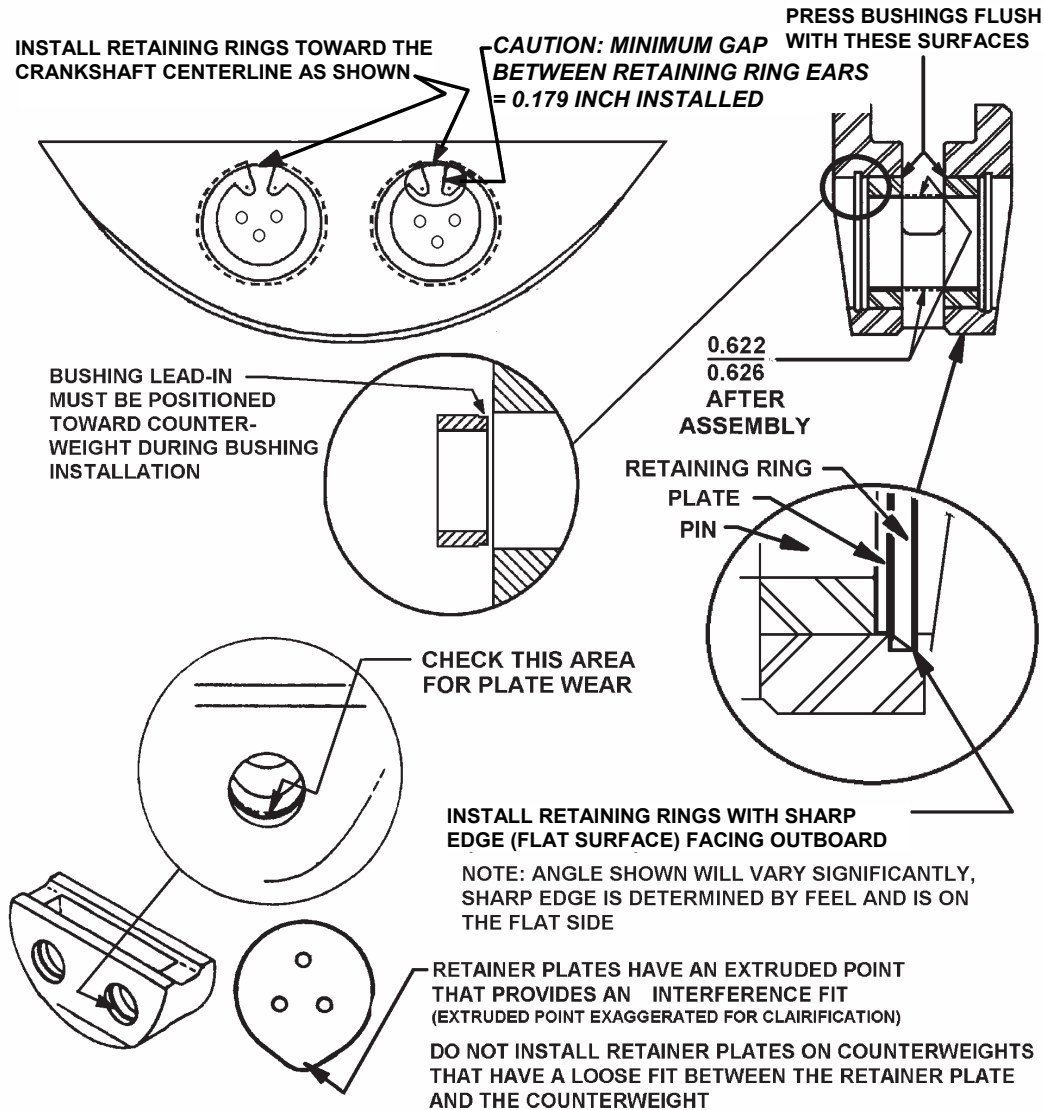

Figure 10-37. Counterweight Inspection, Repair and Installation

Applicable to 360, 470, IO520, LTSIO-520, and 550 Series Engines

Not Applicable to GTSIO-520 (See Figure 10-38)

7. Verify newly installed bushing dimensions in Table 10-35. Close tolerances require replacement bushings shall be 100% dimensionally inspected using calibrated, accurate measuring equipment (one of the following):
 - a. Federal Dimension Air Gauge (with appropriate setting ring and air plug)
 - b. Starrett No. 78 series 3 point contact inside micrometers.



8. Perform a “Magnetic Particle Inspection” according to the instructions in Section 11-3 on the crankshaft counterweight assembly to ensure the counterweight is free of cracks.

Table 10-35. Counterweight Bushing Bore Dimensions

Counterweight Assembly Part No.	“A” Diameter See Figure 10-37 & Figure 10-38
530864	0.435 - 0.438
531017	0.4613 - 0.4643
639195	0.622 - 0.626
639196	0.622 - 0.626
639197	0.622 - 0.626
639199	0.604 - 0.607
639205	0.6514 - 0.6554
639210	0.6483 - 0.6523
652833	0.754 - 0.757
627821	0.732 - 0.739

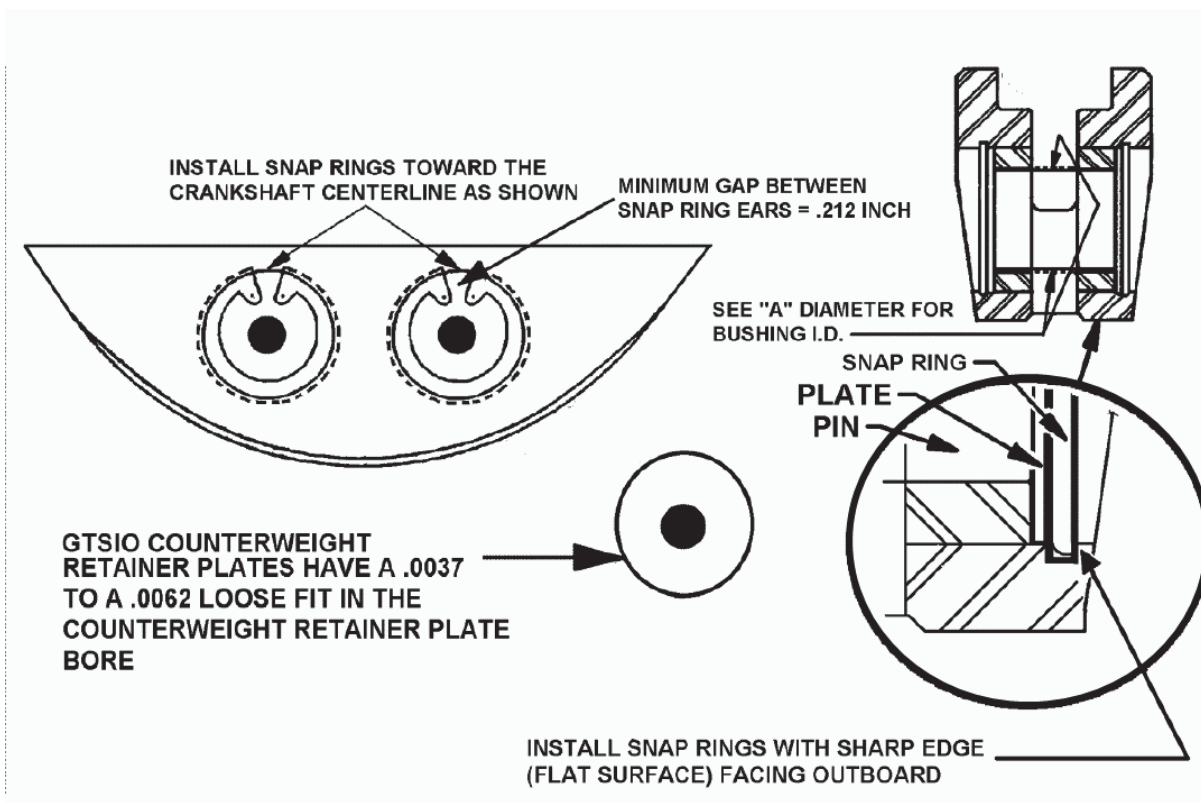

Figure 10-38. GTSIO-520 Counterweight Inspection, Repair and Installation



10-9.1.6. Crankshaft Hanger Blade Bushing Inspection

Crankshaft hanger blade bushings (also referred to as damper bushings) must meet dimensional specifications in Table 10-36. If the hanger blade bushing exhibits gouges or scratches, is loose, or is otherwise unserviceable, replace the hanger blade bushing:

Equipment Required

- Borroughs Part No. 8077A Crankshaft Hanger Blade Bushing Removal/Installation Tool, or equivalent
- Federal Dimension Air Gauge (with appropriate setting ring and air plug) or Starrett No. 78 series 3 point contact inside micrometers

WARNING

Removing or installing crankshaft counterweight bushings with makeshift tools may cause irreparable damage to the crankshaft that could lead to engine malfunction.

1. The bushing bores must be smooth and cylindrical (no out of round). Replacement bushings require an interference fit of 0.0015 to 0.003 inches in the bushing bores.
2. Install the new crankshaft hanger blade bushings per Figure 10-39 using the Borroughs Part No. 8077A Crankshaft Hanger Blade Bushing Removal/Installation Tool.

NOTE: New bushings must be installed into the same positions as the original. Replacement crankshaft hanger blade bushings are available in standard and some oversize dimensions.

3. Review Table 10-36 and Figure 10-39 to determine acceptability of parts.
4. Verify the dimensions of the newly installed bushings. Close tolerances require replacement bushings be 100% dimensionally inspected using calibrated, accurate measuring equipment (one of the following):
 - a. Federal Dimension Air Gauge (with appropriate setting ring and air plug)
 - b. Starrett No. 78 series 3 point contact inside micrometers.
5. Perform a “Magnetic Particle Inspection” according to the instructions in Section 11-3 on the crankshaft assembly after bushing installation to ensure no cracks developed as a result of bushing installation and the crankshaft is free of cracks.

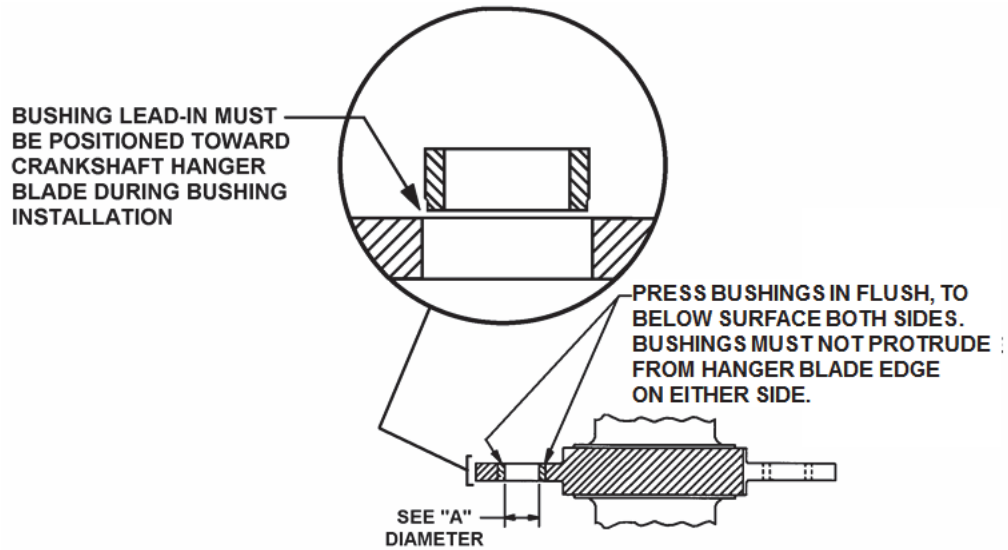

Figure 10-39. Crankshaft Hanger Blade Bushing Replacement

Table 10-36. Counterweight Hanger Blade Bushing Dimensions

Crankshaft Assembly Part No.	Crankshaft Part No.	Installed Diameter "A" See Figure 10-39	Crankshaft Assembly Part No.	Crankshaft Part No.	Installed Diameter "A" See Figure 10-39
530860	530789 ¹	0.4613 - 0.4643	652010	652004	0.622 - 0.626
646623	643687	0.622 - 0.626	652011	652004	0.622 - 0.626
649133	649132	0.622 - 0.626	652039	649137	0.622 - 0.626
649134	649132	0.622 - 0.626	652348	652004	0.622 - 0.626
649135	649132	0.622 - 0.626	652359	649899	0.622 - 0.626
649138	649137	0.622 - 0.626	653020	653019	0.754 - 0.756
649141	649137	0.622 - 0.626	653129	652012	0.604 - 0.607
649144-1	649143	0.622 - 0.626	653136	652013	0.604 - 0.607
649144-2	649146	0.622 - 0.626	653137	652044	0.604 - 0.607
649148	649147	0.622 - 0.626	653138	652046	0.604 - 0.607
649895	649894	0.622 - 0.626	653139	652046	0.604 - 0.607
649896	649894	0.622 - 0.626	653382	653383	0.604 - 0.607
649898	649897	0.622 - 0.626	653697	649137	0.622 - 0.756
649900	649899	0.622 - 0.626	652800	649474 ²	0.754 - 0.626
652005	652004	0.622 - 0.626	654359	643687	0.622 - 0.626
652009	652004	0.622 - 0.626			

Install flush to below surface unless otherwise specified.

1. Part No. 530789 installs flush to 0.015 - 0.005 below surface
2. Part No. 649474 installs flush to 0.005 below surface



Non-Overhaul Repair and Replacement

Intentionally Left Blank



10-9.2. Oil Control Plug Replacement

- Oil Plug Leak Test Fixture (Figure 2-12)
- Oil Control Plug Installation Tool (Figure 2-8 through Figure 2-11)
(differs by engine model)

NOTE: The 2.375-inch diameter collar at the rear of the Oil Control Plug Installation Tool prevents driving the oil control plug beyond the specified depth in the crankshaft. **Do not** use makeshift tools to install the oil control plug.

1. Remove the crankshaft oil control plug using a 0.4375-20 diameter bolt approximately 8 inches long with 0.4375 -20NF threads and a slide hammer.
2. Inspect the inside diameter of the crankshaft for rust or pitting. Discard crankshafts exhibiting rust or pitting. Clean the bore of the crankshaft using a pneumatic drill and a two inch Merrit Wheel. The inside diameter of the crankshaft must be clean and free of any sludge residue prior to installing a new oil control plug.
3. Two special tools (Oil Control Plug Installation Tool (Table 10-35) and Oil Control Plug Leak Test Fixture (Figure 2-12)) are required to perform this procedure. The tools are designed especially for this application. The 2.375-inch diameter collar at the rear of the Oil Control Plug Installation Tool prevents driving the oil control plug beyond the specified depth for the plug in the crankshaft (see Table 10-35).

Table 10-37. Crankshaft Oil Plug Installation Specifications

Engine Model	Installation Tool	Depth of Plug in Crankshaft
IO-360, LTSIO-360, TSIO-360	Figure 2-8	4.44 - 4.46 inches
O-470-G, IO-470-C, H, J, K, L & N	Figure 2-9	5.91 - 5.93 inches
O-470-B, E, M, R, S & U IO-470, D, F, M, S, U & V TSIO-470	Figure 2-11	4.96 - 4.98 inches
520 & 550 Sandcast	Figure 2-11	4.92 - 4.94 inches
520 & 550 Permold	Figure 2-10	4.66 - 4.68 inches

CAUTION: Do not use makeshift tools to perform this procedure. Non-conforming tools can damage components, rendering them unusable.

NOTE: Ensure the threaded hole in the oil control plug is facing toward the propeller flange at installation.

4. Carefully drive in the new oil control plug into the crankshaft using an air impact hammer and the Oil Control Plug Installation Tool.
5. Leak test the oil control plug and pressure test the crankshaft by connecting the Oil Control Plug Leak Test Fixture (Figure 2-12) to the crankshaft using a C-clamp with neoprene rubber pads as shown in Figure 10-40. Apply 70-80 psi air pressure and close the air supply. Monitor the pressure gauge for 15 seconds; allowable pressure loss is not to exceed 2 psi.

Non-Overhaul Repair and Replacement

6. After all crankshaft repairs have been completed, restore the helix pattern to the exposed portion of the crankshaft according to instructions in Section 10-9.3.

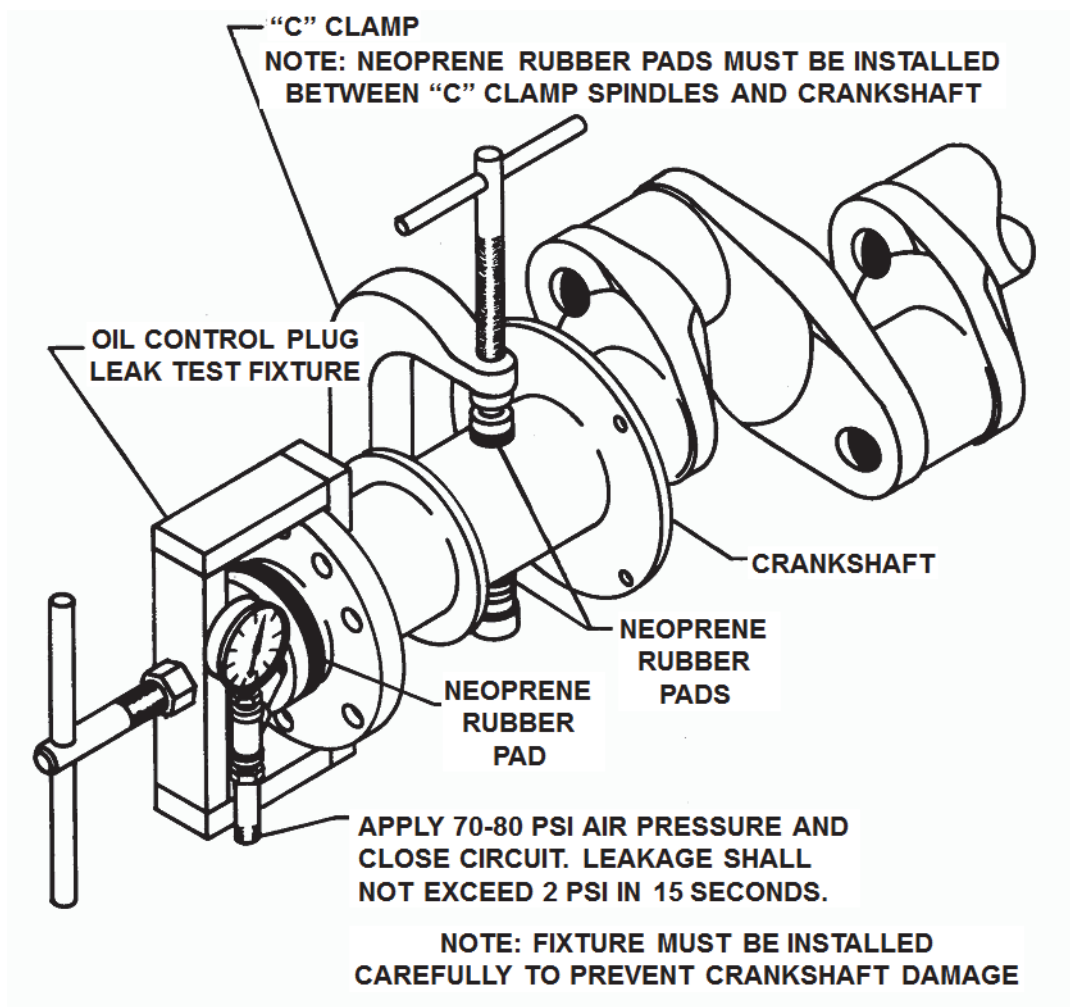

Figure 10-40. Crankshaft Oil Control Plug Leak Test



10-9.3. Crankshaft Plating Overhaul

1. Remove any tin plating on the crankshaft in the one inch area shown in Figure 10-41 by rubbing a piece of very fine emery cloth, buffing around the shaft to attain a smooth uniform finish without any scratches.
2. Apply a ½-inch wide strip of 180 grit emery cloth against the newly polished one inch area on the crankshaft with firm hand pressure to lightly scratch (not score or gouge) a new helix design in a 30° pattern in the plated area as shown in Figure 10-41. Rub the emery cloth in the plated area outward toward the propeller flange, counter-clockwise. For left-hand rotating engines, rub clockwise. The helix promotes proper seating of the crankshaft oil seal and a better seal to help prevent leakage.
3. After preparing the first quarter portion, rotate the crankshaft by hand so that the next portion is visible and continue rubbing with the 180 grit emery cloth until the entire one inch plated area (Figure 10-41) around the crankshaft is lightly scratched with the helical design.
4. Flush the particles from the crankshaft with mineral spirits.
5. Wipe the plated area with the lightly scratched helical pattern on the crankshaft with acetone. Ensure the crankshaft is free of any debris or particulate matter to facilitate clean sealing.

CAUTION: Avoid buildup of paint on the propeller flange. Excessive paint on the mating surfaces could negatively affect the mechanical clamping between the propeller and the crankshaft.

6. Mask the crankshaft except for the area prepared in the previous steps to prevent over spray. Apply a uniform coat of aluminum paint to the portion of the crankshaft which will be exposed to the elements. Allow the paint to dry to the touch.

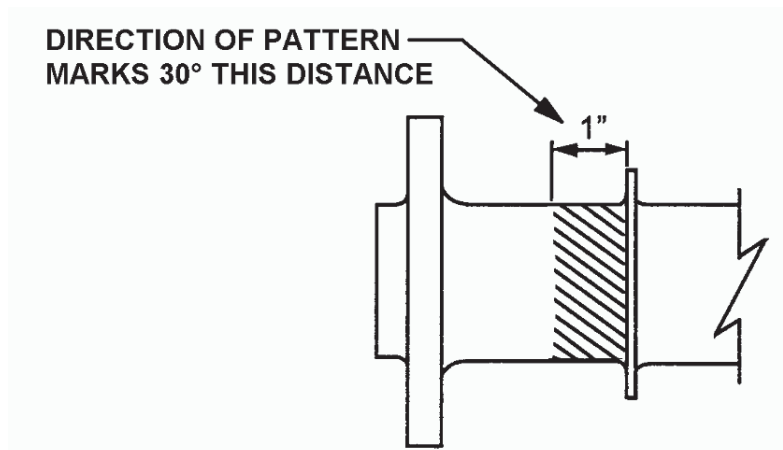

Figure 10-41. Crankshaft Helix Pattern



10-9.4. Connecting Rod Replacement

WARNING

Never remove material from a connecting rod. The removal of metal from connecting rods, crankshafts or pistons, for the purposes of balancing, is not an approved procedure. Removing material from a connecting rod will destroy the shot peen treatment and may cause stress risers. Connecting rods are matched to limit engine vibration with no more the 1/2 ounce weight variance allowed between connecting rods in opposing cylinder bays.

CAUTION: For dynamic balance, connecting rod assemblies are paired with a maximum weight variation of one-half ounce (14 grams) between opposing bays. For this reason, connecting rods must be replaced in pairs.

NOTE: The allowable weight variation between pistons and connecting rods does not apply to the entire set. Connecting rod and piston weight variations are limited to opposing bays.

1. Remove the connecting rods according to the instructions in the primary Instructions for Continued Airworthiness(Section 1-1.1).
2. Clean the connecting rods with an approved solvent or degreaser. Verify all surfaces are free of varnish, oil, or residue that will affect reliability of visual, dimensional and magnetic particle inspections.

10-9.4.1. Connecting Rod Dimensional Inspection

1. Verify the connecting rod and cap mate marks are aligned and the position numbers stamped on or adjacent to the bolt boss match. Scrap connecting rods and caps with mate marks that do not align.
2. Visually inspect the connecting rods for corrosion, pitting, discoloration (bluing), galling, bending, twisting, impact damage or nicks. Scrap connecting rods with any of these indications.
3. Weigh the connecting rods within opposing cylinder pairs (1 vs. 2, 3 vs. 4, etc.) with a calibrated scale, accurate to one-half ounce, and record the weight variation. Discard connecting rod pairs exceeding 1/2 ounce maximum weight variation.
4. Visually inspect the connecting rod and cap parting surface. Contact signatures resulting from assembly forces are normal and acceptable. Connecting rods exhibiting fretting signatures, indicated by erosion of the original machining marks, either locally or over the entire surface, are not acceptable for continued service. Scrap connecting rods with fretting at the parting surfaces; do not attempt rework.
5. Visually inspect the nut seat area. Excessive fretting signatures indicate material loss. Scrap connecting rods with edge loading under the bolt head surface contact area.



6. Visually inspect dowel surfaces at the rod and cap bolt holes. Scrap connecting rods with fretting at the dowel surface.
7. Align the mate marks on matching position numbers and assemble the connecting rod and cap by installing a bolt through the cap and rod. With the cap seated firmly against the rod, you must be able to install the remaining bolt using hand pressure only. Scrap connecting rods if the bolts cannot be installed by hand.
8. Lubricate the connecting rod bolt and nut threads with clean 50 weight aviation oil.
9. Install and torque the nuts and bolts to Appendix B specifications.
10. Inspect the inside diameter joint of the rod to cap with both bolts and nuts installed and torqued; mismatch (or a step) must be less than 0.001 inch. To check for a mismatch: place the rod on a surface plate with the split line at the 6 and 12 o'clock position; use V-blocks to hold the connecting rod in place. Use a dial indicator mounted on a height gauge, zero out on one side of the split line and move the indicator across the split line; a mismatch (or a step) of more than 0.001 inch is not acceptable.

WARNING

Removing and installing the piston pin bushing with makeshift tools will damage connecting rods.

11. Remove the piston pin bushings from the connecting rod using a Connecting Rod Bushing Removal/Installation Set (Borroughs Part No. 8098, or equivalent) and an arbor press.
12. Inspect the piston pin bushing bore and surrounding area for nicks, gouges and mechanical damage. Scrap connecting rods with any of these indications.
13. Use precision measuring equipment, such as a dial bore gauge or air gauge; verify the connecting rod meets the dimensional specifications in Figure 10-42 and Table 10-38.
14. Measure the inside diameter of the rod and cap within 30° of the rod and cap joint; take a second measurement 90° from the first. Both measurements must meet dimensional specifications in Figure 10-42 and Table 10-38; the difference between these two measurements is an indication of out-of-round and must not exceed 0.0015 inches. Scrap connecting rods and caps which fail to meet dimensional specifications in Figure 10-42 and Table 10-38 or exceed 0.0015" out-of-round. Scrap connecting rods and caps which fail to meet these specifications.
15. Inspect the connecting rod channel rails for nicks, gouges or mechanical damage. Scrap connecting rods with any of these indications.
16. Perform a "Connecting Rod Magnetic Particle Inspection" according to the instructions in Section 11-3.1.



WARNING

Failure to comply with the specifications and instructions depicted in Figure 10-42 will result in engine malfunction and/or stoppage.

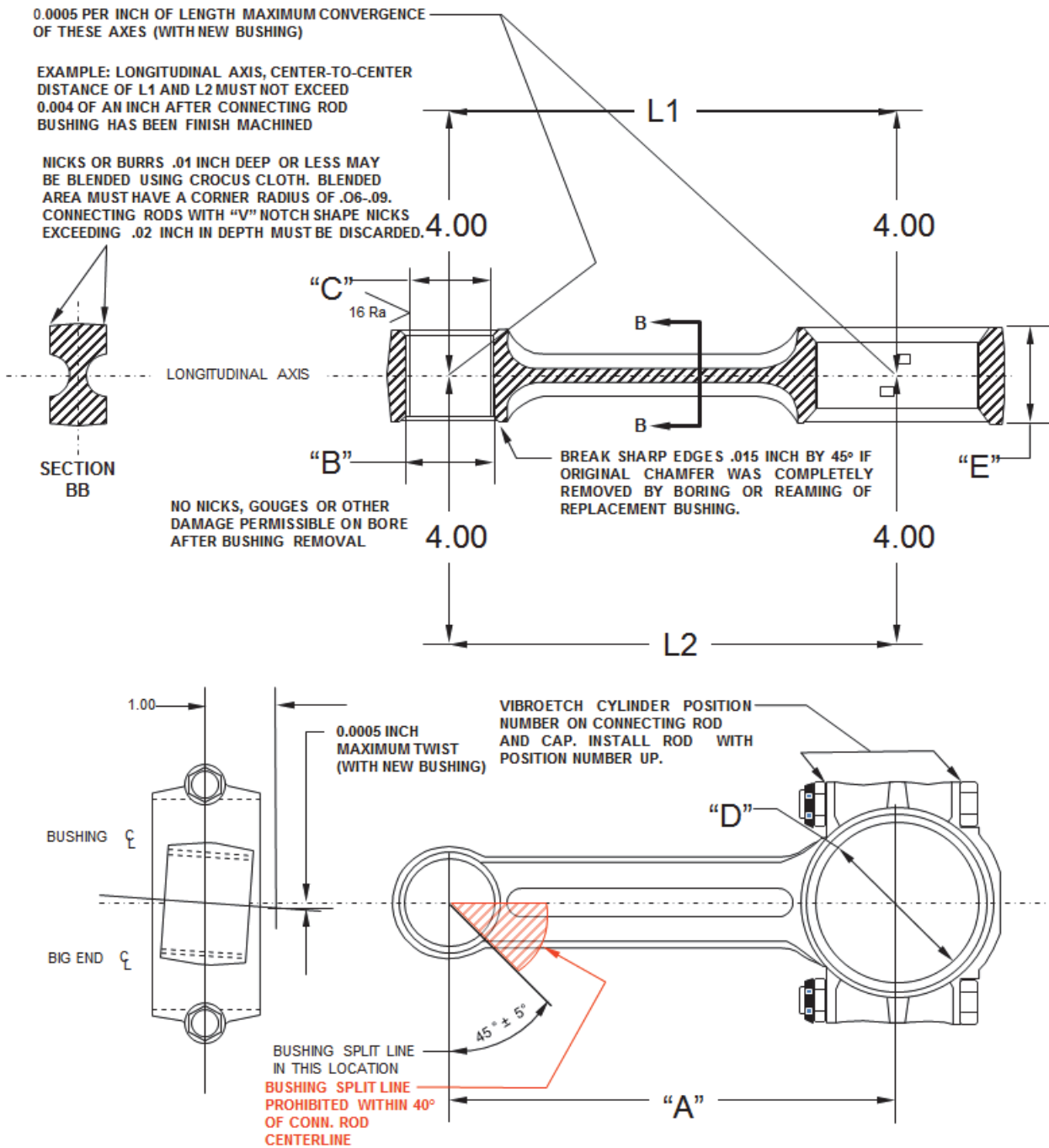

Figure 10-42. Connecting Rod Dimensions



Table 10-38. Connecting Rod Specifications

Engine Model	Connecting Rod Part Number	Forging Part Number	Nut P/N ^{1, 2} Bolt P/N	Connecting Rod Bores Centerline Distance "A"	Piston Pin Bore I.D. (No Bushing) "B"	Piston Pin Bushing I.D. Bushing P/N "C"	Crankpin Bore I.D. "D"	Connecting Rod End Width "E"
WARNING								
If the Hardware listed in the footnotes at the end of the Table is not available, replace the obsolete connecting rod assembly with replacement (later) configuration listed for the engine model.								
O/IO/TSIO-470 Small Bore IO & TSIO-520 IO-346	655910 ³ Superseded 655000 655004 654999 646778	646126 Superseded 632041	654490 Nut 655958 Bolt	6.6230 6.6270	1.2340 1.2350	1.1267 1.1269 530658	2.3755 2.3760	1.521 1.525
E- Series O-470-2,4,11,13A,15 IO-470-C,G,J,K,P,R	654796 ^{3, 4} Superseded 646478 A36121 ⁵	646126 Superseded 632041	654487 Nut 655960 Bolt	6.6230 6.6270	1.2340 1.2350	1.0263 1.1265 530658	2.3755 2.3760	1.583 1.587
360 Large Bore IO-240 IOF-240	654793 ^{3, 4} Superseded 646320 642268	646116 Superseded 626119	654487 Nut 655959 Bolt	6.3730 6.3770	1.0620 1.0630	1.000 1.0005 538584	2.0615 2.0620	1.2215 1.2255
360 Small Bore GO-300	654794 ^{3, 4} Superseded 646321 626128	646116 Superseded 626119	654487 Nut 655959 Bolt	6.3730 6.3770	1.0620 1.0630	1.000 1.0005 538584	2.0615 2.0620	1.3015 1.3055
O-200 O-300 C-90 C-145	654795 ^{3, 4} Superseded 646322 530184 ⁶ 5561 ⁶	646116 Superseded 626119 530186 ⁶	654487 Nut 655959 Bolt	6.3730 6.3770	1.0620 1.0630	0.9230 -0.9235 530192	2.0615 2.0620	1.3015 1.3055
IO / TSIO-520 Large Bore TSIO-520-BE	655911 ³ Superseded 655005 ⁴ 646476 646475	646126 Superseded 632041	654490 Nut 655958 Bolt	6.6230 6.6270	1.2340 1.2350	1.1267 1.1269 530658	2.3755 2.3760	1.461 1.465



Non-Overhaul Repair and Replacement

Table 10-38. Connecting Rod Specifications

Engine Model	Connecting Rod Part Number	Forging Part Number	Nut P/N ^{1, 2} Bolt P/N	Connecting Rod Bores Centerline Distance "A"	Piston Pin Bore I.D. (No Bushing) "B"	Piston Pin Bushing I.D. Bushing P/N "C"	Crankpin Bore I.D. "D"	Connecting Rod End Width "E"
L/TSIO-520-AE	655910 ³ Superseded	646126 Superseded	654490 Nut	6.6230	1.2340	1.1267	2.3755	1.521
	655000 ⁴ 646480 643166	632041	655958 Bolt	6.6270	1.2350	1.1269 530658	2.3760	1.525
TSIO-520-CE IO-550 TSIO-550 TSIOL-550	655911 ³ Superseded	646126 Superseded	654490 Nut	6.6230	1.2340	1.1267	2.3755	1.461
	655001 646482	632041	655928 Bolt	6.6270	1.2350	1.1269 530658	2.3760	1.465
IO-550-B29, B33, B37, C25, C30 TSIO-520-UB17	655911 ^{3 7} Superseded	646126 Superseded	654490 Nut	6.6230	1.2340	1.1267	2.3755	1.461
	655001 654440	632041	655928 Bolt	6.6270	1.2350	1.1269 530658	2.3760	1.465
GTSIO-520	655910 ³ Superseded	646126 Superseded	654490 Nut	6.6230	1.2340	1.1267	2.3755	1.521
	655004	632041	655958 Bolt	6.6270	1.2350	1.1269 530658	2.3760	1.525

1. The most current part number connecting rod nuts and bolts must not be used on or with superseded part number nuts and bolts
2. See Appendix B for Nut and Bolt torque specifications
3. Connecting Rod Assembly must use corresponding Bolt and Nut specified in column 4 of table.
4. Current part number (serviceable) connecting rods must use the most current part number connecting rod new nuts and bolts. The most current connecting rod new nut and bolt part numbers can be used with old (serviceable) connecting rods of the same style. (Hex head rod bolts must replace hex head rod bolts, contour head rod bolts must replace contour head rod bolts.)
5. Part No. A36121 connecting rod assemblies utilizing Part No. 632041 forging must be serviced according to table.
Part No. A36121 connecting rod assemblies utilizing the Part No. 40742 forging must be serviced with Part No. 35972 connecting rod bolt, Part No. 24804 nut and Part No. MS24665-132 cotter pin; torque to the value specified in Appendix B.
6. Part No. A36121 connecting rod (identified by forging number 530186), A35159 (Identified by forging number 5561) and A35160 (Also identified by forging number 5561) must be serviced with Part No. 530213 bolt, Part No. 24804 or Part No. 626140 nut and Part No. 639292 cotter pin, torqued to value specified in Appendix B.
7. Used in Balanced Set Part No. 655913



10-9.4.2. Connecting Rod Piston Pin Bushing Replacement

Replace all connecting rod piston pin bushings at overhaul.

Equipment Required

- Arbor press
- Borroughs Part No. 8098, Connecting Rod Bushing Removal/Installation Set, or equivalent
- Borroughs Part No. 8111A, Connecting Rod Boring and Alignment Fixture, or equivalent
- High speed borer of the correct size
- Borroughs Part No. 8042C Adapter Kit, or equivalent (E-Series, 470, 520 engines) or Part No. 8072C (240, 300, 360 engines), or equivalent
- Vertical mill, or equivalent, capable of maintaining 1750 RPM.
- Federal Dimension D-2500 or D-4000 Air Plug Gauge with a 1.1268 setting ring and 1.1268 air plug, or equivalent)
- Profilometer

WARNING

Use only the special tools listed. Removing and installing connecting rod bushings with makeshift tools can damage the connecting rods.

Verify the piston pin bushing being installed is the correct part number for the application. Use a Connecting Rod Bushing Removal/Installation Set (Borroughs Part No. 8098 or equivalent) and an arbor press to install the piston pin bushing as follows:

1. Press out the old piston pin bushing using the Connecting Rod Bushing Removal/Installation Set and an arbor press. Verify the connecting rod bore is smooth.
2. Verify the new bushing part number. Dip the new piston pin bushing in clean 50 weight aviation engine oil before placing it in position. The bushing may be chilled to aid installation.
3. Visually inspect the piston pin bushing bore to determine acceptability of parts. No nicks or gouges are permissible on the bore after the bushing is removed. Discard the connecting rod if nicks/gouges are found.
4. Position the connecting rod over the pilot so the mate marks and piston pin bore chamfer are facing up.
5. Place the piston pin bushing on the pilot so that the bushing split is located $45^\circ \pm 5^\circ$ from the center line of the connecting rod, facing the crankpin end. Refer to the Connecting Rod dimensions in Figure 10-42 and Table 10-38.
6. Position the ram onto the pilot.
7. Using the arbor press, carefully press the new piston pin bushing flush with the piston pin bore.



Non-Overhaul Repair and Replacement

8. Bore the new piston pin bushing to the diameter specified in Figure 10-42 and Table 10-38 according to the “Connecting Rod Piston Pin Bushing Boring” in Section 10-9.4.3.
9. Visually inspect the connecting rod for nicks or damage that may have occurred during bushing installation. Scrap connecting rods exhibiting these conditions.
10. Verify the piston pin bushing split line meets Figure 10-42 specifications.
11. Because of the close tolerances required, inspect the new piston pin bushing; note the bushing bore inner diameter must meet Table 10-38 specifications:
 - a. Use a Federal Dimension Air Gauge (with the appropriate setting ring and air plug) to verify that the piston pin bushing is within the connecting rod minimum and maximum limits specified in Table 10-38.
 - b. Check the piston pin bushing surface finish with a profilometer. The surface finish must not exceed 16 Ra.
 - c. Check the connecting rod bushing for alignment and twist after bushing installation using the Connecting Rod Boring and Alignment Fixture (Borroughs Part No. 8111A or equivalent). To check the connecting rod twist, insert the push-to-fit arbors into the pin and crank end of the rod.
 - d. Place the connecting rod crank pin end onto the V-blocks.
 - e. Place the pin end arbor on the two machined parallel steel blocks spaced equal distance from the center line of the rod, but not less than 6 inches apart.
 - f. Use a flat feeler gauge to detect clearance between the machined steel blocks and the pin end arbor. Refer to the connecting rod dimensions in Table 10-38 for specified limits.
 - g. To check the connecting rod alignment, rotate the pin end of the connecting rod to a vertical position and with the arbor resting against a positive stop.

NOTE: The piston pin bushing must be bored to the proper inside diameter according to the “Connecting Rod Piston Pin Bushing Boring” instructions in Section 10-9.4.3.

- h. Using a dial indicator mounted on a vertical stand resting on the surface plate, measure the vertical distance of the pin end arbor from the surface plate at points of equal distance from the centerline of the connecting rod. Compare the connecting rod measurements to the connecting rod dimensions in Table 10-38. Connecting rods exceeding Table 10-38 limits must have the piston pin bushing replaced and reamed or the connecting rod must be scrapped.



10-9.4.3. Connecting Rod Piston Pin Bushing Boring

Equipment Required

- Borroughs Part No. 8111A, Connecting Rod Boring and Alignment Fixture, or equivalent
- Adapter Kit
- Vertical mill, or equivalent, capable of maintaining 1750 RPM
- Boring tool of the correct sizes

1. Place the connecting rod on the base plate and secure with retainers provided.
2. Select the correct adapter kit and boring tool for the connecting rod.
3. Using a vertical mill, or equivalent, bore the connecting rod bushing to size. Maintain 1750 RPM during the boring process.



10-10. Crankshaft Nose Oil Seal Replacement

Replace the crankshaft nose oil seal if it is damaged or if the following conditions exist:

- Ram air is entering the engine interior
- Oil leaks from the nose seal or nose seal retainers

10-10.1. Solid Nose Oil Seal Removal

NOTE: Instructions in this section apply only to stretch over type oil seals.

WARNING

Turn the Ignition Switch OFF and disconnect engine electrical power before commencing maintenance or inspections. Confirm continuity between the magneto capacitor and aircraft ground to prevent accidental engine start during maintenance. Do not stand or place equipment within the arc of the propeller.

1. Turn the Ignition Switch OFF and disconnect engine electrical power.
2. Disconnect all spark plug leads.
3. Set the brakes and block the aircraft wheels.
4. Ensure that aircraft tie-downs are installed and the cabin door latch is open.
5. Remove the propeller according to the propeller and aircraft manufacturer's instructions.

CAUTION: Do not scratch, mar, or damage the crankshaft or crankcase while removing the crankshaft nose oil seal.

6. Remove the screws and the retainer plates (Figure 10-43) from the crankcase.

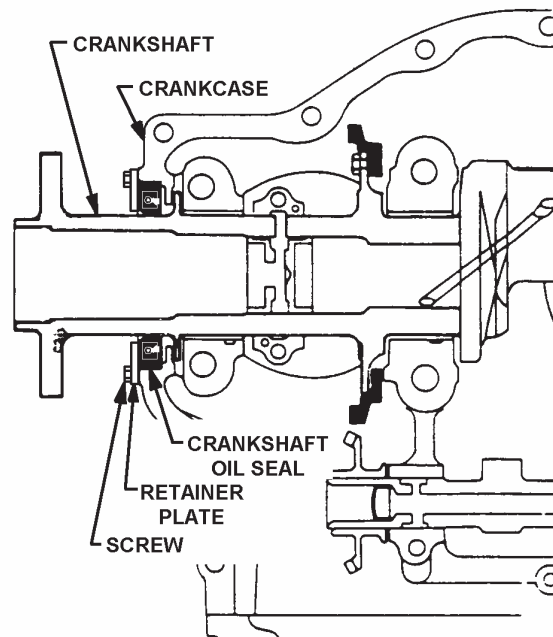

Figure 10-43. Retainer Plate and Screws on Front of Crankcase



7. Remove the crankshaft nose oil seal, reinforcing ring (if used), and spring as shown in Figure 10-44). Gentle force may be required to remove the nose oil seal parts from the counterbore.
8. Inspect the propeller mounting flange carefully to insure that no nicks, burrs or sharp edges are present which could damage the oil seal surface during installation.
9. Clean surfaces thoroughly making certain that no foreign material remains on the shaft or in the seal counterbore. Wash oil seal counterbore area with acetone. To remove the Gasket Maker residue out of the counterbore recess using a chlorinated solvent such as Loctite Chisel[®] or methylene chloride followed by a naptha solvent such as Loctite ODC-Free Cleaner and Degreaser. Remove all residue and debris from the bore.

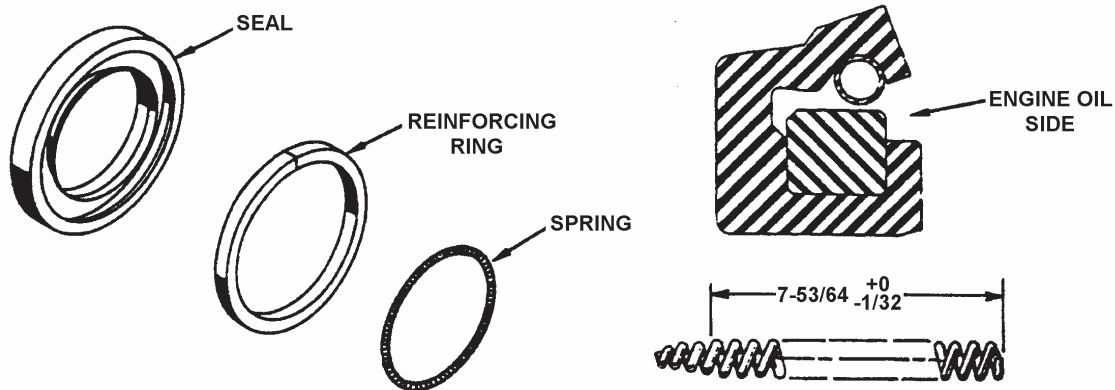

Figure 10-44. Crankshaft Nose Oil Seal Parts

10. Prepare the exposed portion of the crankshaft according to the instructions in Section 10-9.3.

10-10.2. Solid Nose Oil Seal Installation

WARNING

Turn the Ignition Switch OFF and disconnect engine electrical power before commencing maintenance or inspections. Confirm continuity between the magneto capacitor and aircraft ground to prevent accidental engine start during maintenance. Do not stand or place equipment within the arc of the propeller.

1. Prepare the exposed portion of the crankshaft with a fresh helix pattern according to instructions in Section 10-9.3.
2. Remove the spring and reinforcing ring from the crankshaft nose oil seal.
3. Unhook the spring ends using an unwinding motion.
4. Verify the seal spring length is 7.80" to 7.83" as illustrated in Figure 10-44. If the spring length is not within this tolerance, replace it.
5. Place the spring around the crankshaft in the helix area.



Non-Overhaul Repair and Replacement

6. Turn the spring ends in an unwinding direction and allow one end to wind into the other end.
7. Apply Shell Alvania No. 2 Grease to the lip of the new seal and the propeller flange.
8. Squeeze the seal until it is egg shaped and install it on the crankshaft, groove side in, starting from the bottom of the propeller flange using the Crankshaft Oil Seal Installer Tool (Chapter 3, Kent-Moore Part No. 5209).
9. After the oil seal is installed on the crankshaft, wipe the grease from the oil seal and crankshaft. Verify the outer diameter of the oil seal is clean and dry.
10. Press the reinforcing ring into the oil seal recess in both directions from the split. Ensure the reinforcing ring is in the deepest part of the recess all the way around.
11. Install the spring in the oil seal cavity.
12. Spray a thin film of Part No. 653692 Primer on the oil seal counterbore and allow it to dry for 1 to 2 minutes.
13. Apply a translucent coat of Gasket Maker (Part No. 646942) to the oil seal counterbore. Refer to Gasket Maker application instructions in Appendix C.
14. Apply Gasket Sealant (Part No. 654663) to the outside diameter of the oil seal.
15. Using thumb pressure, work the seal into the crankcase counterbore.
16. After the seal is in place, wipe any remaining sealant from the seal and crankshaft.
17. Spray the exposed portion of the lightly scratched crisscross area with aluminum paint and allow it to dry.
- 18. Apply Part No. 653693, General Purpose Primer, to the crankcase oil seal retainer screw holes.
- 19. Apply Part No. 646941, High Strength Adhesive Sealant, to the oil seal retainer screws.
20. Install the crankshaft nose oil seal retainer plates and secure them with the nose oil seal retainer screws. Torque the screws to Appendix B specifications.
21. Inspect the propeller according to the propeller manufacturer's and aircraft manufacturer's instructions.
22. Install the propeller, if serviceable, according to the propeller manufacturer's and aircraft manufacturer's instructions.
23. Perform a normal "Engine Start" (Section 7-3.2) and "Ground Run-up" (Section 7-3.3). Run the engine for a minimum of five minutes to reach normal operating temperatures. Shut down the engine according to the "Engine Shutdown" (Section 7-3.4) instructions and inspect the Crankcase Nose Oil Seal area for leaks.



10-10.3. Split Nose Oil Seal Removal

Follow same procedures listed for stretch type oil seals except it is not necessary to remove the propeller. With the propeller installed, any removal of plating or blending of the 1” area referred to in Section 10-10.1 will have to be accomplished manually without engine rotation.

NOTE: On left hand rotating engines (LTSIO360) the helix must be applied in the opposite direction as shown in Figure 10-41. Stroke the strip of emery cloth outward toward the flange in the direction of rotation (CW toward you using maximum hand pressure.).

10-10.4. Split Type Nose Oil Seal Installation

1. Prepare the exposed portion of the crankshaft with a fresh helix pattern according to the instructions in Section 10-9.3.
2. Use appropriate split type nose oil seal depending on engine model (refer to illustrated parts catalog).
3. Remove the spring (Figure 10-45) from the new crankshaft nose oil seal assembly and unhook the spring ends.
4. Verify the seal spring length is 7.53” to 7.59” as illustrated in Figure 10-45. If the spring length is not within this tolerance, replace it.
5. Place the spring around the crankshaft in the helix area and connect the ends of the spring.
6. Apply Part No. 654561, Shell Alvania No. 2 Grease to the lip of the new oil seal and the crankshaft propeller flange.
7. Install a new oil seal on the crankshaft outboard of the spring with the opening facing the crankcase.

CAUTION: The nose oil seal split line must not align with the crankcase mating flanges.

8. Position the split line of the crankshaft nose oil seal at the 2:00 or 4:00 o'clock position of the crankcase.
9. Position the spring hooks 180° away from the split line of the nose oil seal and install the spring in the oil seal cavity.
10. After the seal is positioned on the crankshaft, wipe the grease from the oil seal and crankshaft. Verify the outer diameter of the oil seal is clean and dry.
11. Mask the crankshaft where it exits the crankcase. Spray a thin film of Part No. 653692, Primer, on the oil seal counterbore and allow it to dry for one to two minutes.
12. Apply Part No. 646942, Gasket Maker to the crankcase oil seal counterbore. Remove the masking tape from the crankshaft.
13. Apply a translucent coat of Part No. 654663 Gasket Sealant on the outer diameter of the oil seal.



Non-Overhaul Repair and Replacement

- Using thumb pressure, work the seal and spring into the crankcase counterbore. Ensure the seal is in the deepest part of the recess all the way around.

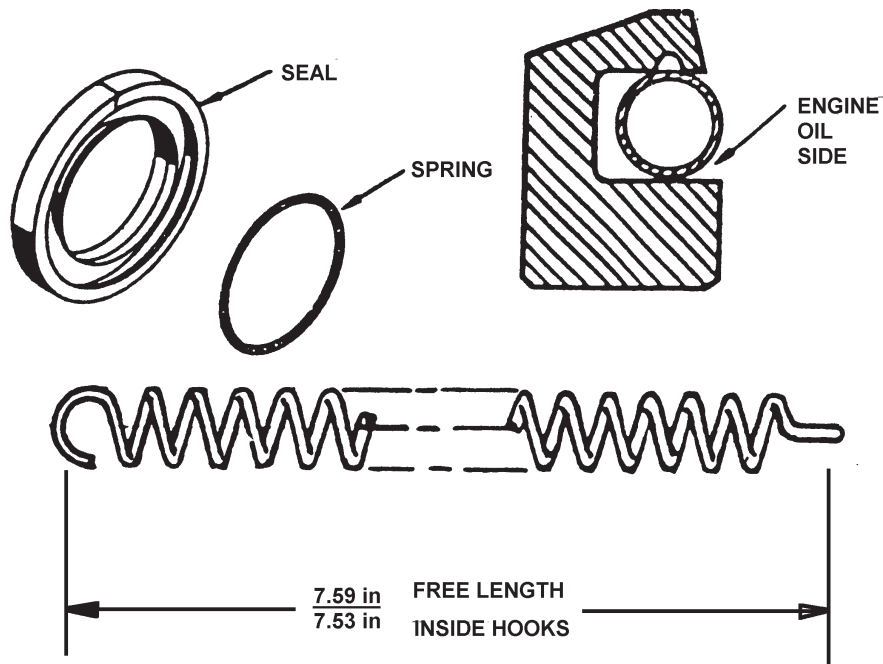

Figure 10-45. Split Nose Oil Seal Parts

- After the seal is in place, wipe any remaining sealant from the seal and crankshaft.
- Spray the exposed portion of the lightly scratched crisscross area with aluminum paint and allow it to dry.

NOTE: The following steps apply only to engines utilizing oil seal retainer plates.

- Apply Part No. 653693, General Purpose Primer, to the crankcase oil seal retainer screw holes.
- Apply Part No. 646941, High Strength Adhesive Sealant, to the oil seal retainer screws.
- Install the crankshaft nose oil seal retainer plates and secure them with screws. Torque the screws to the value specified in the applicable Maintenance and Overhaul Manual (Section 1-1.1).
- Perform a normal “Engine Start” (Section 7-3.2) and “Ground Run-up” (Section 7-3.3). Run the engine for a minimum of five minutes to reach normal operating temperatures. Shut down the engine according to the “Engine Shutdown” (Section 7-3.4) instructions and inspect the Crankcase Nose Oil Seal area for leaks.



10-11. Exhaust Flange to Cylinder Installation

Exhaust systems on most turbocharged engines are supplied with the engine. Exhaust systems on naturally aspirated engines are supplied by the aircraft manufacturer. Continental Motors recommends the following information for connecting the exhaust flange to the cylinder, regardless of the source of the exhaust system.

1. Before connecting the exhaust system to the cylinder(s), inspect the cylinders, exhaust flanges, and exhaust studs for serviceability and security (see Section 6-4.21 and the primary ICA).
2. Install gaskets and properly position the exhaust system on the cylinders. Ensure the exhaust flanges mate properly to the cylinder.
3. Lubricate the exhaust studs with clean 50 weight aviation engine oil.
4. Evenly torque exhaust nuts to the specified torque value in Table 10-39 and Appendix B.
5. Perform ground run-up to normal operating temperature according to the Airplane Flight Manual/ Pilot's Operating Handbook (AFM/POH) published by the aircraft manufacturer.
6. Inspect exhaust system for leaks and security prior to return to service (Section 6-4.21).
7. After completing ground run-up, re-torque exhaust nuts to final torque value.



Non-Overhaul Repair and Replacement

Table 10-39. Exhaust Gaskets, Nuts, and Nut Torque Values

ENGINE	MODELS	GASKET	NUT	TORQUE VALUE		NOTES
				IN. LBS.	FT. LBS.	
A65	All Models	632837 or 652459	22022	200-210	16.7-17.5	
C75						
C85						
C90						
O200	A, B, C, D & X		MS20500-524	100-110	8.3-9.2	
C125	All Models		22022	200-210	16.7-17.5	
C145						
O300			MS20500-524	100-110	8.3-9.2	
GO300						
E165						
E185		MS20500-428				
E225						
IO240	All Models	630365	22022	200-210	16.7-17.5	Use two each gaskets per exhaust port, concave sides together.
IOF240						
IO360						
LTSIO360						
TSIO360						
O470	All Models (except J)	631544 or 652458	MS20500-428	100-110	8.3-9.2	4-Hole Gasket
	J Model Only	632837 or 652459				2-Hole Gasket
IO470	All Models (except J & K)	631544 or 652458				200-210
	J & K Models Only	632837 or 652459				
TSIO470	All Models	631544 or 652458	MS20500-428	100-110	8.3-9.2	4-Hole Gasket
IO520						
GTSIO520						
LTSIO520	AE Model Only	652459	MS20500-428	100-110	8.3-9.2	2-Hole Gasket
TSIO520	All Models except AE	631544 or 652458				4-Hole Gasket
	AE Model Only	652459				2-Hole Gasket
IO550	All Models	631544 or 652458	MS20500-428	100-110	8.3-9.2	4-Hole Gasket
IOF5550						
TSIO550						
TSIOF550						
TSIOL550						



Chapter 11. Non-Destructive Inspection

11-1. Visual Inspection

Perform a visual inspection on all parts not specified as 100% replacement (Appendix C-2.3 or C-2.4) at overhaul. Examine parts prior to being cleaned for obvious evidence of wear or leakage. Reject obviously damaged parts during the preliminary visual inspection, there is no need to clean and perform non-destructive inspection on parts which cannot be used. If condition is uncertain, clean with remaining parts after the preliminary exam, according to the “Engine Cleaning” instructions in the Chapter 12. Verify the parts are clean and free of all carbon, dirt, grease, oil, soot, varnish, gum, and paint.

1. Visually inspect the parts using at least a 10X (power) magnifying glass under good lighting. Look for the following unacceptable conditions:
 - Nicks
 - Dents
 - Gouges
 - Cracks
 - Distortion
 - Burned areas
 - Pitting
 - Metal transfer
 - Corrosion
 - Erosion
 - Enamel coating wear
2. Inspect all studs for bending, looseness or partial removal.
3. Inspect all threaded parts for nicks, damaged or deformed threads, faces, or heads.
4. Identify areas that warrant further cleaning.
5. Label parts which fail inspection; indicating reason for failure and if repair is possible or if replacement is required.

11-1.1. Gear Tooth Inspection

Inspect the gear teeth for signs of overheating and wear. Normal wear produces a fine polish on the tooth thrust faces. Gears with uneven teeth profiles, score marks, burning, or pitting are unacceptable. Refer to Figure 11-1 for sample illustrated comparisons of acceptable and unacceptable gear wear.

Discard and replace unacceptable gears.

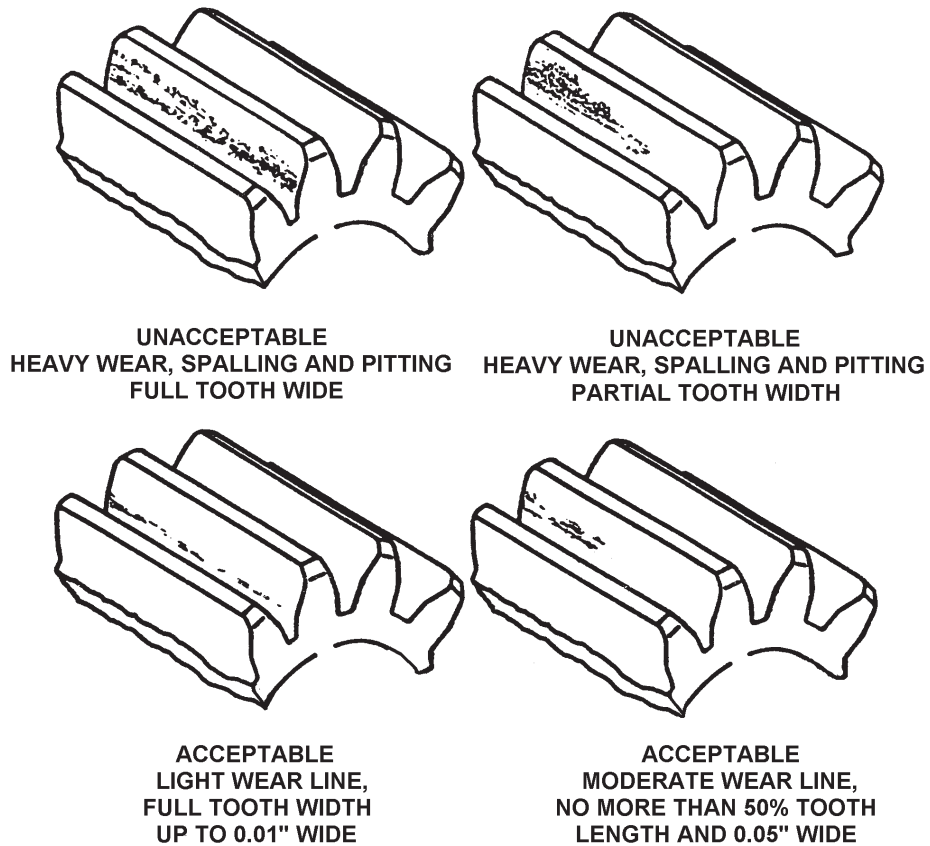

Figure 11-1. Gear Inspection Criteria



11-2. Fluorescent Penetrant Inspection

Perform this inspection on all cleaned, aluminum or non-ferrous metal parts, including the parts listed below in accordance with ASTM E1417, E1208, E1209, E1219, and Type 1 Fluorescent Penetrant Method A, B, C, or D. For accurate results, parts should be free of paint and all foreign substances, such as carbon, dirt, grease, oil, soot, varnish, gum, and paint. Inspection shall be performed by personnel certified to Level II using methods approved by a Level III certified inspector.

Table 11-1. Parts Requiring Fluorescent Penetrant Inspection

Inspect:	Pay particular attention to:
<ul style="list-style-type: none"> • Accessory case, including oil pump cavity • Accessory drive housing • Brackets (non-ferrous) • Crankcase halves • Cylinder heads • Engine mounts • Induction manifolds • Induction risers • Induction tubes • Intake/exhaust valves • Oil cooler mount • Oil filter adapter • Oil sumps (non-ferrous) • Starter adapter housings 	<ul style="list-style-type: none"> • Areas where oil seals or bushings are pressed in or seated • Bearing bosses • Area between cylinder head cooling fins • Areas surrounding through-bolt holes • Crankcase/crankshaft exit area • Cylinder-to-barrel mating area • Intake and exhaust flanges • Intake and exhaust ports • Oil pump cavity area mounting flanges • Mounting and attaching areas where hardware has been previously torqued • Rocker boss areas • Shaft bores • Valve seat insert areas • Valve guide areas

1. Inspect non-ferrous parts for the following conditions:
 - a. Cracks, or indications of the start of cracks
 - b. Unauthorized grinding encountered after the manufacturing process.
 - c. Unauthorized welding

Unless the overhaul repair instructions in the Maintenance and Overhaul (or Overhaul) Manual contains specific instructions to remedy unsatisfactory conditions discovered during the inspection, discard parts which exhibit any of the conditions described in steps 1a through 1c.

2. Look for indications which break into corners, edges, holes, or fillets on parts. Identify parts that contain linear indications; repair is authorized by licensed repair station only.
3. Follow the fluorescent penetrant manufacturer's instructions for the equipment and materials used to perform the inspection regarding use, safety data, and disposal.
4. Label each part's inspection status and required action.
5. Follow the fluorescent penetrant manufacturer's instructions to remove penetrant residue from the inspected, serviceable parts.



11-3. Magnetic Particle Inspection

Prior to performing a Magnetic Particle Inspection, verify the parts are clean and free of carbon, dirt, grease, oil, soot, varnish, gum, and paint. Plating shall not be intentionally removed.

CAUTION: Prior to Magnetic Particle Inspection, ensure that the parts have been thoroughly cleaned and dried according to the instructions in of the Maintenance and Overhaul (or Overhaul) Manual.

The Magnetic Particle Inspection must be performed by a certified technician on cleaned, ferrous parts according to ASTM E1444 using the wet continuous method and full wave rectified alternating current and fluorescent particles. Follow the particular magnetic particle media manufacturer's instructions regarding use, safety data, and disposal. Inspection shall be performed by personnel certified to Level II using methods approved by a Level III certified inspector.

1. Follow the equipment and materials manufacturer's instructions to perform the inspection regarding use, safety data, and disposal. Use the corresponding method of magnetization and amperage listed in Table 11-2. Perform circular, followed by longitudinal inspection.
2. Inspect parts for the following conditions:
 - a. Cracks or indications of the start of cracks
 - b. Unauthorized grinding encountered after the manufacturing process
 - c. Pits

Unless the Maintenance and Overhaul (or Overhaul) Manual contains specific instructions to remedy unsatisfactory conditions discovered during the inspection, discard parts which exhibit any of the conditions described in steps 2a through 2c.

3. Record repair or replacement requirements.
4. Look for linear indications which may break into corners, edges, holes, thread roots, fillets, gear tooth roots or keyways on parts. Identify parts which contain relevant linear indications which cannot be reworked.
5. Label parts which fail inspection as such; indicate reason for failure and if repair or replacement action is required. Repair is authorized by licensed repair station only.
6. Demagnetize the parts to less than 3 gauss.
7. Clean the inspected parts thoroughly according to the "Engine Cleaning" instructions in Chapter 12.

CAUTION: When utilizing compressed air, wear OSHA approved protective eye wear. Never exceed 30 psi when using compressed gases for cleaning purposes (OSHA 1910.242(b)). Dry the parts with compressed air.

8. Dry the parts with compressed air.



Table 11-2. Magnetic Particle Inspection Reference

Part	Method of Magnetization	Amperes	Focus	Inspect for
Camshaft	Circular and Longitudinal	1500	<ul style="list-style-type: none"> • Lobes • Journals • Drilled hole edges 	<ul style="list-style-type: none"> • Heat stress cracks • Cracks
Connecting rod ¹	Circular and Longitudinal	1500	All areas	Cracks
Crankshaft	Circular	2000	<ul style="list-style-type: none"> • Journals • Fillets • Oil holes 	<ul style="list-style-type: none"> • Cracks • Heat cracks
	Longitudinal		<ul style="list-style-type: none"> • Thrust flanges • Prop flange 	<ul style="list-style-type: none"> • Flange cracks from prop strike
Cylinder barrels	Circular and Longitudinal	1500	<ul style="list-style-type: none"> • Fin tips • Fin roots • Flange • Flange bolt holes 	<ul style="list-style-type: none"> • Cracks • Heat stress cracks
Gears	Circular and Longitudinal	1000 to 1500	<ul style="list-style-type: none"> • Teeth • Splines • Keyways 	Cracks
Piston Pin ²	Circular and Longitudinal	1000	<ul style="list-style-type: none"> • Shear planes • Ends • Center 	Cracks
Rocker arms	Circular 12 parts on central conductor	1000	<ul style="list-style-type: none"> • Pad • Socket under side arms and boss 	Cracks
	Longitudinal 12 parts on central conductor	1200		
Shafts	Circular and Longitudinal	1000 to 1500	<ul style="list-style-type: none"> • Splines • Keyways • Section transitions 	<ul style="list-style-type: none"> • Cracks • Heat stress cracks
Through-bolts and connecting rod bolts ²	Circular and Longitudinal	500	Threads	Cracks

1. Inspect connecting rod and cap according to the "Connecting Rod Magnetic Particle Inspection" in Section 11-3.1.
2. Perform only on in service parts; replace 100% at overhaul



11-3.1. Connecting Rod Magnetic Particle Inspection

Before performing the Connecting Rod Magnetic Particle Inspection, the connecting rod and cap must be clean and free of rust, scale, oil, or other residue that may affect the reliability of the Magnetic Particle Inspection. Inspect the connecting rods using both the circular and longitudinal method of magnetization. Use the fluorescent method, wet continuous procedure, reference ASTM standards for non-destructive testing.

Refer to the Table 11-3 for inspection pass/fail criteria. Record inspection findings on a checklist.

NOTE: Reject connecting rod or caps exhibiting the unacceptable indications listed in the **Fail** column of Table 11-3.

Table 11-3. Connecting Rod Magnetic Particle Inspection Criteria

Pass	Fail
Steel inclusions or shallow imperfections on the forging surface - light indications running parallel to the rod axis or around the pin boss and cap ends less than ½-inch in length	Indications associated with cracks
Blend area between the piston pin boss extending 1-inch into connecting rod I beam, the bolt spot face areas and the channel rail edges are free of any indications of cracks/wear	Area of blend between the piston pin boss extending 1-inch into connecting rod I beam, the bolt spot face areas and the channel rail edges shows indications of cracks/wear
	Any indication transverse to the rod axis.



11-4. Ultrasonic Inspection

Reference: **MSB96-10**

The inspections must be performed on all six cylinder, spark ignited, aviation gasoline (AvGas) engine crankshafts by technicians possessing inspection certification credentials according to Section 11-4.1, "Ultrasonic Inspection Certification."

The item to be inspected must have sufficient mass to perform the Ultrasonic Inspection. Ultrasonic Inspection is not possible on four cylinder engine model crankshafts.

11-4.1. Ultrasonic Inspection Certification

Cylinder and crankshaft nondestructive testing (NDT) inspectors must possess a current certification to perform the inspection according to Continental Motors specifications. Training is available from Plumstead Quality and Training Services (PQT) Company. PQT offers training at various locations in the United States of America.

Courses available:

Continental Motors Ultrasonic Testing Level I, or

If previously certified as NDT Level II Inspector (IAW NAS 410):

Crankshaft Ultrasonic Testing Refresher

Consult the PQT web site for additional information:

Plumstead Quality and Training Services Company (PQT)

Phone: (904) 425-1381

www.PQT.net



11-4.2. Crankshaft Ultrasonic Inspection

Reference: **MSB96-10**

Perform an Ultrasonic Inspection on each crankshaft removed from the engine at the next and each subsequent removal from the engine according to the latest version of Continental Motors Material Handling Specification (MHS) 200.

NOTE: The ultrasonic inspection requirements set forth in the latest revision of **MSB96-10** instructions must be performed on crankshafts prior to installation. Ultrasonic inspection is performed on CM Factory new crankshafts prior to shipment to the customer and need not be repeated prior to initial installation.

NOTE: Any crankshaft listed in the latest revision of CM Service Bulletin CSB96-8 that is NOT verified as being a vacuum arc remelted (VAR) forging, must be replaced upon discovery.

WARNING

Do not steel stamp the inspection result on the crankshaft, it will damage the nitride finish. Genuine Continental Motors Crankshafts are stamped prior to nitride treatment.

Table 11-4. Crankshaft Ultrasonic Inspection Pass/Fail Action

Crankshaft Meets Inspection Criteria		Crankshaft Fails Inspection Criteria
Vibro-etch the crankshaft flange as illustrated in Figure 11-2 with both a "V" (vacuum arc remelted (VAR) verified) and a "U" (ultrasonic inspection) to identify the inspection method:		<ul style="list-style-type: none"> - Remove the crankshaft from service. - Destroy the crankshaft to so that it is no longer "serviceable or airworthy." - Replace the crankshaft with a new or serviceable VAR crankshaft. - Record inspection results
V/U	VAR Steel/Ultrasonic Inspected (Figure 11-2)	

NOTE: In some instances, the VAR identification may have been ground off in the balancing process and cannot be verified. If the VAR indication cannot be verified, replace with a new or serviceable VAR crankshaft.

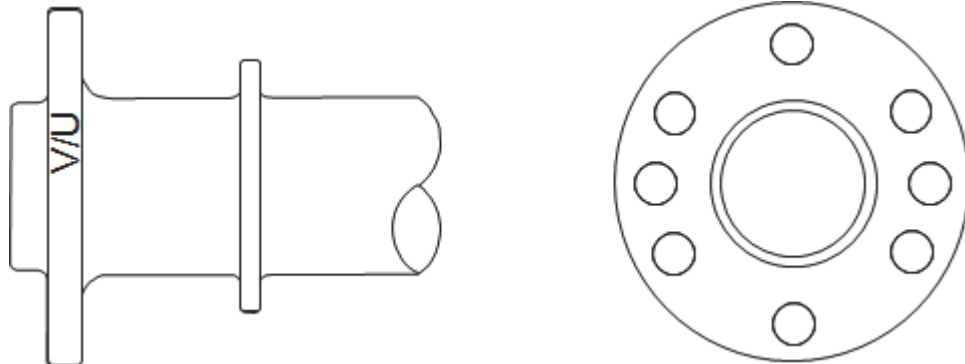

Figure 11-2. Crankshaft Ultrasonic Inspection Method Location



Chapter 12. Engine Cleaning

12-1. Engine and Component Cleaning

The goal of cleaning engine components is to remove dirt and contamination. A “cleaned” part is free of dirt, carbon, varnish, and gum substances. The “Aircraft Engine Parts Cleaning Guidelines” (Table 12-1) offer instructions for specific engine parts during overhaul or maintenance. Refer to the “Cleaning Tips” in Table 12-2 for additional guidelines.

WARNING

Consult the manufacturer’s Safety Data Sheet (SDS), formerly Material Safety Data Sheet (MSDS), for specific handling, storage and disposal instructions, including personal protective equipment requirements.

To prevent death or injury, do not smoke or introduce sources of ignition or flame to the work area when using flammable cleaning fluids such as mineral spirits.

Do not use gasoline, kerosene, abrasive cleaning paste, or cleansing powder to clean the engine or engine parts.

Do not pressure blast gears with abrasive media. Blasting will remove surface hardening.

When cleaning with alkaline solutions, remove all traces of alkaline residue to prevent corrosion. Alkaline cleaning solutions induce corrosion if not completely removed.

NOTE: Prior to cleaning engine parts, visually inspect for leakage and metal shavings, rust or other obvious signs of wear.



Table 12-1. Aircraft Engine Parts Cleaning Guidelines

Item to Clean	Instructions/References/Tips
Aluminum Parts, including: <ul style="list-style-type: none"> • Accessory case • Oil sump • Oil pump housing • Oil filter adapter • Tach drive adapter • Starter adapter housing, cover and oil passages 	Flush with mineral spirits (preferred cleansing agent). Alkaline stripping bath followed by steam rinse to remove all alkaline traces (to prevent corrosion); Dry with compressed air and inspect for traces of alkaline residue. Re-spray with steam if alkaline residue found; flush thoroughly with mineral spirits.
Aluminum alloy parts soiled or stained with carbon or gum deposits	Refer to "Cleaning Aluminum Alloy Parts" in Section 12-1.4.
Crankcase casting	Flush with mineral spirits (preferred cleansing agent). Alkaline stripping bath followed by steam rinse to remove all alkaline traces (to prevent corrosion); Dry with compressed air and inspect for traces of alkaline residue. Re-spray with steam if alkaline residue found; flush thoroughly with mineral spirits.
Crankcase oil passages Oil squirt nozzles	Pressure flush with mineral spirits to remove clogs or free obstructed passages. (Use caution flushing the oil squirt nozzles, they are not field replaceable)
<i>CAUTION: When utilizing compressed air, wear OSHA approved protective eye wear. Never exceed 30 psi when using compressed gases for cleaning purposes. (OSHA 1910.242(b))</i>	
Connecting rods, caps, bolts, and nuts	Thoroughly clean connecting rods using mineral spirits. Ensure that all surfaces are free of varnish, oil and residue. Place a sheet of crocus cloth on a flat surface plate and dampen with mineral spirits. Lightly rub the parting surface of the rod, cap and rod across crocus cloth to remove burrs or nicks. Clean the connecting rods, caps, bolts and nuts thoroughly. Dry the cleaned part with compressed air and place on a clean cloth.
Connecting rod bearing inserts	Clean the new bearing inserts in mineral spirits and dry with compressed air.
Crankshaft or camshaft	Degrease with mineral spirits (brushing or spraying). Remove all varnish or gummy deposits. Place the crankshaft or camshaft in a machinist's lathe and rotate at approximately 100 RPM, smooth the following with crocus cloth moistened in mineral spirits: <ul style="list-style-type: none"> • Crankshaft crank pins • Main journals • Oil seal race • Camshaft journals • Gear mount flange Clean all debris from bolt holes, threads, oil passages, and recesses
Crankshaft and camshaft gears ¹ with bushings ²	Mineral spirits and a brass wire brush
Crankshaft and camshaft gears ¹ without bushings	Flush with mineral spirits (preferred cleansing agent). Alkaline stripping bath followed by steam rinse to remove all alkaline traces (to prevent corrosion); after drying, inspect for traces of alkaline residue and re-spray with steam. Flush alkaline residue with mineral spirits.



Table 12-1. Aircraft Engine Parts Cleaning Guidelines

Item to Clean	Instructions/References/Tips
Crankshaft counterweights ¹	Mineral spirits
Cylinders ³	Refer to "Cylinder Cleaning" instructions in Section 12-1.4.
Cylinder intake valves	<ul style="list-style-type: none"> • Degrease intake valves with mineral spirits. • Remove all carbon, varnish and gum either using a carbon solvent or by dry blasting according to instructions in Section 12-2, "Dry Blasting." If dry blasting is performed, clean the valve with mineral spirits and air dry.
Cylinder baffles and cylinder hardware	Mineral spirits
Electrical connectors	<ul style="list-style-type: none"> • Electrical contact cleaner CR4 • Do not use water-base or petroleum-base solvent to clean connectors • If a cleaning fluid is suspected to have entered a connector, blow the excess away from the connector and place the effected component(s) in a warm dry environment; i.e. 90°F (32°C), overnight or until thoroughly dry. • As applicable, replace the sealant strip in the connector if any damage to the seal is evident.
<p>WARNING</p> <p>Except when removing carbon deposits and gum (oil varnish), do not use alkaline (caustic) cleaning solutions for external engine cleaning. Alkaline solutions remove the alodine finish of aluminum parts.</p>	
Engine and component exterior surfaces	Spray or brush cleaning solvent (mild detergent or mineral spirits) on the engine or engine component exterior.
Engine mount brackets	Mineral spirits
Exhaust system multi-segment V-band clamps	Clean clamps using crocus cloth on the outer band of the clamp assembly. Use Stoddard solvent to clean the rest of the clamp
<p><i>CAUTION: Never insert any object (wire, pipe cleaner, brush, etc.) in the fuel injector nozzle. If stain or obstruction cannot be removed with solvent or air, replace the nozzle.</i></p>	
Fuel injectors FADEC engines only	Cannot be cleaned; remove and replace fuel injectors
Fuel injectors CMI Continuous Flow Fuel Injection only Fuel distribution block FADEC engines only	Immerse in an ultrasonic cleaner bath, adhere to the ultrasonic cleaner manufacturer's instructions. If ultrasonic cleaner is not available: <ul style="list-style-type: none"> • Acetone • MEK • Lacquer thinner Soak in solvent (acetone, lacquer thinner or MEK) to remove gum and fuel varnish stains and deposits. Use clean, oil free air to remove residue and dry the inside of nozzle.
Fuel filters/screens	Immerse in an ultrasonic cleaner bath, adhere to the ultrasonic cleaner manufacturer's instructions. If ultrasonic cleaner is not available, flush with clean Stoddard solvent into white filter paper until no particulate residue is evident on the filter paper.



Table 12-1. Aircraft Engine Parts Cleaning Guidelines

Item to Clean	Instructions/References/Tips
Fuel manifold valve	Mineral spirits
Gears without bushings ¹	Flush with mineral spirits (preferred cleansing agent). Alkaline stripping bath followed by steam rinse to remove all alkaline traces (to prevent corrosion); Dry with compressed air and inspect for traces of alkaline residue. Re-spray with steam if alkaline residue found; flush thoroughly with mineral spirits
Gears ¹ with bushings ²	Mineral spirits and a brass wire brush
Gasket surfaces on castings	Remove all old adhesive gasket material using the organic solvents listed below: <ul style="list-style-type: none"> • Acetone • Naptha • Methyl ethyl ketone (MEK) When removing the crankshaft nose oil seal, clean the Gasket Maker residue out of the counterbore recess using a chlorinated solvent Loctite Chisel [®] or methylene chloride followed by a naptha solvent such as Loctite ODC-Free cleaner and degreaser. Remove all debris to render the bore clean, without any trace debris.
NOTE: All oil passages must be clear	
Oil cooler/intercooler/aftercooler	Must be cleaned by an FAA-certified repair facility
Oil suction tube assembly Speed sensor (FADEC)	Mineral spirits
Overboost valve	Stoddard solvent and compressed air to remove deposits
Piston tops	To remove heavy carbon deposits on the piston tops, use vapor grit method - Refer to "Vapor Blasting" in Section 12-3.
Pushrods and rocker arms	Soak in mineral spirits. Ensure passages within the pushrod and rocker arm are open by flushing the passages with mineral spirits using a squirt bottle. Discard and replace any pushrod or rocker arm that has obstructed passages and cannot be cleared. Do NOT clean pushrods or rocker arms by dry blasting.
Small steel parts	Spray or brush on mineral spirits to degrease the part. Soak heavily soiled parts for 15 minutes in mineral spirits.
Starter/starter adapter gears ¹ with bushings ²	Mineral spirits and a brass wire brush
Starter adapter worm shaft	Mineral spirits
Spark plugs	Clean according to manufacturer's instructions.
Throttle control linkage pivot point areas	Stoddard solvent
Turbocharger wastegate actuator and butterfly valve	Stoddard solvent and compressed air to remove deposits. Apply Mouse Milk to the bearing surfaces, shafts and pivot points. Tap the butterfly shaft (only the shaft) with a rawhide mallet to free deposits.

1. Do not pressure blast gears or counterweights to clean them; blasting can remove the surface hardening
2. Do not use alkaline cleaning solutions
3. Do not use sand, glass shot, or metal grit to clean engine cylinders.



Table 12-2. Cleaning Tips

Dos	Don'ts
Use a cloth or compressed air to blow off the solvent.	Except when removing carbon deposits and gum (oil varnish), do not use alkaline (caustic) cleaning solutions for external engine cleaning. Alkaline solutions remove the alodine finish.
Remove dirt (especially caked dirt) and debris from bolts, nuts, and engine parts.	Do <u>not</u> use any of the following to clean the engine or parts: <ul style="list-style-type: none"> • Gasoline • Kerosene • Abrasive cleaning paste • Cleaning powder
Dispose of cleaning solvents in accordance with Environmental Protection Agency (EPA), or equivalent regulatory agency, regulations.	Do not scrape parts or use wire brushes, sandpaper, abrasive cloth or abrasive wheels unless specified in Table 12-1 to clean or polish parts to prevent concentrated stress to scratched areas and fatigue failure.
Dry blast only with plastic media or natural materials such as crushed walnut shells	Do not use sand, metal grit, or glass beads for any type of cleaning or dry blasting.
After a part is cleaned, machined or repaired, or if the alodine finish is worn, apply alodine to aluminum surfaces, according to instruction in Section 12-4.1.	



12-1.1. Cylinder Cleaning

CAUTION: When utilizing compressed air, wear OSHA approved safety glasses, goggles or face shield. Never exceed 30 psi when using compressed gases for cleaning purposes. (OSHA 1910.242(b))

1. Soak the engine cylinders in mineral spirits for 15 minutes. Dry the cylinder with compressed air. Verify the cylinder is free of dirt and deposits. If the cylinder is satisfactorily cleaned after a mineral spirit bath, proceed to step 4.
2. If caked on carbon deposits remain, remove oil and loose materials from engine cylinders by spraying or brushing on a mild alkaline cleaner.
 - a. Spray the cylinder with steam to remove all traces of alkaline residue.
 - b. After the cylinder dries, inspect it again for traces of alkaline residue; respray with steam if alkaline residue is still present (to prevent corrosion) and repeat step 1.
3. For persistent carbon, varnish and gum deposits, dry blasting may be required.
 - a. Seal and protect all machined surfaces on the cylinder such as the cylinder mount flange nut seats, barrel wall, small holes, and finished surfaces.

WARNING

Do not use sand, glass, shot or metal grit when dry blasting. These abrasives can damage engine components. This type of shot will become embedded in aluminum parts rendering them useless.

- b. Dry blast the cylinder to remove persistent carbon, varnish and gum deposits according to instructions in “Section 12-2, “Dry Blasting.”
 - c. Clean the cylinder with hot, soapy water and a stiff bristled (non-wire) scrub brush to remove blasting materials from the cylinder.
 - d. Thoroughly rinse the cylinder with hot water.
 - e. Wipe the cylinder bore with clean, soft white cloth and inspect cloth for cleaning debris. Repeat cleaning process until the cloth is free of debris.
 - f. Dry the cylinder completely.
4. Coat all bare steel surfaces thoroughly with clean, 50-weight aviation oil to prevent cylinder bore damage due to rust and contamination.



12-1.2. Piston Cleaning

CAUTION: When utilizing compressed air, wear OSHA approved safety glasses, goggles or face shield. Never exceed 30 psi when using compressed gases for cleaning purposes. (OSHA 1910.242(b))

1. Soak the piston in mineral spirits.
2. If carbon deposits do not yield to solvent and deposits remain, install a tight fitting skirt protector and dry blast the piston heads with soft grit or employ the vapor grit method (to clean the piston top). Refer to Section 12-2, "Dry Blasting." and Section 12-3, "Vapor Blasting."

WARNING

When dry blasting, do not use sand, glass, shot or metal grit which can damage engine components. This media will become embedded in aluminum parts rendering them unusable.

3. Clean the piston with hot, soapy water and a stiff bristled (non-wire) scrub brush to remove all blasting materials from the piston. Thoroughly rinse all soap residue from the piston and cylinder bore using hot water.

CAUTION: Do not use wire brushes or scrapers of any kind to clean the piston.

4. Clean the piston ring grooves by pulling lengths of binder twine or very narrow strips of crocus cloth through the grooves. Do not use automotive ring grooves scrapers; the corner radii at the bottom of the grooves and side clearances must not be altered. Do not use abrasive cloth on the piston skirts because the diameters and cam-ground contour must not be altered.
5. Discard scored or burned pistons.
6. After cleaning, thoroughly rinse pistons using a Stoddard solvent to remove all debris.



12-1.3. Cleaning Exhaust Parts

1. Clean the exhaust system parts (except for the multi-segment V-band clamps) with Stoddard solvent. Allow the solvent to drain and wipe the parts dry with a clean cloth.
2. Clean V-band clamps using crocus cloth on the outer band clamp assembly.

12-1.4. Cleaning Aluminum Alloy Parts

Degrease aluminum alloy parts with mineral spirits. Soak heavily soiled parts for 15 minutes in mineral spirits. To remove carbon and gum deposits, perform the following:

CAUTION: Do not use an alkaline etching solution.

1. Immerse the part in a hot bath of any of the following *long enough to remove the deposit*:
 - a. Inhibited, mild alkaline cleaning solution.
 - b. Hot, soapy water.
 - c. Carbon solvent (only for hard, thick carbon deposits).
2. Remove the cleaned part from the solvent bath.

CAUTION: Remove all solvent residue (especially if soap or mild alkaline cleaning solution is used), paying particular attention to crevices, recesses, and holes to prevent engine oil contamination on re-assembly. If not removed completely, the alkaline residue can corrode the part.

3. Rinse thoroughly to remove all traces of the cleaning solution.

CAUTION: When utilizing compressed air, wear OSHA approved safety glasses, goggles or face shield. Never exceed 30 psi when using compressed gases for cleaning purposes. (OSHA 1910.242(b))

4. Dry the part with dry compressed air.
5. If carbon deposits remain on the part, refer to Section 12-2, "Dry Blasting."
6. Remove protective seals and masking material.
7. If the Alodine finish was removed during cleaning, restore the alodine finish according to Section 12-4.1, "Alodine."



12-2. Dry Blasting

Dry blast cleaning entails aiming plastic pellets or processed natural materials, such as crushed walnut shells, under pressure toward an area to be cleaned. To clean using the dry blast method, perform the following procedure:

WARNING

Do not use sand, glass, shot or metal grit when dry blasting as this can damage engine components. This type of shot will become embedded in aluminum parts rendering them useless.

CAUTION: Mask machined surfaces, such as bearing saddles, lifter bores, and parting surfaces to avoid surface erosion or abrasion.

1. Prior to dry blasting any component, seal and protect all machined surfaces on the holes and finished surfaces.
2. Using plastic pellets or processed natural materials, such as crushed walnut shells, adjust blast pressure to the lowest setting that will produce the desired cleaning action and aim toward the paint, varnish, or carbon deposit.

CAUTION: When utilizing compressed air, wear OSHA approved safety glasses, goggles or face shield. Never exceed 30 psi when using compressed gases for cleaning purposes. (OSHA 1910.242(b))

3. Blow off all dust with dry, compressed air.
4. Verify that no blasting material has lodged in crevices, recesses, or holes.

12-3. Vapor Blasting

Vapor blasting is used in specific, limited applications such as piston tops. This vapor grit method of cleaning employs high-pressure steam and a very fine abrasive to remove heavy carbon deposits. Clean parts thoroughly after vapor blasting to remove all traces of the blast media.

CAUTION: Vapor blasting must not be used on bearing surfaces. Follow the equipment manufacturer's instructions when employing this type of cleaning.



12-4. Protective Coatings

Protective or anti-corrosive coatings include:

- Alodine
- Zinc chromate primer
- Enamel paint
- 50-weight aviation oil

Apply a protective coating after any machining or repairing aluminum surfaces with an aluminum conversion coating. Continental Motors recommends alodine, also known by the brand name Accelagold, to prevent corrosion on aluminum surfaces, see Section 12-4.1, "Alodine."

12-4.1. Alodine

Apply a protective coating of alodine to any of the following:

- Parts with aluminum surfaces that have been cleaned, machined, or repaired.
- Aluminum alloy castings
- Aluminum sheet metal
- Aluminum tubing

If the original aluminum conversion coating has been removed or deteriorated, it must be restored. Apply Alodine or Accelagold solution in accordance with the manufacturer's instructions. For Accelagold, refer to Technical Data Bulletin Number 108-31 Turcoat® Accelagold Aluminum Conversion Coating.

12-4.2. Aviation Oil

Apply clean 50-weight aviation oil to cleaned, machined steel surfaces.



12-4.3. Paint

1. Mask all connection joints and mating surfaces.
2. Clean the parts thoroughly with parts cleaning solvent to remove residue.
3. Determine the type of material the part is made of:
 - Aluminum parts are lightweight, non-ferrous, gray colored metal.
 - Steel and Iron parts are ferrous, meaning they respond to a magnet
 - Magnesium parts resemble aluminum; non-ferrous, gray colored metal. To differentiate between aluminum and magnesium, apply a few drop of vinegar to the bare metal at a non-critical location on the part, such as a casting datum locator; do not test at a mating surface. Aluminum will not react to vinegar, magnesium will oxidize (bubble) and release hydrogen gas at the application site. Rinse the part thoroughly to remove the vinegar residue.

CAUTION: Do not apply primer or enamel paint to internal engine parts or any part that contacts the engine oil supply. The paint or primer may flake or break off during engine operation and contaminate the engine oil.

4. Follow instructions in Table 12-3 for instructions to prepare and apply protective coatings to the exterior of the engine parts. Do not prime or paint internal parts or interior surfaces of the engine.

Table 12-3. Painting External Parts

Aluminum Parts	Ferrous Parts	Magnesium Parts
1. Apply alodine according to manufacturer's instructions 2. Apply enamel to the part.	1. Apply zinc chromate primer. 2. Apply enamel to the parts. 3. Bake for 15 minutes using infrared heat or oven-dry for 60 minutes at 275° to 300°F (135° to 149°C).	1. Chrome pickle the part (AMS M-3171) 2. Apply zinc chromate primer. 3. Apply enamel to the part. 4. Bake for 15 minutes using infrared heat or oven-dry for 60 minutes at 275° to 300°F (135° to 149°C).
		Through Hardened Cylinder Barrels Part No. 658601, or later 1. Apply zinc phosphate primer to cylinder barrel only and allow to dry. 2. Apply one coat black enamel to cylinder barrel. 3. Paint aluminum cylinder head according to aluminum parts instructions. 4. Bake primed and painted cylinders for 16 hours in 400°F oven.



Intentionally Left Blank



Appendix A. Glossary

A-1. Acronyms

The following acronyms are commonly used throughout Continental Motors publications.

Acronym	Definition
°C	degrees Celsius
°F	degrees Fahrenheit
Ω	ohm
A or Amp	Ampere
A & P	Airframe & Power-plant
AD	Airworthiness Directive
AFM	Airplane Flight Manual
AO	Authorized Oversize
APU	Auxiliary Power Unit
AR	As Required
AU	Authorized Undersize
BHP	Brake Horsepower
BSOC	Brake Specific Oil Consumption
BTC	Before Top Dead Center
CFM	Cubic Feet per Minute
CHT	Cylinder Head Temperature
CSB	Critical Service Bulletin
DMM	Digital Multimeter
DVM	Digital Volt-ohm Meter
EGT	Exhaust Gas Temperature
EMI	Electromagnetic Interference
ft	foot
ft. lbs.	foot pounds
FAA	Federal Aviation Administration
FAR	Federal Aviation Regulations
FBO	Fixed Base Operator
g	gram
gal	US gallon
gph	gallon per hour



Glossary

Acronym	Definition
HP	Horsepower
IAW	In accordance with
ICA	Instructions for Continued Airworthiness
in.	Inch
in. Hg	Inches of Mercury
in. lbs.	Inch Pounds
kg	kilogram
kPa	kilopascal
kW	kilowatt
L	liter
lb.	pound
m	meter
mm	millimeter
MAP	Manifold Air Pressure
MAT	Manifold Air Temperature
MEK	Methyl Ethyl Ketone
MHS	Material Handling Specifications
MJ	Main Journal
MSB	Mandatory Service Bulletin
OAT	Outside Air Temperature
OD	Outside Diameter
OEM	Original Equipment Manufacturer
NATO	North Atlantic Treaty Organization
Nm	Newton meter
POH	Pilot's Operating Handbook
PMA	Parts Manufacturing Approval
ppm	parts per million
psi	pound per square inch
RMS	Root Mean Square
RPM	Revolutions per Minute
SB	Service Bulletin
SID	Service Information Directive



Acronym	Definition
SIL	Service Information Letter
STANAG	Standardization Agreement (STANAG)
STC	Supplemental Type Certificate
TBO	Time Between Overhauls
TC	Type Certificate
TDC	Top Dead Center
TIT	Turbine Inlet Temperature
TSO	Technical Standard Order
TSMOH	Time Since Major Overhaul
WOT	Wide Open Throttle

A-2. Terms and Definitions

Term	Definition
Alternate Air System	Should the inlet to the Air Induction system become blocked, the alternate air system is designed to open providing air flow into the engine cylinders to prevent air starvation.
Airworthiness Approval Tag	FAA Tag 8130-3 that identifies a part or group of parts that has been deemed airworthy by an authorized FAA representative.
Aneroid Metering Rod	This rod is positioned by the aneroid and regulates fuel pump output pressure based on ambient pressure or turbocharger discharge pressure.
Burning	In reference to the engine valves, indicates roughening or erosion due to high temperature gases escaping past valve faces. In other instances, it indicates drawing of the temper of steel parts to a soft (blue) condition, as a result of overheating, during an absence of lubrication on moving surfaces, such as gear teeth subject to high loading.
Burr	Sharp or rough projection of metal.
Chafing	Condition caused by a rubbing action between adjacent or contacting parts under light pressure which results in wear.
Crack	Partial separation of material usually caused by vibration, overloading, internal stresses, improper assembly, or fatigue.
Critical Service Bulletin	Service document based on determination by the product manufacturer to constitute a threat to continued safe operation of an aircraft or to persons or property on the ground unless the owner or operator takes some specific action (inspection, repair, replacement, etc.). Documents in this category are candidates for incorporation into an Airworthiness Directive issued by the FAA.



Glossary

Term	Definition
Dent	Rounded depressed, pushed-in area on a surface.
Dynamic Seal	Vital seal in the engine cylinder that consists of valve-to-valve seat seals, spark plug-to-spark plug port seals, and cylinder head-to-barrel seal.
Elongate	To stretch out or lengthen.
Erosion	Wearing away of material due to flow, hot gases, grit, or chemicals.
Fretting	Surface erosion caused by slight movement between two parts that are fastened together.
Fuel Control Unit	A mechanically controlled valve that meters the amount of fuel based on throttle position.
Fuel Manifold Valve	A device that distributes metered fuel flow to the individual cylinder fuel injector nozzles. It also serves as a positive idle cut-off valve whenever the engine is shut down.
Fuel Metering Unit	Controls the amount of fuel flow to the Manifold valve assembly based on throttle position.
Fuel Pressure Regulator	A device that regulates full power fuel pressure without restricting maximum fuel pressure at lower power settings.
FULL RICH	Position of the mixture control that is required for Take off and full power settings. This setting provides the maximum ratio of parts fuel to parts air. (See Mixture Control)
Galling	Severe chafing or fretting that results in transfer of metal from one part to another; usually caused by slight movement of mated parts that have limited relative motion and are under heavy loads.
Grooved Surface	Shallow channels, deeper than scratches and usually smooth resulting from wear affected by concentrated contact stress.
Hot Weather	Ambient temperature exceeding 90°F (32°C)
Hydraulic Lock	Condition where fluid accumulates in the induction system or the cylinder assembly. The liquid restricts the piston from traveling during the compression stroke. Damage to the engine occurs when the other cylinders fire, which forces the piston in the fluid-filled cylinder through the compression stroke. Damage to an engine from hydraulic lock can be extensive due to the extreme stress load and can adversely affect connecting rods, pistons, cylinder assemblies, piston pins, the crankcase, and the crankshaft.
Idle Cut-off	Position of the mixture control that will virtually shut off the flow of fuel to the engine. (See Mixture Control)
Mandatory Service Bulletin	Service document relating to known or suspected hazards to safety that have been incorporated in whole or in part into an Airworthiness Directive (AD) issued by the FAA, or have been issued at the direction of the FAA by the manufacturer requiring compliance with an already-issued AD (or an equivalent issued by another country's airworthiness authority).



Term	Definition
Naturally Aspirated	A non boosted engine. Utilizes atmospheric pressure for combustion.
Nick	Sharp-sided gouge or depression with a V-shaped bottom.
Peening	Series of blunt depressions in a surface.
Pitting	Formation of pockets of corrosion products on the surface of a metal.
Propeller Strike	Any incident that requires repair (other than minor dressing of the blade) to a propeller blade. Either the propeller strikes an object or an object strikes the propeller and causing a propeller imbalance. Propeller strikes are serious because they can result in engine failure. Even if the propeller still continues to rotate, other components critical to engine operation may be damaged.
Runout	Eccentricity or wobble of a rotating part; eccentricity of two bored holes or two shaft diameters; a hole or bushing out of square with a flat surface. Runout is usually measured with a dial indicator, and limits stated indicate full deflection of indicator needle in one revolution of part or indicator support.
Scoring	Deep grooves in a surface caused by abrasion from fine hard particles wedged between moving surfaces, as in a bearing and journal, or caused by galling when a moving part is not supplied with lubricant.
Service Bulletin	Service document that contains information considered by the product manufacturer to constitute a substantial improvement to the inherent safety of an aircraft or component of an aircraft; also includes updates of instructions for continued airworthiness.
Service Information Directive	Service document that contains information determined by the manufacturer to be of value to an owner/operator in the use of a product by enhancing safety, maintenance, or economy.
Service Information Letter	Service information document may be useful to the owner/operator/technician. May contain updates to Instructions for Continued Airworthiness for optional component installations, which are not covered in the Applicable Operator, Maintenance, or Overhaul Manuals.
Spalling	Distress to a loaded surface where chips of the hardened surface are broken out.
Static Seal	Cylinder seal that consists of the piston rings to the cylinder wall seal.
Technical Standard Order	FAA-designated number and identification mark indicating that the part or appliance meets applicable design standards and was manufactured in accordance with the requirements of FAR 21 Subpart O.
Throttle	The air throttle controls the flow of air to the engine, depending on the position of the throttle control lever in the aircraft cockpit. Fuel control units are attached to the throttle control to permit the flow of fuel to be controlled as the throttle controls the airflow.



Glossary

Term	Definition
Thru Bolt (Thru-Bolt)	aka Through Bolt
Unmetered Pressure	Pressure of the fuel in pounds per square inch (PSI) at the outlet of the engine driven fuel pump or inlet of the fuel control unit.
Upper Deck Pressure	Upper Deck Pressure is also referred to as turbocharger compressor discharge pressure. This is the pressure in inches of mercury in the induction system after the turbocharger compressor and before the throttle plate.



Appendix B. Torque Specifications

B-1. General Information

NOTE: For TIARA engines, refer to the primary ICA (Section 1-1.1) for torque specifications.

Tables in this appendix list torque values for Continental Motors engine hardware. For aircraft or engine accessory torque specifications, refer to the aircraft or accessory manufacturer's instructions.

Table B-1. Appendix B, Quick Table Reference

Table Number and Title	Page No.
Table B-2. Component Specific Torque Specifications ¹	B-6
Table B-3. Specific Torque Specifications (Non-Lubricated Hardware) ²	B-13
Table B-4. FADEC Components (Non-Lubricated Hardware) ²	B-13
Table B-5. General Torque Specifications (for bolts, nuts, screws, driving studs, and pipe plugs)	B-14
Table B-6. Hydraulic Line Torque Specifications	B-14
Table B-7. Straight Thread Fitting Torque Specifications ³	B-15
Table B-8. Hose Fitting ("B" Nut) Torque Specifications	B-15

1. Torque values provided in Table B-1 must be used for the listed applications.
2. Table B-2 and Table B-3 lists specific "non-standard" torque values.
3. Table B-6 includes tube fittings.

WARNING

Torque values listed are for use with clean 50 weight aviation engine oil applied to the threads, unless otherwise specified in Table B-3 or Table B-4, which list torque specifications for non-lubricated hardware.

Confirm items identified in Appendix C-2.3, "100% Parts Replacement Requirements" or Appendix C-2.4, "Mandatory Overhaul Replacement Parts"(at overhaul) are replaced prior to assembly. Prior to torquing any hardware, unless otherwise specified, apply SAE 50 weight aviation oil to hardware listed in Table B-5 through Table B-8. If an application is not listed in the specific torque limits tables (Table B-2 through Table B-4), use the general torque limits in Table B-5 through Table B-8.

WARNING

Proper torquing practices cannot be over emphasized. Torque procedures are provided to achieve correct preloading of fasteners. If the fasteners are not properly plated, the fastener threads are not clean and free of deformation or are not properly lubricated, the correct fastener preload will not be achieved even though the given torque value is reached. For this reason, it is critical that all fasteners be inspected for proper plating, thread form, and correctly lubricated prior to torquing. Failure to



verify a fastener's serviceability or to correctly lubricate the fastener prior to assembly and torquing will result in the fastener not being properly preloaded and subsequent failure of the fastener may occur.

B-1.1. Torque Tips

WARNING

Do not apply any form of sealant to the crankcase cylinder deck, chamfer, cylinder mounting flange, cylinder base O-ring, or cylinder fastener threads. The use of RTV, silicone, Gasket Maker or any other sealant on the areas listed above during engine assembly will cause a loss of cylinder deck stud or through-bolt torque. Subsequent loss of cylinder attachment load, loss of main bearing crush and/or fretting of the crankcase parting surfaces will occur. The result will be cylinder separation, main bearing movement, oil starvation and catastrophic engine failure. USE ONLY CLEAN 50 WEIGHT AVIATION ENGINE OIL ON SURFACES LISTED.

- Check Table B-2 and Table B-4 first to determine if the hardware to be torqued requires a specific torque or treatment other than those for general torque specifications listed in Table B-5 through Table B-8.
- Before installing hardware, verify the fastener size is correct.
- The accuracy of any torque indicating wrench depends on a smooth application of force and current calibration traceable to the National Institute of Standards and Technology (NIST), verifiable by the calibration data label affixed to the tool.
- If cotter pin holes must be aligned, set the torque wrench at the low limit and tighten the nut to the first hole beyond this torque, but do not exceed the maximum specified torque limit. This torquing procedure must be followed for all applications requiring cotter pin hole alignment except for connecting rod nuts.
- If a nut slot cannot be aligned with a cotter pin hole within the specified limits, substitute another serviceable nut to attain alignment.
- If the cotter pin hole in a stud lies beyond the nut slots, when the nut has been torqued properly, check the stud for proper installation or for backing out.
- Check studs for necking damage (over stretch/misshapen deformity) due to excessively applied torque.
- Check the part for reduced thickness resulting from wear or incorrect part.
- Where applicable, special instructions/details are provided in footnotes following each table.
- The notation (AR) refers to “As Required” in all torque specification tables.



B-2. Part Supersedure

1. Through bolt nuts Part Nos. 634505 and 649496 have been superseded by nut Part Number 652541. At engine overhaul, all Part Number 634505 and 649496 flanged through bolt nuts must be replaced with Part Number 652541 (flanged 12 point nut).

NOTE: If replacing Part Number 634505 or 649496 (less that a complete set, prior to engine overhaul), torque the replacement nut Part Number 652541 to the required valve of the original fasteners (Part Number 634505 or 649496).

- a. Nut, Part Number 634505 is a flanged 6 point (hex) nut requiring a torque value of 690-710 inch lbs.
 - b. Nut, Part Number 649496 is a flanged 6 point (hex) nut requiring a torque value of 790-810 inch lbs.
 - c. Nut, Part Number 652541 is a flanged 12-point nut requiring a torque value of 790-810 inch lbs.
2. Connecting Rods
 - a. Nut, Connecting Rod (nut Part Number 626140 w/bolt Part Number 35972) is superseded by Nut, Connecting Rod (Spiralock nut Part Number 654487 w/bolt Part Number 655960).
 - b. Nut, Connecting Rod (nuts 24804 or 626140 w/bolt Part Number 530213) and Nut, Connecting Rod (Spiralock nut Part Number 654487 w/bolt Part Number 654693) are superseded by Nut, Connecting Rod (Spiralock nut Part Number 654487 w/bolt Part Number 655959).



B-3. Torque Wrench and Extension Calculations

Torque wrenches measure the force applied to the fastener on the axis of the square drive socket adapter.

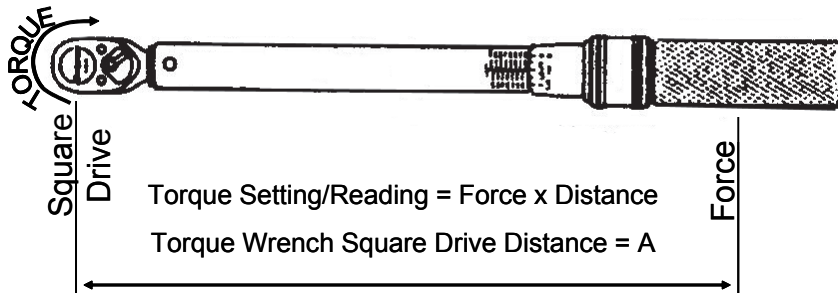

Figure B-1. Torque Wrench

Straight extensions and wobble extensions up to 15 degrees, which extend the square drive length, do not alter the amount of force applied to the square drive enough to cause concern. An offset adapter may be used with a torque wrench without affecting applied torque if the extension is positioned at a 90 degree angle in relation to the square drive adapter. In any other orientation, the extension alters the force applied to the fastener.

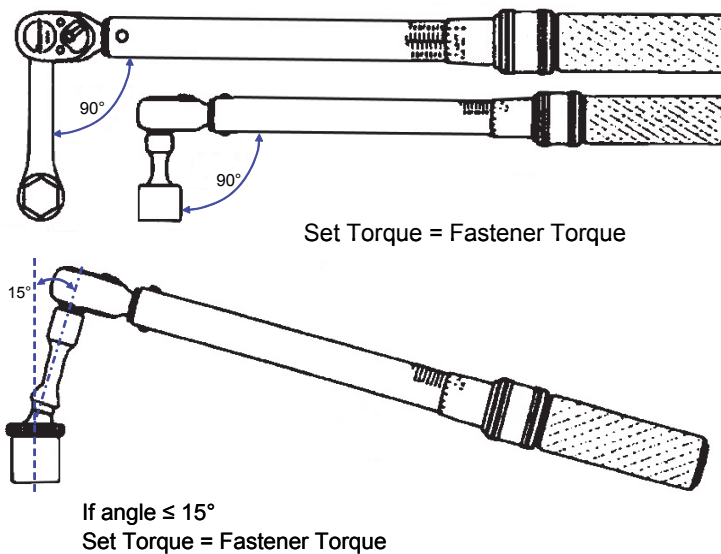

Figure B-2. Drive extensions

Apply the formula below to determine the appropriate torque wrench setting when using an extension:

$$S = \frac{T}{A + B} \times A$$

Where:

S = desired torque setting or reading

T = torque applied at square drive adapter

A = length of handle in inches

B = length of extension in inches

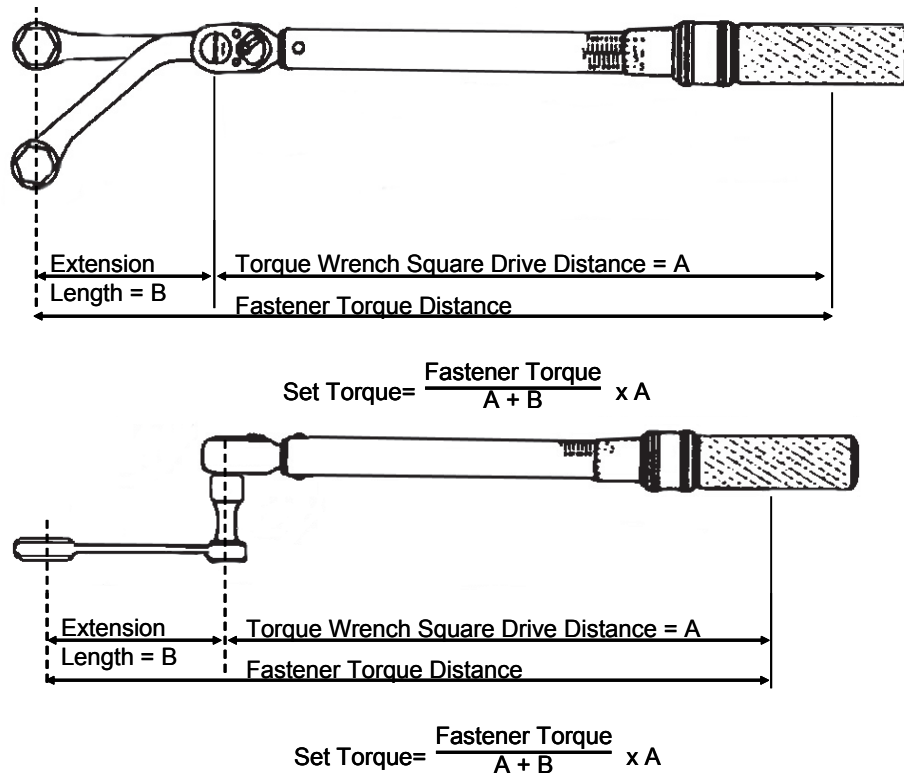

Figure B-3. Extension increases applied torque

Examples in Figure B-3 and Figure B-4 illustrate how extensions can alter the torque applied at the fastener. The example in Figure B-3 adds the length of the extension to the torque wrench, increasing the leverage applied to the fastener. The position of the extension in Figure B-4 reduces the effective length of the handle and the applied leverage. Variable B (length of the extension) is subtracted from variable A in Figure B-4.

Let's assume the torque wrench has an effective length of 12 inches and the extension measures six inches from the center of the drive adapter to the center of the wrench. If we need to torque a nut and bolt to 45 inch-pounds, we set the dial on the wrench in Figure B-3 to 30 ($45 \div (12+6) \times 12$). The same torque wrench, used with the extension in Figure B-4 must be set to 90 ($45 \div (12-6) \times 12$) to apply 45 inch pounds of torque to the same nut and bolt.

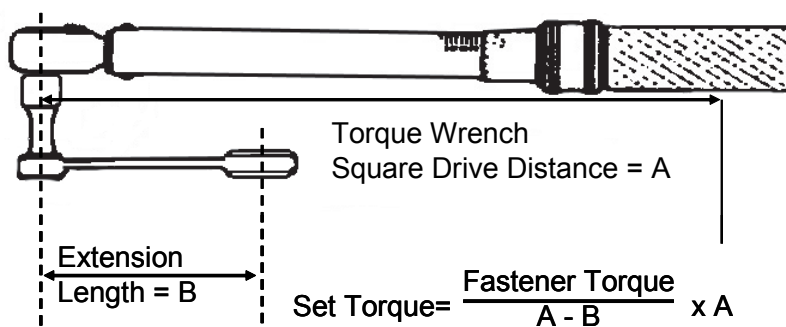

Figure B-4. Extension decreases applied torque



Torque Specifications

Table B-2. Component Specific Torque Specifications

Size	Fastener	Torque Value		Models Affected (Non-standard, see General Torque Specification)
		In.-Lbs.	Ft.-Lbs.	
Crankcase				
.25-28	Nut, Crankcase Flange	100-125	8.3-10.4	A, C, & E Series, O-200, O-300, O-470 (AR), IO-240 & IOF-240
.25-28	Nut, Engine Mount Leg Bushing	90-100	7.5-8.3	C-125, C-145 & O-300
.25-28	Nut, Tie Bolt Prop Shaft Cages	90-110	7.5-9.2	GO-300
.31-18	Bolt, Oil Sump Flange	155-175	12.9-14.6	IO-346, O-470, IO-470, TSIO-470, GTSIO-520, IO-520, L/TSIO-520, IO-550, IOF-550, TSIO-550, TSIOF-550 & TSIOL-550
.31-24	Nut, Crankcase Flange	180-220	15.0-18.3	IO-346, O-470, IO-470, TSIO-470, GTSIO-520, IO-520, L/TSIO-520, IO-550, IOF-550, TSIO-550, TSIOF-550 & TSIOL-550
.31-24	Nut, Crankcase Backbone	240-280	20.0-20.3	(AR) Stainless Steel Hardware Only
.31-24	Nut, Crankcase Through Bolts	180-220	15.0-18.3	O-470 (AR), & E Series
.31-24	Nut, Magneto to Crankcase	100-120	8.3-10.0	All Models (AR)
.31-24	Nut, Magneto Gearshaft Support to Crankcase, ConeLok	190-210	15-8-17.5	IO-360 & L/TSIO-360
.31-24	Nut, Self-Locking, Fuel Pump Cover	155-175	12.9-14.6	O-200-A, B & D; O-300-A & D
.38-24	Bolt, Crankcase Through Bolts, Front Main Only	275-325	22.9-27.1	GO-300
.38-24	Nut, Crankcase Through Bolts, Front	370-390	30.8-32.5	O-470 & E Series
.38-24	Nut, Crankcase Through Bolts, Upper Rear	275-325	22.9-27.1	All 470, 520 & 550
.38-24	Nut, Crankcase Through Studs	275-325	22.9-27.1	A Series, C-75, C-85, C-90 & O-200
.38-24	Nut, Crankcase Tie Bolts	370-390	30.8-32.5	All (AR) EXCEPT IO-240, IOF-240 & 360
.38-24	Nut, Crankcase Tie Bolts	275-325	22.9-27.1	All IO-240, IOF-240, & 360
.38-24	Nut, Cylinder to Crankcase Stud	410-430	34.2-35.8	A, C, & E Series, O-200, O-300, GO-300 & O-470
.38-24	Nut, Cylinder to Crankcase Studs	440-460	36.7-38.3	All IO-240, IOF-240, & 360
.38-24	Nut, Mounting Bracket to Crankcase	275-325	22.9-27.1	All Models (AR)
.44-20	Nut, Crankcase Tie-Bolts-Nose & Below Camshaft	440-460	36.7-38.3	All Models (AR)
.44-20	Nut, Cylinder to Crankcase Studs (includes 7th stud)	490-510	40.8-42.5	All Models EXCEPT TSIOL-550
.44-20	Nut, Cylinder to Crankcase Studs	590-610	49.2-50.8	TSIOL-550



Table B-2. Component Specific Torque Specifications

Size	Fastener	Torque Value		Models Affected (Non-standard, see General Torque Specification)
		In.-Lbs.	Ft.-Lbs.	
.44-20	Nut, Cylinder to Crankcase Through Studs	400-450	33.3-37.5	A Series, C-75, C-85 & C-90
.44-20	Nut, Front & Rear Crankcase Bearing Through Studs	490-510	40.8-42.5	O-200
.44-20	Nut, Through Bolt at Cadmium Plated Washer	440-460	36.7-38.3	All Models (AR)
.44-20	Nut, Through Bolt at Cylinder Flange	490-510	40.8-42.5	All (AR) EXCEPT IO-240, IOF-240, & 360
.44-20	Nut, Through Bolt at Cylinder Flange	590-610	49.2-50.8	All IO-240, IOF-240, & 360
.44-20	Nut, Through Bolt at Front Mount Belt-Driven Alternator	490-510	40.8-42.5	All Models (AR)
.44-20	Nut, Tie Bolts at Nose and Prop Shaft Cages	340-360	28.3-30.0	GO-300
.50-20	Nut, Crankcase Through Bolt at Cadmium Plated Washer	615-635	51.2-52.9	IO-346, O-470, IO-470, TSIO-470, GTSIO-520, IO-520, L/TSIO-520, IO-550, IOF-550, TSIO-550, & TSIOF-550
.50-20	Nut, Crankcase Through Bolt at Cylinder Flange, P/N 634505 (6 point/0.33" tall)	690-710	57.5-59.2	All IO-346, All 470, All 520 & All 550 EXCEPT TSIOL-550
.50-20	Nut, Crankcase Through Bolt at Cylinder Flange, P/N 652541 (12 point)	790-810	65.8-67.5	All IO-346, All 470, All 520 & All 550 EXCEPT TSIOL-550
.50-20	Nut, Crankcase Through Bolt at Cylinder Flange, P/N 649496 (6 point/0.43" tall)	790-810	65.8-67.5	TSIOL-550
.50-20	Nut, Crankcase-Nose Tie Bolts	640-660	53.3-55.0	All Models (AR)
.50-20	Nut, Through Bolt at Cadmium Plated Washer	690-710	57.5-59.2	TSIOL-550
.62-18	Plug, (using crush washer)	190-210	15.8-17.5	All Models (AR)
Gears				
.25-28	Bolt, Gear to Camshaft	140-160	11.7-13.3	A, C & E Series, O-200, O-300, O-470, IO-240, & IOF-240
.25-28	Bolt, Gear to Crankshaft (P/N 22532) ¹	140-160	11.7-13.3	A, & C Series, O-200, O-300, GO-300, IO-240 & IOF-240
.25-28	Bolt, Gear to Crankshaft (P/N 534904) ¹	170-175	14.2-14.6	E Series, O-470 Numerical, O-470-A & E
.31-24	Bolt, Gear to Camshaft	240-260	20.0-21.7	E Series, IO-360, L/TSIO-360, IO-346, O-470, IO-470, TSIO-470, GTSIO-520, IO-520, L/TSIO-520, IO-550, IOF-550, TSIO-550, TSIOF-550, & TSIOL-550
.31-24	Bolt, Gear to Crankshaft (Lower Hardness Identified with Green Dykem) ¹	240-260	20.0-21.7	E Series, IO-360, L/TSIO-360, IO-346



Torque Specifications

Table B-2. Component Specific Torque Specifications

Size	Fastener	Torque Value		Models Affected (Non-standard, see General Torque Specification)
		In.-Lbs.	Ft.-Lbs.	
.31-24	Bolt, Gear to Crankshaft (Bolt Hardness RC 38-42) ¹	380-420	31.7-35.0	O-470, IO-470, TSIO-470, IO-520, L/TSIO-520, GTSIO-520, IO-550, IOF-550, TSIO-550, TSIOF-550, & TSIOL-550
.31-24	Bolt, Face Gear to Camshaft	140-150	11.7-12.5	IO-346, GTSIO-520, IO-520, TSIO-520 (AR), IO-550, IOF-550, TSIO-550, & TSIOL-550
.31-24	Nut, Generator or Alternator Gear	175-200	14.6-16.7	A, C & E Series, O-200, IO-240, O-300, GO-300, IO-360, & L/TSIO-360
.31-24	Nut, Generator Gear (531231) w/washer (401507)	175-195	14.6-16.3	E Series
.38-24	Bolt, Vacuum & Fuel Pump Gear to Camshaft	275-325	22.9-27.1	IO-240 & IOF-240
.38-24	Nut, Slick Mag Gear to Magneto Shaft	120-180	10.0-15.0	O-200 & O-300
Connecting Rods				
.38-24	Nut, Connecting Rod (nuts 24804 or 626140 w/bolt P/N 530213) ^{2, 3, 4}	400-475	33.3-39.6	A & C Series, O-200, O-240, IO-240, IOF-240, O-300, GO-300, IO-360 & L/TSIO-360
.38-24	Nut, Connecting Rod (Spirallock nut P/N 654487 w/bolt P/N 655960)	400-475	33.3-39.6	E-Series O-470, IO-470, with 654796 Connecting Rod
.38-24	Nut, Connecting Rod (nut P/N 626140 w/bolt P/N 35972) ^{2, 3, 5}	400-475	33.3-39.6	E-185, E-205, E-225, IO-346, O-470 Numbered and Lettered Engines IO-470, TSIO-470, with 628751 Connecting Rod
.38-24	Nut, Connecting Rod (Spirallock nut P/N 654487 w/bolt P/N 654693) ⁵	490-510	40.8-42.5	O-200, O-240, IO-240, IOF-240, O-300, IO-360, L/TSIO-360, O-470, IO-470, TSIO-470
.38-24	Nut, Connecting Rod (Spirallock nut P/N 654487 w/bolt P/N 655959)	490-510	40.8-42.5	O-200, O-240, IO-240, IOF-240, O-300, IO-360, L/TSIO-360, O-470, IO-470, TSIO-470
.44-20	Nut, Connecting Rod (Spirallock nut P/N 643215 w/bolt P/N 643112)	550-600	45.8-50.0	O-470, IO-470, IO-520, L/TSIO-520-AE & CE, IO-550, IOF-550, TSIO-550, TSIOF-550 & TSIOL-550
.44-20	Nut, Connecting Rod (Spirallock nut P/N 654490 w/bolts P/N 643112 or P/N 655958)	690-710	57.5-59.2	O-470, IO-470, GTSIO-520, IO-520, L/TSIO-520, IO-550, IOF-550, TSIO-550, TSIOF-550 & TSIOL-550
.44-28	Nut, Connecting Rod (rod P/N 646476 w/bolts P/N 629340 and nut 628109) ²	475-525	39.6-43.8	IO-346, O-470, IO-470, TSIO-470, IO-520 & TSIO-520 (EXCEPT L/TSIO-520-AE & CE)
.44-28	Nut, Connecting Rod (rod P/N 646474 w/bolts P/N 631794 and nut 631554) ²	550-575	45.8-47.9	GTSIO-520



Table B-2. Component Specific Torque Specifications

Size	Fastener	Torque Value		Models Affected (Non-standard, see General Torque Specification)
		In.-Lbs.	Ft.-Lbs.	
Miscellaneous Fuel Injection				
#8-32	Screw, Aneroid Body Hold Down (AN500-8-14)	17.5-22.5	1.5-1.9	All Fuel Injected Model (AR)
#8-32	Screw, Manifold Cover Hold Down (AN503-8-12)	22-26	1.8-2.2	All Fuel Injected Model (AR)
.125-27	Fitting, Cover, Fuel Pump, Vapor Separator	60-80	5.0-6.7	All Fuel Injected Model (AR)
.125-27	Nozzle, Fuel Injector (w/anti-seize compound)	55-65	4.6-5.4	All Fuel Injected Model (AR)
.19-24	Through Bolt, Fuel Pump	29-31	2.4-2.6	All Fuel Injected Model (AR)
.25-28	Ejector, Cover, Fuel Pump, Vapor Separator	90-100	7.5-8.3	All Fuel Injected Model (AR)
.25-48	Jam Nut, Aneroid Stem Adjustment	25-30	2.1-2.5	All Fuel Injected Model (AR)
.31-24	Nozzle, Fuel Injector (w/anti-seize compound)	55-65	4.6-5.4	All Fuel Injected Model (AR)
.31-24	Nut, Throttle and Mixture Control Levers to Shaft	100-120	8.3-10.0	All Fuel Injected Model (AR)
.31-32	Nut, Fuel Injection Line	40-45	3.3-3.7	All Fuel Injected Model (AR)
.38-24	Nut, Fuel Injection Line	55-60	4.6-5.0	All Fuel Injected Model (AR)
.50-24	Nut, Air Reference Sleeve "B" Nut to Air Reference Line ⁶	--	--	All Turbocharged Models
.62-18	Metering Unit Plug & Screen Assembly (w/new gasket)	120-130	10.0-10.8	All Fuel Injected Model (AR)
Miscellaneous Lubrication System Fasteners				
.25-20	Bolt, Oil Cooler to Adapter	100-110	8.3-9.2	IO-360, L/TSIO-360, O-470, IO-470, TSIO-470, IO-520, TSIO-520 (AR), IO-550, IOF-550, TSIO-550, TSIOF-550 & TSIOL-550
.25-20	Bolt, Oil Pump Cover to Crankcase	75-85	6.3-7.1	All Models (AR)
.25-28	Nut, Collar Assembly - Governor Oil Transfer	75-85	6.3-7.1	O-470, IO-470, TSIO-470, IO-520, TSIO-520 (AR), IO-550, IOF-550, TSIO-550, TSIOF-550 & TSIOL-550
.375-18	Oil Cooler Cross Fitting ⁷	185 min.	15.4 min.	TSIO-550-C, K, N; TSIOF-550-D, K
.38-24	Tachometer, Shaft to Oil Pump Drive Gear	280-300	23.3-25.0	IO-360-D, L/TSIO-360
.62-18	Plug, Bypass Valve	190-210	15.8-17.5	O-200-D
.62-18	Plug, Oil Cooler (w/crush washer)	190-210	15.8-17.5	All Models (AR)
.62-18	Plug, Oil Suction Tube (w/crush washer)	190-210	15.8-17.5	All Models (AR)
.62-18	Plug, Oil Sump Drain	190-210	15.8-17.5	All Models (AR)



Torque Specifications

Table B-2. Component Specific Torque Specifications

Size	Fastener	Torque Value		Models Affected (Non-standard, see General Torque Specification)
		In.-Lbs.	Ft.-Lbs.	
.62-18	Oil Filter Cartridge	180-216	15.0-18.0	All Models (AR)
.75-16	Oil Filter, Disposable	192-216	16.0-18.0	All Models (AR)
.75-16	Plug, Oil Sump Drain	190-210	15.8-17.5	IO-470-M & IO-520-E
.88-16	Cap, Oil Relief Valve	190-210	15.8-17.5	O-200, IO-240, IOF-240, O-300 & L/TSIO-360
.88-16	Plug, Oil Bypass	240-260	20.0-21.7	O-470, IO-470, TSIO-470, IO-520, TSIO-520, GTSIO-520, IO-550, IOF-550, TSIO-550, TSIOF-550 & TSIOL-550
1.00-14	Vernatherm, Oil Temperature Control Valve ⁸	190-210	15.8-17.5	All Models (AR)
1.00-18	Screen Assembly, Scavenge Oil	200-210	16.7-17.5	O-300 (AR), IO-360 (AR), L/TSIO-360 (AR)
1.12-18	Housing, Oil Pressure Relief Valve (New Gasket)	240-260	20.0-21.7	IO-346, O-470, IO-470, TSIO-470, IO-520, TSIO-520, GTSIO-520, IO-550, IOF-550, TSIO-550, TSIOF-550 & TSIOL-550
1.25-18	Plug, Special Vernatherm	310-320	20.8-29.2	IO-470, O-470, IO-520, IO-550, L/TSIO-520, IOF-550
1.25-18	Vernatherm, Oil Temperature Control Valve ⁸	410-420	34.2-35.0	All Models (AR)
1.375-16 LH	Housing, Tachometer Drive	250-350	20.8-29.2	All Models (AR)
1.75-16	Oil Filter Adapter Lock Nut	500-520	41.6-43.3	O-300 (AR), IO-360 (AR) & L/TSIO-360 (AR)
1.75-16	Oil Filter Screen (w/new crush gasket. Install gasket w/parting line against screen face.)	500-520	41.6-43.3	All Models (AR)
Miscellaneous Cylinder Hardware				
.071 (18mm)	Spark Plug ⁹	300-360	25.0-30.0	All Models (AR)
.125-27	Connector, Cylinder Drain	60-80	5.0-6.7	All Models (AR)
.19-32	Screw, Cylinder Baffle to Baffle Support ¹⁰	--	--	All Models (AR)
.19-32	Screw, Cylinder Baffle to Baffle Base	36-50	3.0-4.2	All Models (AR)
.25-20	Bolt, Rocker Shaft Hold Down	85-110	7.1-9.2	O-470-2, 4, 13, 13A & O-470-B (AR)
.25-20	Bolt, Through Bolted Rocker Shaft	90-100	7.5-8.3	O-470, IO-470, TSIO-470, IO-520, TSIO-520 (EXCEPT BE), IO-550 (EXCEPT G, N, P & R), IOF-550 (EXCEPT N, P & R) & TSIOL-550
.25-20	Screw, Rocker Box Cover (tighten two lower screws first)	55-65	4.6-5.4	IO-240, IOF-240, IO-360 & L/TSIO-360
.25-20	Screw, Rocker Cover	55-65	4.6-5.4	All Models (EXCEPT 240 & 360)
.25-20	Screw, Intake Flange	85-110	7.1-9.2	All Models (AR)
.25-20	Set Screw, Rocker Shaft, Locking	45-55	3.8-4.6	O-200, O-300



Table B-2. Component Specific Torque Specifications

Size	Fastener	Torque Value		Models Affected (Non-standard, see General Torque Specification)
		In.-Lbs.	Ft.-Lbs.	
.25-28	Nut, Rocker Shaft Hold Down	110-120	9.2-10.0	IO-240, IOF-240 & All 360
.25-28	Nut, Exhaust (self locking)	120-130	10.0-10.8	All Models (AR)
.25-28	Nut, Exhaust Manifold Flange (spiralallic gasket)	100-110	8.3-9.2	All Models (AR)
.31-18	Bolt, Rocker Shaft Hold Down ¹¹	190-210	15.8-17.5	GTSIO-520, TSIO-520-BE, IO-550-G, N, P & R, IOF-550-N, P & R, TSIO-550 & TSIOF-550
.31-24	Bolt, Rocker Shaft Hold Down ¹²	85-110	7.1-9.2	O-470, IO-470, TSIO-470, IO-520, TSIO-520 (EXCEPT BE), IO-550 (EXCEPT G, N, P & R), IOF-550 (EXCEPT N, P & R) & TSIOL-550
.31-24	Nut, Exhaust Manifold Flange (spiralallic gasket)	200-210	16.7-17.5	All Models (AR)
.31-24	Nut, Induction Tube Flange	50-70	4.2-5.8	IO-240, IOF-240 & All 360
.44-20	Plug, Cylinder Drain (w/O-ring)	50-70	4.2-5.8	TSIOL-550
Miscellaneous Fasteners				
.19-32	Nut, Carburetor Air Intake Box Control Lever	9-10	0.75-0.83	O-200-D
.25-62	Clamp, Hose, Oil Gauge Rod	12-16	0.3-1.3	IO-360 & L/TSIO-360 (AR)
.25-62	Clamp, Hose, Magneto Pressurization	10-14	0.8-1.17	All Models with Pressurized Magnetos
.25-28	Nut, Exhaust Coupling, "V" band clamp ¹³	42	3.5	TSIO-520-L, LB & WB
.31-18	Bracket, Turbocharger	220-250	18.3-20.8	GTSIO-520-F, K
.31-18	Bolt, Alternator Mounting	150-180	12.5-15.0	IO-346, All 520 & All 550
.38-16	Bolt, Turbocharger to Bracket	310-350	25.8-29.2	TSIO-520-L1, LB, UB, WB
.38-24	Nut, Slick Mag Impulse Coupling to Magneto Shaft	120-180	10.0-15.0	All Model using Slick Impulse Coupled Magnetos
.38-24	Nut, Starter to Adapter	200-220	16.7-18.3	O-300 (AR), GO-300 (AR), IO-346, All 470, 520 & 550
.44-20	Nut, Alternator Sheave to Starter Shaft	600-720	50-60	TSIO-520-B
.56-18	Nut, Starter Shaft Gear ¹⁴	450-500	37.5-41.6	IO-520, IO-550, IOF-550, TSIO-550, TSIOF-550
.56-18	Nut, Starter Jaw, Crankshaft	575-625	47.9-52.1	O-470-Numeral
.56-18	Nut, Generator Pulley Drive	450-500	37.5-41.7	IO-346, ALL 470, IO-520, TSIO-520, IO-550, IOF-550, TSIO-550, TSIOF-550 & TSIOL-550
.56-24	Screw, Shoulder, Air Conditioning Idler Sheave	800-850	66.6-70.8	TSIO-520-BE, TSIO-550, TSIOF-550
.62-32	Nut, Alternator Hub Assembly	300-450	25.0-37.5	IO-346, IO-520(AR), TSIO-520 (AR), GTSIO-520 (AR), IO-550, IOF-550, TSIO-550, TSIOF-550 & TSIOL-550



Torque Specifications

Table B-2. Component Specific Torque Specifications

Size	Fastener	Torque Value		Models Affected (Non-standard, see General Torque Specification)
		In.-Lbs.	Ft.-Lbs.	
.66-20	Nut, Alternator or Generator Pulley	450-500	37.5-41.7	O-470, IO-470, IO-520 (AR), TSIO-520 (AR), IO-550, IOF-550, TSIO-550, TSIOF-550 & TSIOL-550
.75-16	Nut, Starter Shaft Gear, Viscous Damper	---	180-220	GTSIO-520
.88-18	Adapter, Tachometer Reduction Gear	120-180	10.0-15.0	IO-240, IOF-240 & All 360

1. Heat crankshaft gear to 300° F; install gear on crankshaft immediately for shrink fit. Ensure the gear seats tightly against the end of the crankshaft by tapping lightly with a brass hammer.
2. Torque to low limit. If cotter pin will not align with holes, increase torque gradually, up to high limit only. If cotter pin holes will not align within torque range, replace the nut and repeat. In no case shall nuts be tightened below the minimum or above the maximum torque limit. Refer to the most current revision of Continental Motors Service Document SIL93-15 for special cotter pin installation instructions in 360 series engine connecting rods.
3. A) P/N 530184 connecting rod (identified by forging number 530186), P/N A35159 (identified by forging 5561) and P/N A35160 (also identified by forging number 5561) must be assembled with P/N 530213 bolt, P/N 24804 or 626140 nut and P/N 639292 cotter pin.
B) Assemble P/N A36121 connecting rods utilizing the P/N 632041 forging with the part numbers indicated in current technical data. Assemble P/N A36121 connecting rod assemblies utilizing the P/N 40742 forging with P/N 35972 connecting rod bolt, P/N 24804 nut and P/N MS24665-132 cotter pin.
4. Bolt P/N superseded by 655960. Do not mix with obsolete parts.
5. Bolt P/N superseded by 655959. Do not mix with obsolete parts.
6. Snug nut finger tight to set seal between nut and male connector, then tighten additional 3/4 to 1 turn.
7. Install fitting hand-tight. Wrench tighten the cross fitting to the appropriate clocking of fitting within 1-3 turns from the finger tight position. Minimum torque of 185 in/lbs must be achieved upon clocking position of fitting. The fitting is not to be loosened in order to achieve proper alignment (clocking).
8. Apply Loctite Pipe Sealant 592.
9. Lubricate spark plug threads with spark plug manufacturer's recommended lubricant.
10. Install baffle screw until seated against flat washer; then, tighten an additional 2-6 turns. Baffle to be snug but not distorted. Verify minimum one (1) thread protrudes past nut plate on lower cylinder baffle.
11. Do not realign hex cap screw to mate with tab washer.
12. Must be reworked to through bolt rocker shaft configuration according to most current revision of CM Service Document M92-6.
13. Strike outer periphery of coupling band lightly to distribute load. Tighten to 50-60 in/lb. for P/N 641284 clamp and 60-70 in/lb. for P/N 653832 clamp.
14. Align and adjust compressor belt tension according to most current revision of CM Service Document M89-6.



Table B-3. Specific Torque Specifications (Non-Lubricated Hardware)

Size	Fastener	Torque Value		Models Affected
		In.-lbs.	Ft.-lbs.	
---	Clamp, Hose (Worm Gear)	25-35	2.0-2.9	All Models (AR)
#8-32	Screw, Throttle Lever	17.5-22.5	1.5-1.9	All Models (AR)
#10-32	Nut, Magneto Ground Terminal	15-17	1.25-1.41	CM S-20/200, S-1200 Magnetos
#10-32	Nut, Magneto Ground Terminal	13-15	1.08-1.25	Slick Magnetos
#10-32	Screw, Ignition Harness Cable Outlet Plate	12-15	1.0-1.25	CM S-20/200 Magnetos
Various	Nut, Ignition Harness Cable Outlet Plate	18-22	1.5-1.8	CM S-1200 Magnetos
Various	Screw, Ignition Harness Cable Outlet Plate	18-28	1.5-2.33	Slick Magnetos
.125-27	Fuel Injector Nozzle to Cylinder ¹	55-65	4.6-5.4	All Fuel Injection Models
.31-24	Nut, Cable Attach	55-60	4.6-5.0	All w/Energizer Starter
.31-32	B-Nut, Fuel Injection Line to Fuel Injector Nozzle	40-45	3.3-3.8	All Models (AR)
.375-24	B-Nut, Fuel Injection Line to Fuel Manifold Valve	55-60	4.6-5.0	All Non-FADEC Fuel Injected
.56-24	Sensor, Magneto (Tachometer)	35-40	2.9-3.3	All Models (AR)
.625-24	B-Nut, Ignition Lead to Spark Plug	90-95	7.5-7.91	All Non-FADEC
.68-24	Sensor, Magneto (Tachometer)	35-40	2.9-3.3	All Models (AR)
.75-20	B-Nut, Ignition Lead to Spark Plug	110-120	9.2-10.0	All Non-FADEC
1.12-18	Oil Pressure Relief Valve Housing	240-260	20.0-21.7	All Models (AR)

1. Apply Continental Motors P/N 646943 Anti-Seize Compound

Table B-4. FADEC Components (Non-Lubricated Hardware)

Size	Fastener	Torque Value		Models Affected
		In.-lbs.	Ft.-lbs.	
#4	Screw, ECU 50-Pin Connector	10-15	0.83-1.25	All FADEC
#4	Screw, Speed Sensor 25-Pin Connector	10-15	0.83-1.25	All FADEC
#10	Bolt, Ground Strap	25-35	2.02.9	All FADEC
.125-27	Adapter Fitting, Manifold Air Temperature	60-80	5.0-6.6	All FADEC
.25-18 NPT	Sensor, Fuel Pressure	130-150	10.83-12.5	All FADEC
.25-18 NPT	Sensor, Manifold Pressure	130-150	10.83-12.5	All FADEC
.25-24	Bolt, ECU Mount	60-70	5.0-5.83	All FADEC
.25-.62	Clamp, Exhaust Gas Temperature Sensor	30-35	2.5-2.9	All FADEC
.31-32	Nut, Fuel Injection Solenoid Retaining	24-28	2.0-2.3	All FADEC
.375-24	Bayonet Adapter, Cylinder Head Temp. Sensor	55-65	4.58-5.41	All FADEC
.375-24	Fuel Injection Line to Fuel Distribution Block	55-60	4.6-5.0	All FADEC
.437-24	Compression Fitting, Manifold Air Temp. Ferrule	145-155	12-12.9	All FADEC
.75-20	B-Nut, Ignition Harness to Spark Tower	110-120	9.1-10.0	All FADEC
.75-20	Jam Nut, ECU Spark Tower	110-120	9.1-10.0	All FADEC



Table B-5. General Torque Specifications

Bolts, Nuts, Screws		
Size	Torque	
	In. lbs.	Ft. lbs.
#2-56	1.4-2.6	N/A
#4-40	2.9-5.5	N/A
#6-32	5.3-10.1	N/A
#8-32	17.5-22.5	1.5-1.9
#10-32	36-50	3.0-4.2
#10-24	21-25	1.7-2.0
.250-20	75-85	6.3-7.1
.250-28	90-100	7.5-8.3
.3125-18	155-175	12.9-14.6
.3125-24	180-220	15.0-18.3
.375-16	220-260	18.3-21.7
.375-24	275-325	22.9-27.1
.44-20	400-450	33.3-37.5
.50-20	550-600	45.8-50.0
Driving Studs		
.250-20	50-70	4.2-5.8
.3125-18	100-150	8.3-12.5
.375-16	200-275	16.7-22.9
.44-14	300-425	25.0-35.4
Pipe Plugs		
.062-27	30-40	2.5-3.3
.125-27	60-80	5.0-6.7
.250-18	130-150	10.8-12.5
.375-18	185-215	15.4-18.0
.500-14	255-285	21.3-23.8
.750-14	310-350	25.8-29.2

Table B-6. Hydraulic Line Torque Specifications

Hose Size	Hose End Fitting Material	Torque (In.-lbs.)	Models Affected
.44-20	Nut-Self-Locking #4 hose	115-165	TSIO-520-L, LB, WB
.56-18	Nut-Self-Locking #6 hose	185-335	TSIO-520-L, LB, WB
.75-16	Nut-Self-Locking #8 hose	360-570	TSIO-520-L, LB, WB



NOTE: Fitting torques in Table B-7 shall not be used for tapered fittings. For tapered (NPT/NPTF) fittings that must be oriented to a specific angle (clocked) for mating with another fitting or hose, screw the fitting into the port finger-tight. Wrench tighten additional 2-3 turns until the fitting is oriented at the desired angle. Do not loosen the fitting to achieve proper alignment.

Table B-7. Straight Thread Fitting Torque Specifications

Size	Fitting Size	Torque (In.-lbs.)
.31-24	Brass / Aluminum	15-30
.31-24	Steel	15-50
.38-24	Brass / Aluminum	40-65
.38-24	Steel	50-90
.44-20	Brass / Aluminum	60-80
.44-20	Steel	70-120
.44-24	Steel	60-80
.56-18	Brass / Aluminum	75-125
.56-18	Steel	90-150
.75-16	Brass / Aluminum	150-250
.75-16	Steel	135-250
.88-14	Brass / Aluminum	200-350
.88-14	Steel	300-400

Table B-8. Hose Fitting (“B” Nut) Torque Specifications

Hose Size	Hose End Fitting Material	Torque (In.-lbs.)
-2 (.31-24)	Brass/Aluminum Fitting	50-80
-2 (.31-24)	Steel Fitting	75-120
-3 (.38-24)	Brass/Aluminum Fitting	70-105
-3 (.38-24)	Steel Fitting	95-140
-4 (.4375-20)	Brass/Aluminum Fitting	100-140
-4 (.4375-20)	Steel Fitting	135-190
-5 (.500-20)	Brass/Aluminum Fitting	130-180
-5 (.500-20)	Steel Fitting	170-240
-6 (.5625-18)	Brass/Aluminum Fitting	150-195
-6 (.5625-18)	Steel Fitting	215-280
-8 (.750-16)	Brass/Aluminum Fitting	270-350
-8 (.750-16)	Steel Fitting	470-550
-10 (.875-14)	Brass/Aluminum Fitting	360-430
-10 (.875-14)	Steel Fitting	620-745
-12 (1.063-12)	Brass/Aluminum Fitting	460-550
-12 (1.063-12)	Steel Fitting	855-1055



Torque Specifications

Intentionally Left Blank



Appendix C. Maintenance Standards

C-1. Handling Parts

When removing, replacing, or reinstalling parts, heed the following precautions, warnings, and tips:

WARNING

Turn the Ignition Switch OFF and disconnect engine electrical power before commencing maintenance or inspections. Confirm continuity between the magneto capacitor and aircraft ground to prevent accidental engine start during maintenance. Do not stand or place equipment within the arc of the propeller.

- If the engine is installed, disconnect engine electrical (battery) power and verify the Ignition Switch is turned OFF. Confirm continuity between the magneto capacitor and aircraft ground before commencing engine maintenance.
- Inspect replacement parts for deterioration or wear. Do not install parts that appear worn, deteriorated, or beyond published (service or overhaul) limits.
- Prevent safety wire, nuts, washers, dirt, etc. from entering the engine.
- If any foreign object accidentally falls into the engine, stop working on the engine immediately and retrieve the dropped object(s).
- Tag unserviceable parts or units for investigation and possible repair.
- To ensure proper reinstallation of usable parts, tag or mark all parts and hardware as they are removed or disassembled.
- Use protective caps, plugs, and covers to ensure openings are unexposed. Install dust caps **over** the tube ends of open lines and **NOT IN** the tube ends. Be sure to remove the dust caps and covers after the maintenance or repair work is complete.
- Cover stored engine sub-assemblies.
- Inspect new parts for transit damage. **Do not install damaged or non-conforming parts.** Re-seal or rewrap the new part until the part is ready to be cleaned, prepared, and installed.
- Check the shelf life of new parts to be installed. Do not install parts with an expired shelf life.
- Thoroughly clean parts according to the instructions in Chapter 12.
- Use only a plastic or rawhide mallet made to tap engine parts during assembly; never use a hammer.
- Always install new gaskets, o-rings, rubber components, seals, packing, cotter pins, tab washers, safety wire, and lock washers when servicing components.
- Use only new, shake proof or split lock washers, tab washers, elastic stop nuts, cotter pins, and corrosion-resistant safety wire.
- Do not replate cadmium-plated fasteners or washers. If the cadmium plating has been removed, discard the item and replace it with a new part.
- Do not reinstall any worn, deformed, or single use fasteners.



- Torque hardware to Appendix B torque specifications.

WARNING

Do not apply any form of sealant to the crankcase cylinder deck, chamfer, cylinder mounting flange, cylinder base O-ring, or cylinder fastener threads. The use of RTV, silicone, Gasket Maker or any other sealant on the areas listed above during engine assembly will cause a loss of cylinder deck stud or through-bolt torque. Subsequent loss of cylinder attachment load, loss of main bearing crush and/or fretting of the crankcase parting surfaces will occur. The result will be cylinder separation, main bearing movement, oil starvation and catastrophic engine failure. USE ONLY CLEAN 50 WEIGHT AVIATION ENGINE OIL ON SURFACES LISTED.

- Before installing nuts and bolts, verify the fastening hardware is lubricated according to instructions in Chapter 3 and Appendix B instructions. Inspect all fasteners for proper plating and thread form. Failure to verify a fastener's serviceability or to correctly lubricate the fastener as instructed prior to installation will result in the fastener not being properly pre-loaded. Subsequent fastener failure may occur.



C-2. Replacement Parts

C-2.1. Background

An increasing amount of replacement parts (including standard parts), materials, appliances, and instruments are represented as being of aircraft quality when actually the quality and origin of these units is unknown. Users of such units are usually not aware of the potential hazards involved with replacement parts that are not eligible for use on certified aircraft. Frequently, such units are deceptively advertised or presented as “unused,” “like new,” or “remanufactured,” implying the quality of such units is equal to an original or appropriately repaired or overhauled unit.

The performance rules for replacement of parts and materials used in the maintenance and alteration of U.S.-certified aircraft are specified in Title 14 Code of Federal Regulations (CFR) §§ 21.9.

C-2.2. Acceptable Replacement Parts

Continental Motors provides Instructions for Continued Airworthiness (ICAs) based on the design, testing, and certification of engines and parts for which Continental Motors is the holder of the Type Certificate (TC) or Parts Manufacture Approval (PMA) issued by the Federal Aviation Administration (FAA). These instructions, which include maintenance, repair limits, overhaul, and installation are applicable only to engines and parts supplied by Continental Motors. Continental Motors does not provide instructions relating to the installation or use of parts not manufactured or supplied by Continental Motors. Instructions provided by other engine parts manufacturers or resellers should be used for their parts. Continental Motors has not participated in design, test, or certification in regards to aftermarket parts manufacturers and has no experience with respect to such parts.

FAA regulations require only FAA-approved parts be used on a type certified product. FAA-approved parts may be identified in accordance with the information given below. Continental Motors does not play any role in the FAA approval of such parts; does not have any responsibility for the design, certification, service life, repair, overhaul, or quality of such parts; and has made no determination regarding the effect, if any, that using such parts may have on Continental Motors supplied engines or parts.

C-2.2.1. Know Your Supplier

Some reproduced parts and components, particularly instruments, have been manufactured by entities other than the original equipment manufacturer and are available for purchase and installation on U.S.-certified aircraft. Often, an original part is used as a sample to produce duplicates. The reproduced parts *appear* to be as good as the original part. However, there are many unknown factors to be considered that may not be readily apparent to the purchaser, such as heat-treating, plating, inspections, tests, and calibrations. All too often, the faulty part is not discovered until a malfunction or an accident occurs.

Therefore, in accordance with federal aviation regulations, certification of materials, parts, and appliances for aircraft return to service is the responsibility of the person or agency who signs the approval. The owner/operator is responsible for the continued airworthiness



Maintenance Standards

of the aircraft. To ensure continued safety in aircraft operation, it is essential that great care be used when inspecting, testing, and determining the acceptability of all parts and materials. Particular caution should be exercised when the identity of materials, parts, and appliances cannot be established or when their origin is in doubt.

C-2.3. 100% Parts Replacement Requirements

“100% Replacement” parts are items that require a “new” replacement if removed during any maintenance or preventive maintenance on the engine or its components. You must always replace removed gaskets, seals, packings, hoses, “O” rings, cotter pins, retaining rings (snap rings), safety wires, self locking fasteners (including exhaust and connecting rod nuts) and lock washers with “new” serviceable parts.

NOTE: Service documents published or revised subsequent to the issuance of this publication may mandate the replacement of components and parts not included in these instructions. At engine overhaul, the technician must review all service bulletins to ensure compliance with the manufacturer’s requirements for continued airworthiness.

Do not re-use worn, damaged or deformed fasteners. Do not replate cadmium plated fasteners or washers. If the cadmium plating has been removed, discard the item and replace it with a new part.

Engine mounted accessories must be maintained in accordance with the manufacturer’s instructions. Additionally, accessories must be overhauled during engine overhaul, or more frequently, in accordance with the manufacturer’s instructions.

At engine overhaul the starter, starter adapter, alternator, magnetos, and engine fuel system must be replaced with New, Factory Rebuilt, or FAA approved overhauled units. On turbocharged engines, the turbocharger, wastegate, all controllers, bypass valve and exhaust system must be replaced with new, factory rebuilt or FAA approved overhauled units. All engine baffles must be repaired or replaced and all flexible baffle seals replaced.

Items such as spark plugs, alternator drive belts and air-conditioning drive belts are replaced on condition.



C-2.4. Mandatory Overhaul Replacement Parts

In addition to the items listed in Section C-2.3, mandatory replacement parts must be discarded and replaced with new parts during engine overhaul.

Table C-1. Mandatory Overhaul Replacement Parts

REPLACEMENT ITEMS	SPECIAL CONDITIONS	100% REPLACEMENT	MANDATORY REPLACEMENT AT ENGINE OVERHAUL
Accessories, Engine Mounted ¹	Replace On Condition		X
Air-conditioning Drive Belts	Replace On Condition		X
Alternators <ul style="list-style-type: none"> • Drive Belts • Rubber Drive Bushings 	Replace On Condition		X X
Baffles (see Engine Baffles)	Repairable		X
Bearings: connecting rod, crankshaft main and thrust, needle, ball, and roller			X
Bushings: used in bearing applications (subject to wear) - reference disassembly/assembly instructions			X
Camshaft Gears: <ul style="list-style-type: none"> • Replace P/Ns 535934, or 535660, or 656037 (O470J, K, L, R, S, U; IO346A; IO470J, K) with 656913, or subsequent part number, at overhaul. • Replace P/Ns 537432 or 656038 (O470G, GCI, M; IO470C, D, E, F, H, L, M, N, S; TSIO470B, C, D; GTSIO520C, D, H, K, L, M, N, R) with 656914, or subsequent part number, at overhaul. • Replace P/Ns 631845, or 655516, or 656031 (IO470U, V; IO520A, B, BA, BB, C, CB, D, E, F, J, K, L, M, MB, N, NB, P, R; LIO520P; L/TSIO520ALL; IO550A, B, C, D, E, F, G, L, N, P, R; IOF550ALL; TSIO550A, B, C, E; TSIO550A, B, C), or 655430 (IO550A, B, C, D, E, F, G, L, N) with P/N 656818 or subsequent part number) 	Design Change	X	
Camshaft Gear Bolts			X
Cold Start Primer Diverter Valves			X
Connecting Rods (must be inspected for serviceable condition during Overhaul) <ul style="list-style-type: none"> • Connecting Rods (P/N 626119, 646320, and 646321 must be replaced with current part number)² See Section 10-9.1 for engine applicability • Connecting Rods (with beam widths less than 0.625 inches must be replaced with current part number)² • Connecting Rod Bolts • Connecting Rod Nuts 	Inspection Required Design Change Design Change	X X	X X
Cotter Pins		X	
Counterweight <ul style="list-style-type: none"> • Counterweights (P/N 631810 must be replaced with P/N 652833)³ • Counterweight Pins • Retainer Plates • Retaining (Snap) Rings 	Design Change	X	X X X X
Crankcase Through Bolts			X
Crankshaft Gears <ul style="list-style-type: none"> • Crankshaft Gear (P/Ns 536421 or 653631 must be replaced with P/N 657175, or subsequent)³ • Crankshaft Cluster Gear (P/Ns 641906 or 656272 must be replaced with P/N 656072, or subsequent)⁴ • Crankshaft Gear, large (P/N 656991 Rev B must be replaced with P/N 656991 Rev.C, or subsequent)⁵ • Crankshaft Gear Bolts 	Design Change Design Change Design Change	X X X	X



Maintenance Standards

Table C-1. Mandatory Overhaul Replacement Parts

REPLACEMENT ITEMS	SPECIAL CONDITIONS	100% REPLACEMENT	MANDATORY REPLACEMENT AT ENGINE OVERHAUL
Crankshaft Gears, continued			X
• Crankshaft Alternator Face Gear Bolts			X
• Crankshaft Alternator Face Gear Lock Plates			X
Cylinder Deck Stud Nuts and Through Bolt Nuts			X
Engine Baffles (see Baffles)	Repairable		X
Engine Mounted Accessories ¹	Replace On Condition		X
Exhaust Nuts			X
Exhaust Valves and Rotocoils			X
FADEC			X
• Electronic Control Units			X
• Engine Low Voltage Harness (including EGT and CHT sensors)			X
• Fuel Filter			X
• Fuel Injectors			X
• Fuel Pressure Sensors			X
• Manifold Air Pressure Sensors			X
• Oil Pressure Sensor, if equipped			X
• Oil Temperature Sensor, if equipped			X
• Signal Conditioner, if equipped			X
• Speed Sensor			X
• Turbine Inlet Temperature Sensor(s), if equipped			X
Filters, replaceable (air, oil, fuel, magneto), if equipped	Replace On Condition		X
Flexible Baffle Seal		X	
Fuel Systems			X
Fuel Pump Drive Coupling (P/N 631263 must be replaced with P/N 653359, or subsequent part number) ⁶ on all IO520B, BA, BB, C, CB, M, MB, N, NB; TSIO520B, BB, BE, D, DB, E, EB, J, JB, K, KB, L, LB, N, NB, UB, VB, WB; IO550A, B, C, G, N, P, R; TSIO550A, B, C, E; TSIOL550A, B, C	Design Change	X	
Gaskets		X	
Hoses		X	
Hydraulic Lifters (tappets)			X
Ignition System Harness			X
Intake Valves	Replace On Condition		
Lock Washers		X	
Magnetos			X
• Magneto Rubber Drive Bushings			X
“O” Rings		X	
Oil Pump Gears (O-300, IO-360, TSIO-360 and LTSIO-360 Series) ⁷	Design Change	X	
Oil Suction Screens (360 series P/Ns 649470, 649471, 652669, 652670 must be replaced with current part number) ⁷	Design Change	X	
Oil Suction Screens (C-125, C-145 and O-300 series P/N 633272 must be replaced with current part number) ⁷	Design Change	X	
Packings		X	
Pistons			X
• Pins			X
• Rings			X



Table C-1. Mandatory Overhaul Replacement Parts

REPLACEMENT ITEMS	SPECIAL CONDITIONS	100% REPLACEMENT	MANDATORY REPLACEMENT AT ENGINE OVERHAUL
Intake Valve Rotocoils (except all E-series, O-470, IO-470, IO-520 / 550, TSIO-520 / 550 TSIOL-550 and GTSIO-520 engines) ⁸	Design Change	X	
Rocker Shafts			X
Rocker Shaft Thrust Washers			X
Rotocoils, Exhaust			X
Safety Wire		X	
Seals		X	
Self Locking Nuts		X	
Snap Rings		X	
Solid Valve Spring Retainers			X
Spark Plugs	Replace On Condition		X
Starter ⁴			X
• Starter Adapter Assemblies (replace all GTSIO520 with EQ6642) ⁹	Design Change	X	
Turbochargers			X
• All Controllers			X
• Bypass Valve			X
• Exhaust Clamps			X
• Exhaust System			X
• Oil Supply Valves			X
• Return Check Valves			X
• Snap Rings			X
• Wastegate			X
Valve Keepers (intake/exhaust)			X
Valve Springs (inner/outer)			X
Woodruff Keys		X	

1. Engine mounted accessories must be maintained and overhauled at engine overhaul, or more frequently, in accordance with the manufacturer's instructions.
2. Reference Critical Service Bulletin CSB96-13 (or latest revision)
3. Reference Section 10-9.1 (was **SB00-3**)
4. Reference Service Bulletin SB14-2 (or latest revision)
5. Reference Service Bulletin SB13-6 (or latest revision)
6. Reference Mandatory Service Bulletin MSB 95-6 (or latest revision)
7. Reference Service Bulletin SB96-4 (or latest revision)
8. Replace intake valve rotocoils with solid valve spring retainers on all E-series O-470, IO-470, IO-520/550, IOF550, TSIO-520/550, TSIOL-550, TSIOF550, and GTSIO-520 engines.
9. Reference Service Bulletin MSB94-4 (or latest revision). Overhaul is prohibited on starter adapters with scavenge pump, P/N 658440. On GTSIO-520; all EQ6642 starter adapter assemblies (both new and factory rebuilt) include new torsional damper, starter adapter shaftgear, and crankshaft gear.

C-2.5. Authorized Oversize/Undersize Parts

Replacement authorized oversize (AO) or authorized undersize (AU) parts must be used with the proper AO and AU mating parts. Example: use 0.015 oversize piston and piston rings with 0.015 oversize cylinder assembly.



■ C-2.6. Engine Data Plate Replacement

The engine data plate is intended to remain with the engine throughout its service life. On occasion, an engine data plate may be damaged, stolen, or lost.

Replacement engine data plates are available from the manufacturer, if the following conditions are met:

1. Request must be in writing
2. Request must be coordinated through the nearest FAA office (or equivalent airworthiness authority), with written endorsement as specified in Title 14 CFR 45.13, paragraph (b) and (d).
3. If the engine data plate has been lost or stolen, or if a removed data plate is being retained by the airworthiness authority, the requestor must obtain written certification from the airworthiness authority on official letterhead verifying the engine model number and serial number of the engine from which it was removed.
4. Unless item 3 above applies, the original data plate must accompany the written request for the replacement data plate.
5. Enclose a check or money order payable to Continental Motors, in US funds, in the amount of \$100.
6. Submit request to:
Continental Motors
P.O. Box 90
Mobile, AL 36601
ATTN: Customer Service Department

■ C-2.6.1. Removal and Installation of Engine Data Plate

Please refer to 14 CFR part 45.13 and latest revision of AC45-3 prior to removing or installing an engine data plate.

■ C-2.6.1.1. Data Plate Removal

The engine data plate is secured to the crankcase with single use, rivet-like fasteners, called drive screws.

CAUTION: Do not mar or damage the crankcase during the replacement procedure.

1. Carefully insert a wide blade gasket scraper between the data plate and the crankcase adjacent to each drive rivet. As the data plate is lifted, the drive screw should release from the crankcase.
2. Repeat step 1 for each of the five remaining drive screw rivets. Discard the drive screws.



C-2.6.1.2. Data Plate Installation

1. Check the alignment of the new data plate with the existing holes in the crankcase. If the crankcase is new, follow the instructions for if the existing drive screw holes do not align.
2. If the existing drive screw holes do not align with the new data plate:
 - a. Patch the existing holes with 3M Part Number 1838, “Scotch Weld” structural adhesive, or Loctite Part Number 44581, “Fast Cure” epoxy.
 - b. Install a drill stop on a #51 (0.067 inch dia.) drill bit at a depth of 0.19 inch. Install the drill bit in a hand drill.
 - c. Use the data plate as a template to mark the center of the new holes.
 - d. Drill the six drive screw holes to a depth of 0.19 inch.
 - e. Clean the aluminum shavings from the crankcase.
 - f. Fasten the data plate with to the right (1-3 (4 cylinder) of 1-3-5 (6 cylinder) side of the crankcase with six each new Part Number 24764 drive screws.
3. If the existing drive screw holes align with the new data plate:
 - a. Install a drill stop on a #44 (0.086 inch dia.) drill bit at a depth of 0.19 inch. Install the drill bit in a hand drill.
 - b. Drill the existing six screw holes slightly oversize with the #44 drill bit to a depth of 0.19 inch.
 - c. Clean the aluminum shavings from the crankcase.
 - d. Fasten the data plate with to the right (1-3 (4 cylinder) of 1-3-5 (6 cylinder) side of the crankcase with six each new Part Number 21007 drive screws.
4. For Rolls Royce Engines manufactured under license from Continental Motors:
 - a. The new data plate does not alter the original certification basis of the engine.
 - b. The engine model will retain the original RR- prefix in the engine designation.
 - c. The engine will retain the data from the original Rolls Royce serial number and Type Certificate number issued by the CAA.

C-2.7. Special Instructions

It is recommended that a new or factory rebuilt replacement EQ6642 kit be installed during any prop strike/sudden engine stoppage inspection for all GTSIO-520 engine models.

C-3. Safety Wiring Hardware

Safety wiring secures two or more parts together so any tendency of the parts to loosen will be counteracted by increasing the tension on the safety wire attached to the other part(s). Remove safety wire to loosen the fasteners. Never reuse safety wire; always use new safety wire to secure hardware. Safety wire on these engines must conform to MS20995 Condition A.

1. Verify the hardware (bolts or nuts) to be safety wired has been correctly torqued to Appendix B specifications.

CAUTION: Do not apply torque above or below specified limits to align holes.

2. Insert half of the required length of new safety wire through the first piece of hardware and do the following:
 - a. For *right-hand* threaded hardware, install the safety wire so the strand will pull and lock *clockwise*.
 - b. For *left-hand* threaded hardware, install the safety wire so the strand will pull and lock *counter-clockwise*

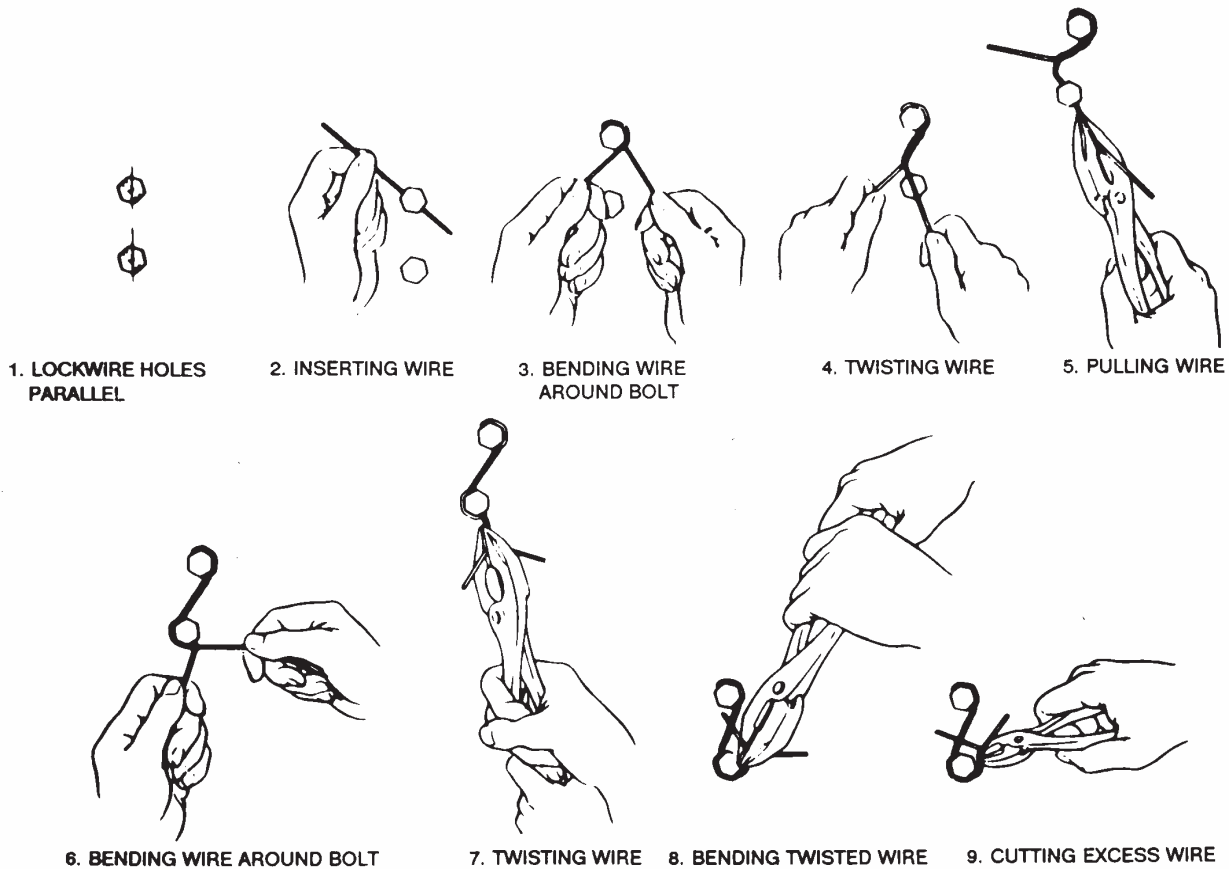

Figure C-1. Right-hand-thread safety wire installation
(Reverse application for left hand threads)



3. As shown in Figure C-1, bend the safety wire to tightly loop around the head of the hardware so force is exerted in the tightening direction. Ensure there is no slack in the loop and the loop is under the protruding strand that will wrap around the opposing piece of hardware to ensure the loop is held in place on the first device. Pull the protruding strand of safety wire with pliers until it is taut (but not overstressed).
4. While keeping the protruding strand of safety wire taut, twist the strands (based on the wire gauge specified below) until the twisted part is just short of a hole in the next unit. The twisted portion should be within one-eighth (1/8) inch from the hole in either unit:
 - a. Twist 0.032" diameter safety wire at a rate of 7 to 10 twists per inch.
 - b. Twist smaller diameter safety wire at a rate of 9 to 12 twists per inch.
5. Pull the braided safety wire strand with pliers until it is taut (but not overstressed).
6. Insert the uppermost strand through the hole in the second piece of hardware.
7. Bend and wrap the twisted wire braid around the second piece of hardware, pulling the wire taut as described in the previous steps, which will counter-lock the hardware joined by the safety wire. Repeat the previous steps for any subsequent hardware to be safety wired by this strand. Refer to Figure C-2 for various safety wire patterns. All safety wire must fit snugly.
8. After safety wiring the last piece of hardware, continue twisting the safety wire to form a pigtail, providing sufficient twists (four minimum) to ensure the pigtail will not unravel.

CAUTION: Do not allow the safety wire pigtail to extend above the bolt head.
9. Trim excess safety wire and bend the pigtail toward the hardware and against the bolt head flats.

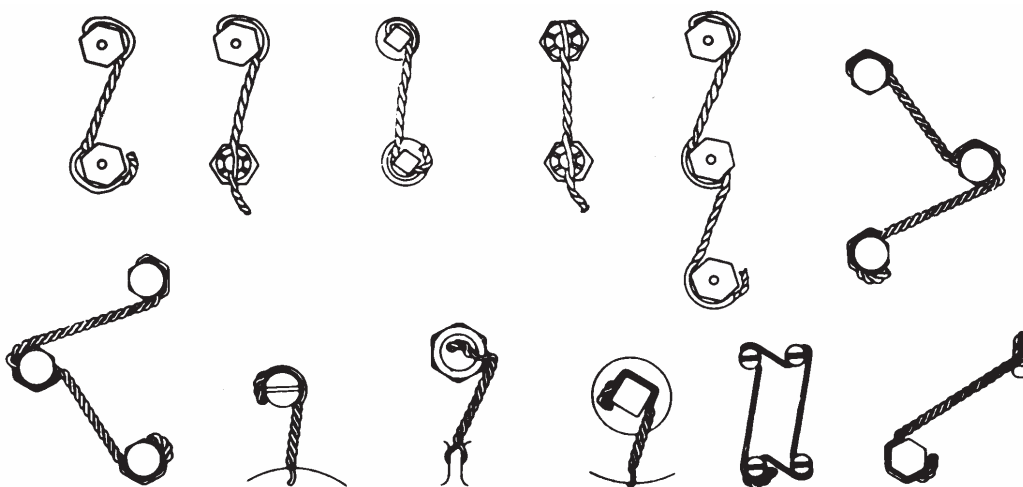

Figure C-2. Safety wire Patterns for Right-Hand Threads
(Reverse the wire orientation for left-hand threads)



C-4. Tab Washer Installation

Tab washers are used in various locations on Continental Motors engines. Do not re-use tab washers. Always install new tab washers.

1. Insert the locator tab (bent part of the tab washer) in the pre-drilled hole.
2. Lubricate and torque hardware to Appendix B specifications.

CAUTION: Repositioning the fastener after torque application to align the tab washer with the flat portion of the nut or bolt is prohibited.

3. Using a soft drift, bend the lock tab on the other side of the tab washer firmly against the bolt (or nut) flats as shown in Figure C-3. Ensure the lock tabs are bent flat up against the hardware without protrusion as shown in top and side views to properly lock the hardware and prevent the lock tabs from breaking off.

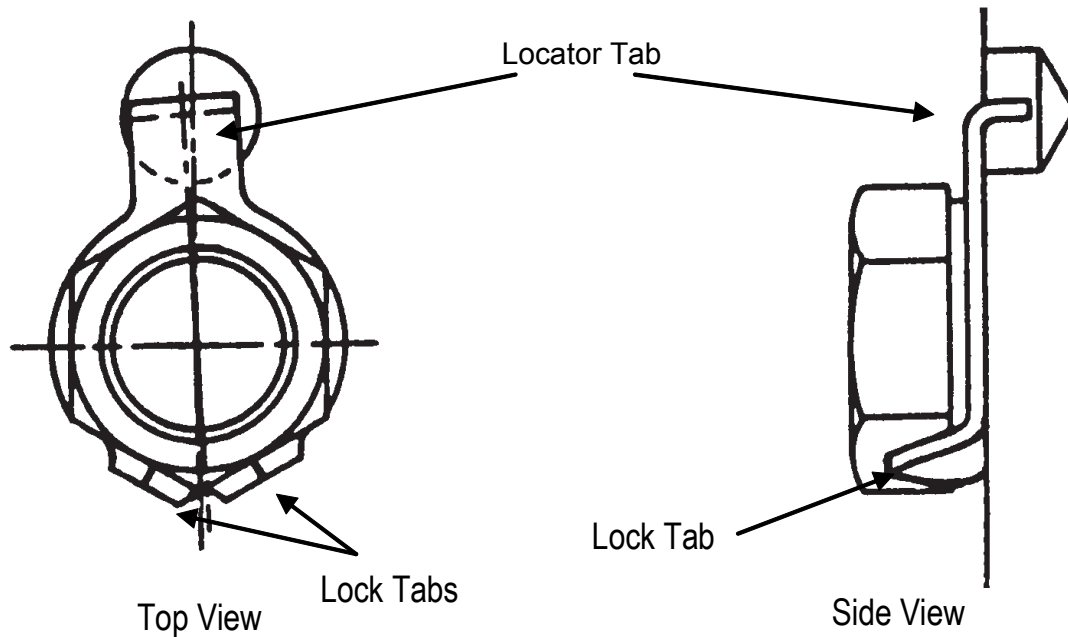

Figure C-3. Tab Washer Installation



C-5. Heli-Coil® Insert Replacement

Helical coil inserts are made of wire with a diamond-shaped cross section forming both a male and female thread. Heli-coil® inserts are factory-installed in various tapped holes of some engine components. Stainless steel heli-coil inserts of special design are installed in all spark plug holes.

Tools, inserts, and information are available through Heli-Coil, Stanley® Engineered Fastening (formerly Emhart Teknologies). The latest revision of the manufacturer's bulletins 959A, 995, 943, T4000, and 1000 list manual and power-driven installing tools, tang break-off tools, special taps, plug gauges, and tap/drill information.

Heli-coil inserts are available in both National Course and National Fine series in lengths equal to 1, 1½, and 2 times nominal diameter and in pipe thread sizes. They are made of carbon steel, phosphor bronze, or stainless steel, as specified by part number. They are supplied with or without a notch above the driving tang. The notch is provided to facilitate breaking off the tang in open holes.

When compressed into a special tapped hole at the widest part of the wire between male and female threads, the diameter of the insert is equal to the nominal screw size. The special finishing taps size the threaded hole to allow the pitch diameter of the female thread of the installed insert to conform to Class 3 fit with standard bolt threads or Class 4 (tight) fit with standard-size studs. The difference in fit is due to a difference in pitch diameters of bolts and studs.

Only one set of heli-coil special taps is required for installing these inserts in both bolt holes and stud holes. Tap drilling depths and tapping depth for heli-coil inserts to be installed in blind holes must conform to the recommendations relative to inserts of length equal to 2 times nominal diameter, as tabulated in the latest revision of the manufacturer's bulletin numbers 1000 and T4000.

Run heli-coil tap drills and special taps perpendicular to the machined surface to follow the alignment of the existing hole.

For drilling and tapping aluminum alloy castings, use a commercial-grade cutting lubrication oil to prevent overheating of the metal and tearing of the thread.

Heli-coils are prohibited in certain areas; verify that a heli-coil repair for a certain area is approved prior to installing the heli-coil.

Replace heli-coils in approved areas when they are damaged in accordance with the manufacturer's instructions.



C-5.1. Heli-Coil Removal

1. Use the proper size extracting tool (Figure C-4) for the nominal thread size.
2. Tap the extracting tool into the heli-coil insert until the sharp edges of the tool dig firmly into the heli-coil insert.
3. Turn the tool to the left and back out the heli-coil until it is free.

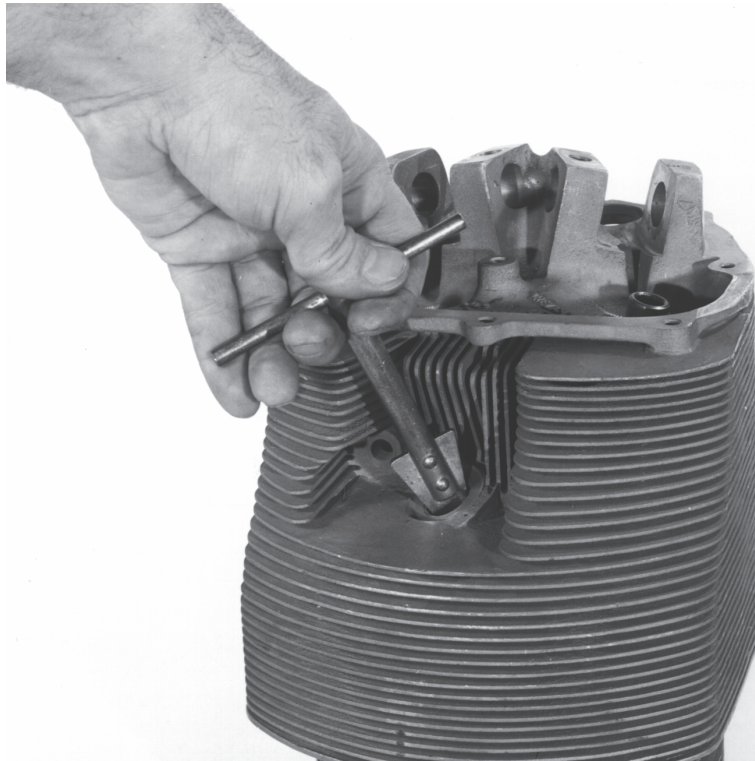

Figure C-4. Heli-Coil Extraction Tool

C-5.2. Heli-Coil Insertion

1. Blow all debris and liquid out of the tapped hole.
2. Use a proper size installation tool and slide the new heli-coil insert over the slotted end of the driving mandrel of the tool.
3. Engage the driving tang (bent end) of the heli-coil in the mandrel slot.
4. Wind the insert slowly into the tapped hole (as shown in Figure C-5).
5. The outer end of the insert must lie within the first full thread of the hole.
6. Break off the driving tang of a notched heli-coil by bending it back and forth across the hole with long, needle nose pliers or with a special tang break-off tool.
7. Once the heli-coil insert is installed, the remaining wall thickness (edge distance) to the heli-coil must not be less than one half the heli-coil diameter or 0.08 inches, whichever is greater.

WARNING

On the crankcase, the 2 and 4 o'clock cylinder deck stud positions must not be repaired by heli-coil insert installation.

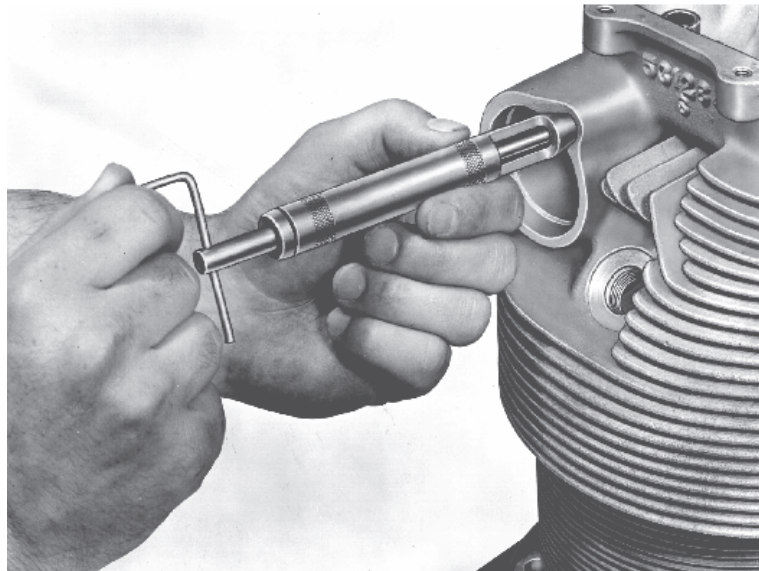

Figure C-5. Installing a Helical Coil Insert



C-6. Stud Replacement

Studs that are damaged or broken must be replaced. Rosan[®] ring-locked studs, which were previously installed in the cylinder exhaust ports have been replaced with standard stainless steel studs. These Rosan studs are either “size-on-size” or “step type.” When replacing studs, consult the illustrated parts catalog for the most current cylinder configuration.

NOTE: Rosan lock ring exhaust studs have been superseded by stainless steel studs on the Gold Standard cylinder configuration. If the existing cylinders are fitted with Rosan lock ring studs, they may be replaced at overhaul with the appropriate size Rosan studs. Do not replace stainless steel studs with Rosan lock ring studs.

The step type captive lock ring studs have a larger lock ring than the size-on-size type. The size-on-size captive lock ring studs utilize a small external diameter lock ring for applications where edge distance is a factor. The lock ring is so small in diameter that the use of a typical Rosan “SM” or “BT” series-milling tool is impractical and could cause unwanted removal of cylinder head material in the lock ring area.

C-6.1. Stud Removal

NOTE: For Rosan Size-on-Size Stud Removal, refer to instructions in Section C-6.1.1. To remove Rosan Step-Type Stud Removal, refer to instructions in Section C-6.1.2.

For standard stud removal:

1. Place a stud extractor tool on the stud to be removed and turn the tool slowly to avoid heating the casting.
2. To remove a stud which cannot be removed with a standard stud extractor tool, drill a hole matching the diameter of a splined stud extractor tool through the center of the stud. Insert the splined stud extractor through the drilled center of the stud and unscrew the stud.
3. Examine the course thread end of the damaged stud before discarding it to determine the correct stud size for oversize replacement stud.

C-6.1.1. Size-on-Size Rosan[®] Stud Removal

To prevent damage to the engine cylinder, take precautions when removing a Size-on-Size Rosan stud.

1. Carefully cut the damaged stud flush with the cylinder head. Do not come in contact with or mark the cylinder head.
2. Score the remaining portion of the stud with a center punch.
3. Locate the proper size primary removal drill directly over the center of the stud and drill to the specified depth. The primary removal drill size and specified depths are listed in Table C-2.



- Center the secondary removal drill over the small hole and drill to the depth specified in Table C-2. This method should cut the engagement between the stud serrations and the internal serrations of the lock ring.

Table C-2. Rosan® Stud Primary & Secondary Bore Specifications

Cylinder Exhaust Port Stud		Primary Removal Drill		Secondary Removal Drill	
Basic Stud Number		Diameter	Minimum Depth	Diameter	(+0.015) Depth
(0.164 dia.)	SFC164	1/16(0.062)	0.250	3/16(0.188)	0.080
(0.190 dia.)	SFC190	1/16(0.062)	0.250	7/32(0.219)	0.090
(0.250 dia.)	SFC250	3/32(0.093)	0.250	19/64(0.296)	0.105
(0.312 dia.)	SFC312	1/8(0.125)	0.312	R(0.339)	0.120
(0.375 dia.)	SFC375	1/8(0.125)	0.375	13/32(0.406)	0.120

- The remaining lock ring will have a very thin wall. Carefully use a sharp punch to break away the remaining portion from the cylinder head.
- Drive an “Ezy-Out®” bolt extraction tool into the small hole in the stud and apply removal torque.
- Remove the stud and clean the hole.

C-6.1.2. Step-Type Rosan® Stud Removal

There are two methods for removing step-type Rosan® studs. Each of these methods is described below. The first uses a special tool; the second provides machining instructions to cut the stud, drill a pilot hole and remove the stud with an bolt extractor.

C-6.1.2.1. Step-Type Rosan® Stud Removal Method 1

- Use the Rosan® Stud Remover (Figure C-6 and Figure C-7) to mill the lock ring to the appropriate depth.
- Apply removal torque to remove the stud.
- Lift out the remaining portions of the lock ring.
- Carefully use a sharp punch to break away the remaining portion from the cylinder head.



Figure C-6. Rosan® Stud Removal Tool

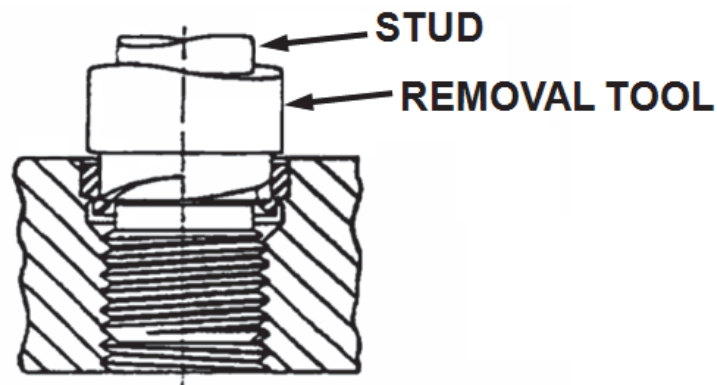

Figure C-7. Rosan® Stud Removal Tool Installed on Stud

C-6.1.2.2. Step-Type Rosan® Stud Removal Method 2

1. Follow the procedure in Section C-6.1.1, “Size-on-Size Rosan® Stud Removal.”
2. Select the appropriate removal drill sizes with regard to the stud end dimension.

NOTE: Example: To remove a step-type stud with a 0.250-inch diameter nut end and a 0.312- inch diameter stud end, use the appropriate removal drill for a 0.312-inch “size-on-size” stud.

C-6.2. Stud Installation

Standard studs may be replaced using the instructions in this section. For “Rosan® Stud Installation”, refer to instructions in Section C-6.2.1.

- Standard studs have no marking. Refer to the table below to determine the proper stud size required or to identify oversize studs.









Example Part Number	Oversize	Identification	Identification Color Code
XXXXXX	Standard	 	None
XXXXXXP003	0.003	 	Red
XXXXXXP007	0.007	 	Blue
XXXXXXP012	0.012	 	Green

Figure C-8. Stud Sizes

- Clean the casting tapped hole with solvent and blow dry any debris or liquid out of the hole using compressed air.
- Examine the thread. If it is not torn, obtain the next larger oversize stud. If the old stud was of the maximum oversize or if the thread is damaged, tap the hole and insert a heli-coil insert according to instructions in Section C-5.2.

WARNING

Heli-coils can only be installed where authorized.

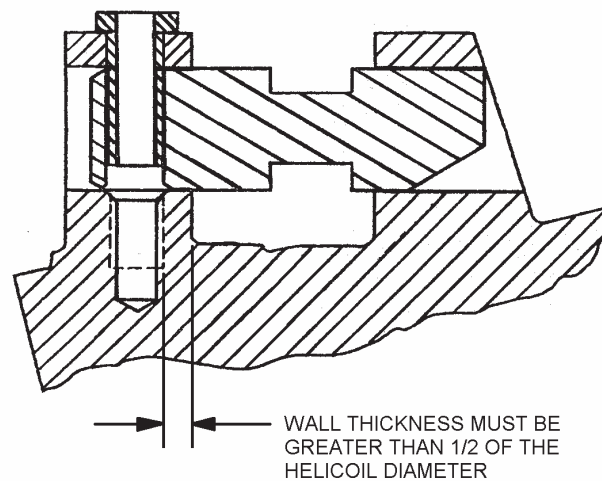

Figure C-9. Minimum Material Thickness for Helical Coil insertion



Maintenance Standards

4. A heli-coil insert can be used on a cylinder rocker shaft retaining stud provided that a minimum wall thickness of more than half of the heli-coil diameter remains after tapping for the heli-coil insert. Refer to Figure C-9.
5. If the hole is blind or if the hole goes through to a cavity subject to leakage, coat the new stud's course thread with High Strength Adhesive (Part No. 646941).
6. Drive the new stud with a tee handle stud driver. Turn it slowly and compare the torque values listed in Appendix B.
7. Drive the stud in until it reaches the desired length specified stud height in the primary ICA (Section 1-1.1).

C-6.2.1. Rosan® Stud Installation

Any type of Rosan® stud (size-on-size type or step type) may be installed using the appropriate wrench. Install the stud to the dimensions specified in Figure C-10.

CAUTION: Location of the flange is important in preventing the lock ring drive tool from making contact with surface "A" in Figure C-10. Any impact or pressure on surface A may damage the threads in the cylinder head resulting in a loose fit.

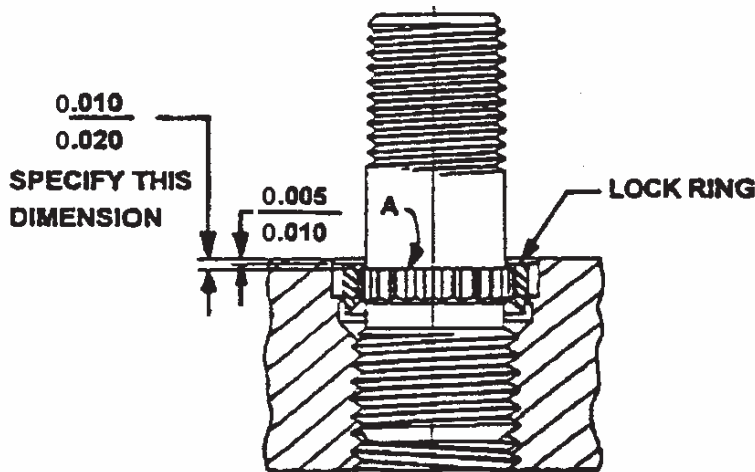

Figure C-10. Rosan® Stud Installation Dimensions



C-7. Cotter Pin Installation

Cotter pins are not reusable. Replace used cotter pins with the specified new cotter pins made of corrosion-resistant steel.

1. Install the nut on the bolt.
2. Torque the nut where the cotter pin is to be inserted to the lowest torque setting for the fastener specified in Appendix B.
3. If the slots in the nut do not align with drilled hole in the bolt, gradually increase the torque until the slot and hole align. Do not exceed the upper limit of the fastener torque specification. Change the nut if necessary.
4. Insert the cotter pin through a hole with the head seated firmly in the slot of the nut.
5. Spread the exposed ends of the cotter pin. Bend the ends over the flat on the nut and the end of the bolt.

CAUTION: Do not use side-cutting type pliers to bend back the cotter pin ends. These pliers cause nicks which can weaken the cotter pin to the extent that it can become detached.

6. Seat the ends firmly against the bolt and nut (Figure C-11).

WARNING

Wear eye protection when cutting cotter pin to avoid injury from flying debris.

7. Trim the protruding ends as necessary.
8. All cotter pins must fit snugly in holes drilled in specific hardware. On castellated nuts, unless otherwise specified, the cotter pin head must fit into a recess of the nut with the other end bent such that one leg is back over the stud and the other is down flat against the nut as shown in Figure C-11.

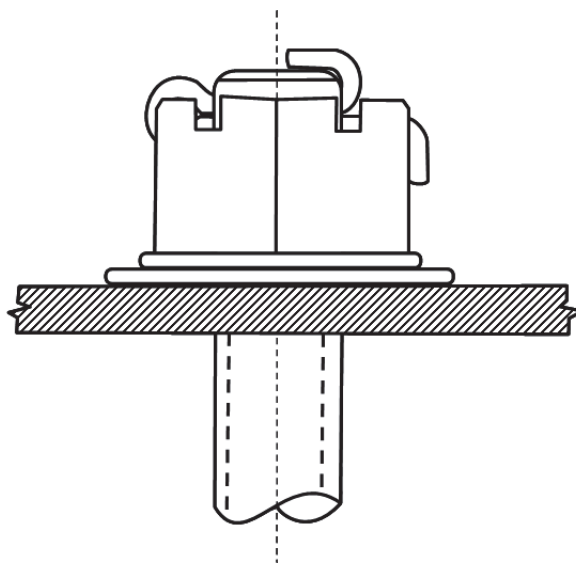

Figure C-11. Cotter Pin Installation



C-8. Fuel System Service

CAUTION: Fuel system contamination may lead to component damage, erratic engine operation, loss of power, or engine shutdown. Flush new fuel system parts, hoses and test equipment prior to connection to the system.

Fuel system service includes any inspection, service or repair action which requires opening fuel system connections, including engine operational checks. Avoid introducing contaminants into the fuel system:

- Exercise caution when installing fuel injection system parts.
- Clean surrounding component surfaces and fittings before removing parts or disconnecting hoses or fittings.
- Cap or plug open fuel system hoses or fittings immediately upon disconnection. Caps and plugs should remain in place until the time of reassembly.
- Use only clean tools and test equipment
- Purge fuel system components, regardless of source, at the time of installation.

C-8.1. Fuel System Purge

1. Remove the cap from the fuel inlet fitting of the fuel system component (hose, pump, manifold valve, fuel control unit, in-line filter, or test equipment).
2. Connect the aircraft or engine fuel supply to the inlet fitting and tighten to prevent leakage.

CAUTION: The receptacle used to collect the fuel sample must be free of dust, debris, water, oil, or other particulates or contaminants for valid inspection results.

3. Connect a clean section of fuel hose to the component fuel outlet(s) and direct the end of the hose into a suitable, clean, one-half gallon (two liter) fuel receptacle.
4. Turn the fuel selector valve ON.
5. Turn the aircraft boost pump ON.
6. Allow at least one quart (.95L) of fuel to flow through the component into a clean fuel receptacle. If the component features a mixture or throttle control lever, cycle the lever through the full range of operation several times while fuel is flowing through the component.
7. Turn the aircraft boost pump OFF and inspect the filter for contamination.
8. Allow at least two minutes for particulates to settle in the container. Visually inspect the fuel in the container for contamination. If contamination is found, isolate and correct the source of the contamination before proceeding with component installation.
9. Repeat steps 4 through 8 until no contamination is found in the receptacle.
10. Proceed with component installation according to instructions in the primary ICA.



C-9. Gasket Maker® Application

Gasket Maker is an easily workable tacky gel which can be applied onto one side of a flange surface from a tube and evenly spread.

WARNING

Apply Gasket Maker only as directed. The improper use of sealants may cause engine malfunction or failure. Do not apply any form of sealant to the crankcase cylinder deck, chamfer, cylinder mounting flange, cylinder base O-ring, main bearing bosses, or cylinder fastener threads. The use of RTV, silicone, Gasket Maker or any other sealant on the areas listed above during engine assembly will cause a loss of cylinder deck stud or through-bolt torque. Subsequent loss of cylinder attachment load, loss of main bearing crush and/or fretting of the crankcase parting surfaces will occur. The result will be cylinder separation, main bearing movement, oil starvation and catastrophic engine failure. USE ONLY CLEAN 50 WEIGHT AVIATION ENGINE OIL ON SURFACES LISTED.

1. Verify the surface where the sealant will be applied is clean and free of nicks, burrs, oil, and grit.
2. For the engine nose seal, apply Part No. 653692 General Purpose Primer to prepare the sealant surface before applying Gasket Maker at the engine nose seal area.
3. Apply and spread a thin, translucent coat of Part No. 646942 Gasket Maker (not to exceed 0.010 inches in thickness) to the surface directly from the tube. For small parts, use a polyester urethane sponge or a short nap roller saturated with Gasket Maker to apply the sealant to the part.
4. Once Gasket Maker has been applied, evenly torque the assembly into place.
5. Wipe away excess sealant with chlorinated solvent.
6. To remove Gasket Maker from your hands, apply waterless mechanics hand soap followed by soap and water.



C-10. Gasket Installation

WARNING

Apply Gasket Maker only as directed. The improper use of sealants may cause engine malfunction or failure. Do not apply any form of sealant to the crankcase cylinder deck, chamfer, cylinder mounting flange, cylinder base O-ring, main bearing bosses, or cylinder fastener threads. The use of RTV, silicone, Gasket Maker or any other sealant on the areas listed above during engine assembly will cause a loss of cylinder deck stud or through-bolt torque. Subsequent loss of cylinder attachment load, loss of main bearing crush and/or fretting of the crankcase parting surfaces will occur. The result will be cylinder separation, main bearing movement, oil starvation and catastrophic engine failure. USE ONLY CLEAN 50 WEIGHT AVIATION ENGINE OIL ON SURFACES LISTED.

Gaskets and components must be properly positioned with the hardware torqued and safety wired, as required, during assembly to prevent oil loss.

Install only new gaskets. If the gasket material is age-sensitive (package or gasket is stamped with a date code), verify the use by date has not passed. Prior to installation, inspect each gasket for brittleness, cracks, wrinkles, damage, or deformities. Do not use a gasket with obvious defects, even if new; replace with a new manufacturer-specified gasket. Verify that gasket surfaces are clean and free of nicks, burrs, oil, and grit.

CAUTION: Do not install brittle, dirty, cracked, or wrinkled gaskets. Never reuse a gasket removed during disassembly.

1. Apply a thin coat of Part No. 642188 Gasket Sealant to both sides of the gasket unless otherwise specified.
2. Install the gasket, following the contour of the mating surface.
3. Install the assembly and evenly torque the hardware to Appendix B specifications to prevent damage to the gasket
4. Safety wire the hardware where indicated.

C-11. Hose and Tubing Installation

Hoses and tubing to fuel, induction, lubrication, and turbocharger system fittings must be properly installed.

WARNING

Failure to properly support component fittings can result in fitting and/or component damage and a resulting loss of system pressure or fluid.

1. Where multiple fittings are used, each fitting must be isolated from adjacent fittings for proper torque application. Use a wrench on both mating connections to avoid applying excessive torque to the fittings. Securely tighten fittings and torque to the specified value in Appendix B. Torque the hose or tubing end fitting while maintaining sufficient force on adjacent fittings to prevent twisting and shear loads.

CAUTION: Do not exceed specified torque values

2. Support the last fitting in the assembly on components that contain multiple fittings coupled in one location. **DO NOT** over-torque fittings.

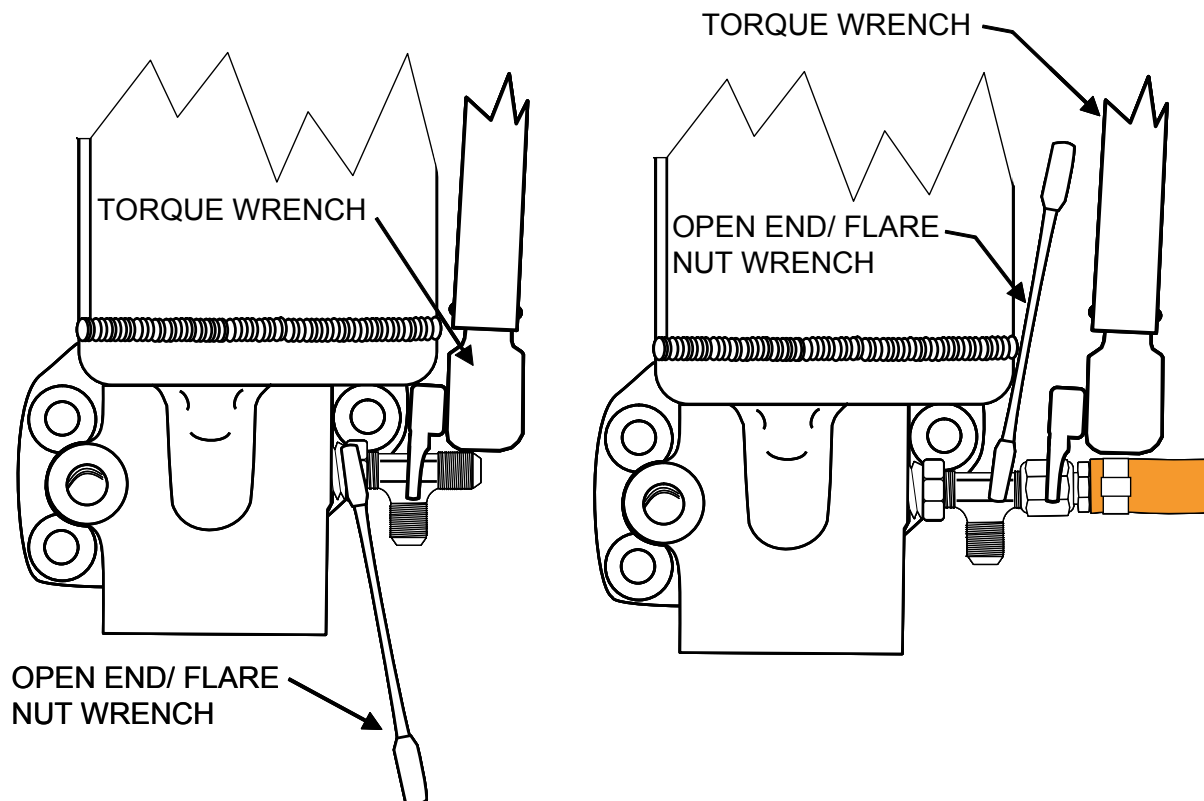

Figure C-12. Installing Hoses and Fittings



C-12. Harness Routing

1. Inspect all proposed harness routes. Consider normal movement and relative motion of the various engine or aircraft parts that will be attached to the harness.
2. Do not route harnesses near belts or pulleys without the use of belt guards; belt failure may damage the wiring harness.
3. Do not secure wiring harnesses to fuel lines.
4. Use cushion clamps, with stand-off spacers, where necessary to secure the harness to existing baffle supports and brackets where practical.
5. Secure harnesses to minimize the possibility of chafing, vibration, and excessive heat exposure.
6. The largest allowable unsecured segment of wiring harnesses is eight (8) inches (20.32 cm).
7. Route the wiring harnesses through baffles where necessary. All baffle penetrations by a harness must be lined with a suitable grommet to prevent damage.



Continental Motors
www.continentalmotors.aero