

August 2022 #7



**Dues Due January 1!**

12 month annual dues are \$20  
1 Jan 2022 through 31 Dec 2022  
Payable to Stuart Rauh  
1717 East Thornton  
Des Moines, IA 50320  
or online:  
<http://135.eachapter.org>



**THE MEETING IS A WEEK EARLIER THIS MONTH!!**  
(Dave and Stuart are you reading this?)

## President's Ramblings

Greetings fellow Chapter 135 members - Generally, I find myself writing the August ramblings or at least working on it while I'm at AirVenture. Since the energy of there seems to just carry over onto the paper. I can't imagine why? LOL - This year due to our newsletter putter together-er (is that a word) heading to Orkney in Scotland for a vacation has prompted me to compile my aviating thoughts before heading to the big festival. Yes, I think I can refer to Air Venture as a festival since I've spent countless hours attending as well as volunteering over the years. Still its for a great cause and volunteering it's like a mini family reunion every year except you actually look forward to seeing your fellow volunteers vs the typical family reunion which can be strange when auntie Alice brings her lime Jell-O and its not exactly what she remember she prepared.....LOL you know how it can go....

This year's poker run remained status quo with seven aircraft participating while 16 showing up for the cookout. See the poker run insert recap in this newsletter for details.

Anyway, we will have enough warm bodies to flip cakes at AirVenture on the 23rd of July between chapter 135 and 675 plus a favor called in. Our labor will fund both chapters. Of course, there will be pictures, heck might even see us in the next edition of Sport Aviation.

A couple years ago we had a program on 3-D printing by Jeff Beckley. Jeff played around with this and shared his experience with making various items on his printer. Now you're thinking where is he going with this....It amazes how far 3-D printing

**General Meeting Most Likely Saturday, Aug. 06, 2022**  
**5:00 Stewarts Field**  
**Roger and Janet are supplying pork loin, baked potatoes and corn. Bring a side dish. Go to Fly Iowa in Iowa Falls in the morning and end up at Stewart's Field for dinner.**

has evolved and what you can accomplish with 3-D printing when it comes to building an airplane.

On the Rans S-21 that I'm building the top skin of each wing needs a slight curve on the leading edge to fit snugly and mate up with the leading edge on the forward spar. Here's the drawing you get in the instructions from the company as this is the builders format to do this task in making this jig. One of these search and discovery things as one scratches the head thinking where do I find the material. Originally, I

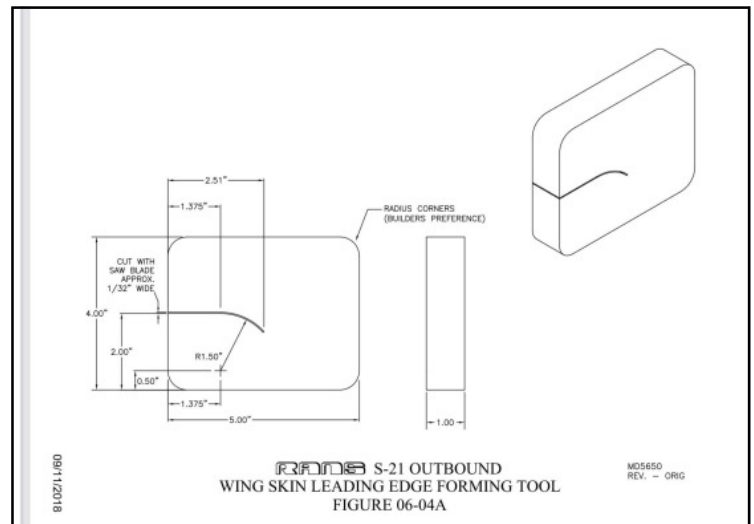

pondered using a piece of hardwood but didn't feel that was the correct material or it mar the skin's surface. The next picture is the printed drawing completed. It's very cool. As a builder, I reached out to a couple of good friends asking for any assistance on finding the material to make the forming/jig device. One of the two I reached out to came back stating he has a friend that does 3-D printing and loves a good challenge. Now you see the results of friends. They always have another perspective or know someone who might be able to get it done for ya. Like the founder of EAA Paul Poberezny "Airplanes bring us together - Friendship keeps us together" is so true.

The results of the 3-D printed forming jig worked exactly as expected. It gave me a nice slight curve on the top skin that fit neatly and snug onto the leading edge. Next is to begin match drilling the entire leading edge some eighty holes which will be deburred and countersink then flush (pop) riveted. Rans has a few places they use flush rivets but mostly they use pop rivets or pull type rivets. I'm enjoying building and you are always welcome to stop by Nashfield and check on my progress - coffee is on.



**We generally gather in August at Roger and Janet Stewarts for sweet corn and swapping lies, (I meant sharing our adventures....LOL). The sweet corn this season is purported to be ready around the first weekend in August, which is now our meeting date but I'll let ya know if this changes.**

I would like to say thank you to Marianne Olson who is our official newsletter putter together-for all you do for us. I hope you enjoy your trip to Scotland where they drink whisky not whiskey. Take lots of photos cause you know me I'm going to ask "this would be a great program to present to your fellow chapter members over the winter.

Till next time blue skies and tailwinds

AJ

## JULY MEETING

July's meeting was held on Sunday, July 10, 2022 in Dave Schuler's hanger. Seventeen people attended.

There was no board meeting. Poker run hands were played after a cookout and potluck meal.

Seven poker hands were played. The winning hand for a \$20.00 cash prize was held by Bill Ogier and his daughters, with a hand of two pair; queens and 10s.

The second best hand for a \$10.00 cash prize was held by Paul Reinke with two pair, 8s and 9s.

submitted by Marc Broer,



**FREE  
ADMISSION!**

# Iowa Falls Municipal Airport

16041 US 65 • Iowa Falls



# FLY IOWA



## Saturday, August 6th

Rain Date Sunday, August 7

**7:00 a.m.**

- Fly-in/Drive-In Breakfast  
Sponsored by Hubbard Fire Department

**11:00 a.m.**

- Opening Ceremony: Des Moines Skydivers

### Fly Iowa Performer Line Up:

- Erik Edgren & "T-Clips"
- Doug Rozendaal & P-51  
"Tuskegee Airmen" CAF RISE ABOVE
- Vanguard Squadron
- Susan Dacy & "Big Red"
- Bob Richards & "Machaira" Biplane

\*Aviation Youth Rally July 30 & August 4.  
See [FlyIowa.org](http://FlyIowa.org) for details!

Sponsored by:



Keith Bowden  
Paul Hoversten

Chuck McDonald  
Jerry Welden



**FOGZ  
(Flying Old  
Geezers)  
in  
Oskaloosa  
July 13**

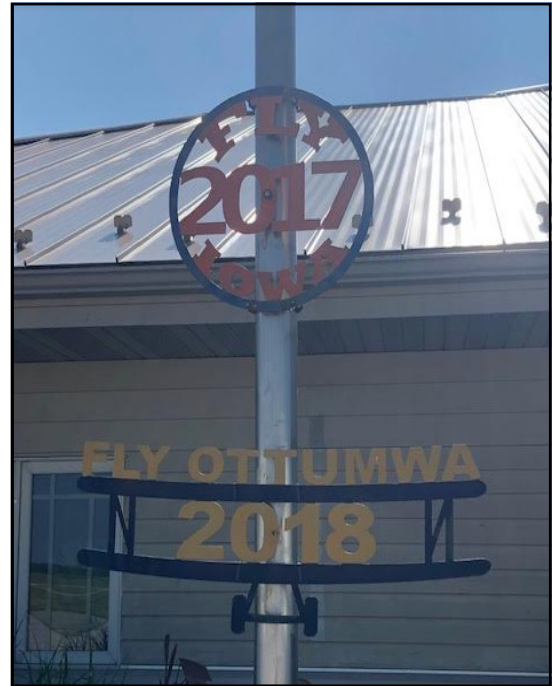

**Flight breakfast  
in Ottumwa  
July 9**





**Charles City Flight Breakfast  
July 17**



**Waverly Flight Breakfast  
July 17**



**Dave Schuler and Rodney Kubik,  
new member**

# Aviation Calendar

## SATURDAY, AUGUST 13

### Waverly Municipal Airport (C25)

Free Young Eagle flights (sign up on website)

Ages 8-17

8 a.m. – noon

EAA Chapter 227

319-240-2497 (John Dutcher)

Email: [john@balboapt.com](mailto:john@balboapt.com)

Website: [chapters.eaa.org/ea227/young-eagles](http://chapters.eaa.org/ea227/young-eagles)

### Rochester, MN International Airport (RST)

AOPA Rusty Pilot Seminar

9 a.m. – noon

Website: <https://pic.aopa.org/events/item/52/3671>

## SUNDAY, AUGUST 14

### Waukon Municipal Airport (Y01)

Fly-in breakfast

7 a.m. – noon

PIC eats free

563-568-7220 (Jim Wadsworth)

Email: [jim@jwkitchens.com](mailto:jim@jwkitchens.com)

## WEDNESDAY, AUGUST 17

### Council Bluffs Municipal Airport (CBF)

Great Plains Wing CAF Flight Cookout

Cookout: 5:30 p.m. to 7:00 p.m.

402-981-4633 (Jeff Hutcheson)

Email: [jeffhutcheson3@gmail.com](mailto:jeffhutcheson3@gmail.com)

## SUNDAY, AUGUST 14

### Waukon Municipal Airport (Y01)

Fly-in breakfast

7 a.m. – noon

PIC eats free

563-568-7220 (Jim Wadsworth)

Email: [jim@jwkitchens.com](mailto:jim@jwkitchens.com)

## WEDNESDAY, AUGUST 17

### Council Bluffs Municipal Airport (CBF)

Great Plains Wing CAF Flight Cookout

Cookout: 5:30 p.m. to 7:00 p.m.

402-981-4633 (Jeff Hutcheson)

Email: [jeffhutcheson3@gmail.com](mailto:jeffhutcheson3@gmail.com)

## SATURDAY, AUGUST 27

### Greenfield Municipal Airport (GFZ)

Fly-In

7:30 a.m. – 11 a.m.

Hall of Fame Induction (following breakfast)

641-343-7184 (Greg Schildberg)

Email: [aviation@iowatelecom.net](mailto:aviation@iowatelecom.net)

Website: [www.flyingmuseum.com/](http://www.flyingmuseum.com/)

## SUNDAY, AUGUST 28

### Iowa City Municipal Airport (IOW)

Fly-In Breakfast

Pilot in command eats free

7 a.m. - noon

319-331-7044 (Jim McCarragher)

Email: [jamesm@meardonlaw.com](mailto:jamesm@meardonlaw.com)

Do you need a specialty tool and don't have it or it's too expensive for a one time use - check out Chapter 135 TOOL CRIB.

Establishing a tool crib for those that are building or need a special tool for a specific job or project.

If you have a tool you're not using and wish to share with fellow members just submit a photo so we can list it on our web page for the members to view. Next the member would contact you directly or through the chapter web page, borrow and return when complete. Current items available to members only:

- Flatbed trailer 20 to 24 feet in length
- Engine Hoist this is the crane style lift
- Pneumatic squeezer
- Set of scales are available to members & non members to rent.

EAA Chapter 135 is establishing a Tool Crib (network) to all members in good standing, which means you are in good standing with your Chapter 135 membership. If you are not, please go to the website and submit your dues to EAA Chapter 135. Once your dues are paid for the year, then you will be able to check-out items from the Tool Crib. Also, forms are available to track the tool loaned out so we can remember who has it.

## Scales Rental Info

All scale rentals require check for \$200.00 deposit. This will be returned, uncashed, upon timely return of the scale.

Rentals are for three days. This may be extended for three additional days at no charge if there are no other conflicting requests for their use, with notification by phone. Otherwise, a late fee of \$100.00 per day applies.

Chapter 135 (must be a member 3 months prior to rental date): . . . \$25.00/3days

National EAA member but not Chapter 135 member . . . . . \$75.00/3days

A&P or FBO rate . . . . \$125.00/3days

Copy of rental agreement available by email by contacting Stuart Rauh at [stuart@rauhnet.com](mailto:stuart@rauhnet.com)

## Chapter 135 Officers 2022

President: Al Hummel

Vice President: Dave Schuler

Treasurer: Stuart Rauh..... [stuart@rauhnet.com](mailto:stuart@rauhnet.com)

Secretary: Marc Broer

Newsletter Coordinator: Marc Broer

Young Eagles Coordinators: Alan Core & Adam Obrecht

### Board:

Ralph Briggs      Mike Graber      Paul Reinke      Jacob Greenfield

Brant Hollensbe      Quinn Fairchild      Ryan Rosa      Roger Stewart

12 month annual dues for 2022 will be \$20  
and run 1 January 2022 through  
31 December 2022.

Name:

EAA No.:

Address:

Phone:

Email:

Our new bylaws move our fiscal year to Jan. 1, so the dues that are due June 30th will be for \$10.00,  
Then \$20.00 dues will be due Jan. 1, 2020

**LIFETIME MEMBERSHIP DUES ARE \$200.00** You must be a member of the National EAA

**Mail dues to: Stuart Rauh • 1717 East Thornton • Des Moines, IA • 50320**